

# TECHNICAL CATALOG

Aluminum Door Window And Facade System



Frame height size: 48 mm

Frame width size: 128 mm

Sash height size: 86/96.5 mm



Sash width size: 56 mm

Profile wall thickness: 1.4-2 mm

Polyamide size: 24/14.8 mm

Glass thickness: 8-40 mm

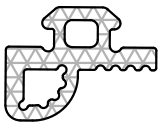
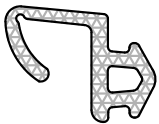
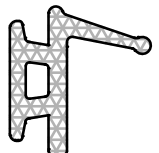
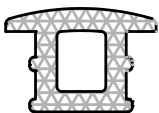
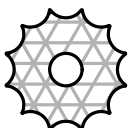
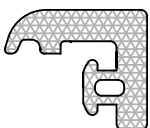
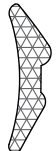
# S560 MONO RAIL

Shape	Codee	Description
	560-1011	corner adapter gasket EPDM
	560-1012	corner adapter gasket EPDM
	56300	interlock gasket EPDM
	300-176	300-176 EPDM
	300-177	300-177 EPDM
	fly screen gasket	fly screen gasket EPDM
	300-175	monorail frame gasket EPDM
	G1002	inner glazing gasket
	G1003	inner glazing gasket
	G1004	inner glazing gasket

CS59

CS68

CS68F

CS68H

CS77

CS77H

MASTERLINE8

SLIMLINE38

S560

S560 Mono

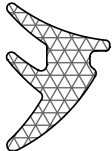
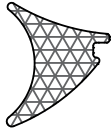
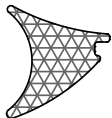
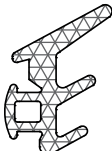
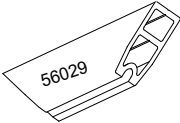
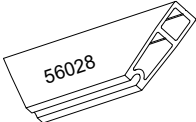
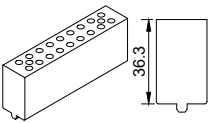
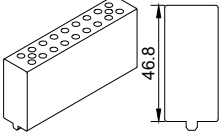
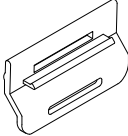
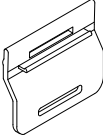
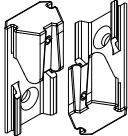
Shape	Codee	Description
	G1005	inner glazing gasket
	G1006	inner glazing gasket
	G1007	inner glazing gasket
	mo68	outer glazing gasket
	560-1006	small sash fixing profile ALUMINUM
	560-1007	big sash fixing profile ALUMINUM
	560-1020	small sash fixing -pvc PVC
	560-1021	big sash fixing -pvc PVC
	560-1008	small sash stabilization spacer POLYAMID
	560-1009	big sash stabilization spacer POLYAMID
	560-1013	Corner stile locking point STEEL

CS59

CS68

CS68F

CS68H

CS77



CS77H

MASTERLINE8

SLIMLINE38

S560

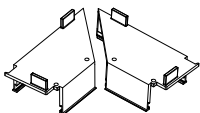
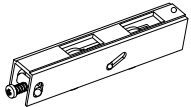
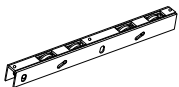
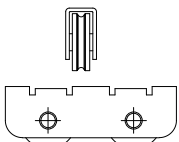
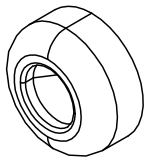
S560 Mono

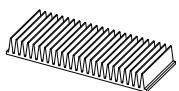
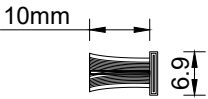
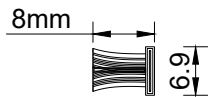
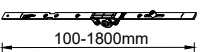
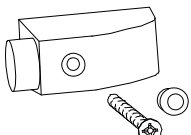
Shape	Codee	Description
	560-1014	corner adapte end cap POLYAMID
	560-1014	Aluminium double roller 130kg ALUMINIUM
	560-1015	Aluminium quad roller 260kg ALUMINIUM
	560-1016	steel double roller 300kg STEEL
	560-1010	Shock absorber for sash for lift &slide EPDM
	water reekt cover	water reekt cover PLASTIC
	560-1017	central sealing bottom EPDM
	620-69-110	brush No 10 for sliding sash
	620-69-108	central locking sealing gasket
	multi point lock	multi point lock
	560-1004	rear stoper PLASTIC

CS59

CS68

CS68F

CS68H

CS77



CS77H

MASTERLINE8

SLIMLINE38

S560

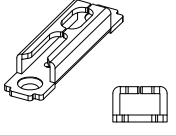
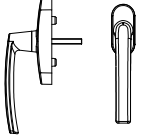
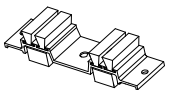
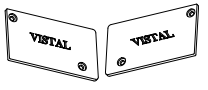
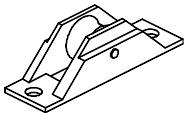
S560 Mono

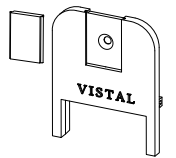
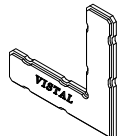
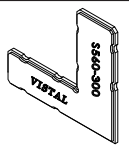
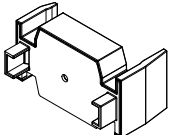
Shape	Codee	Description
	muti point lock striker	muti point lock striker STEEL
	multi point lock handle	multi point lock handle
	central sealing top	central sealing top
	3820 end caps	3820 end caps POLYAMID
	fly screen roller	fly screen roller
	PVC900	frame isolation gasket PVC
	560-1003	Top and bottom interlock POLYAMID
	560-1001	sash alignment corner POLYAMID
	560-1002	sash alignment corner POLYAMID
	560-1005	meeting stile cap POLYAMID

CS59

CS68

CS68F

CS68H

CS77

CS77H

MASTERLINE8

SLIMLINE38

S560

S560 Mono

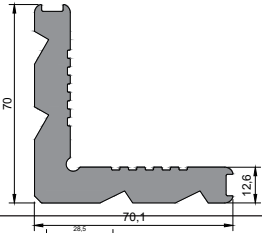
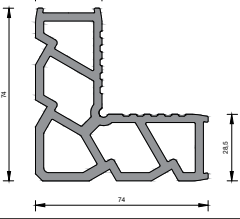
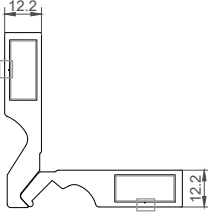
Shape	Codee	Description
	C12.6	corner cleat 4.020 kg/m
	C28.5	corner cleat 3.750 kg/m
	PC12	corner cleat (punch)

CS59

CS68

CS68F

CS68H

CS77

CS77H

MASTERLINE8

SLIMLINE38

S560

S560 Mono

CODE	WEIGHT(kg/m)	Ix cm <sup>4</sup>	Iy cm <sup>4</sup>
56017-56018	2.180	16.4	160.1
6013-76011	1.800	7.08	89.78

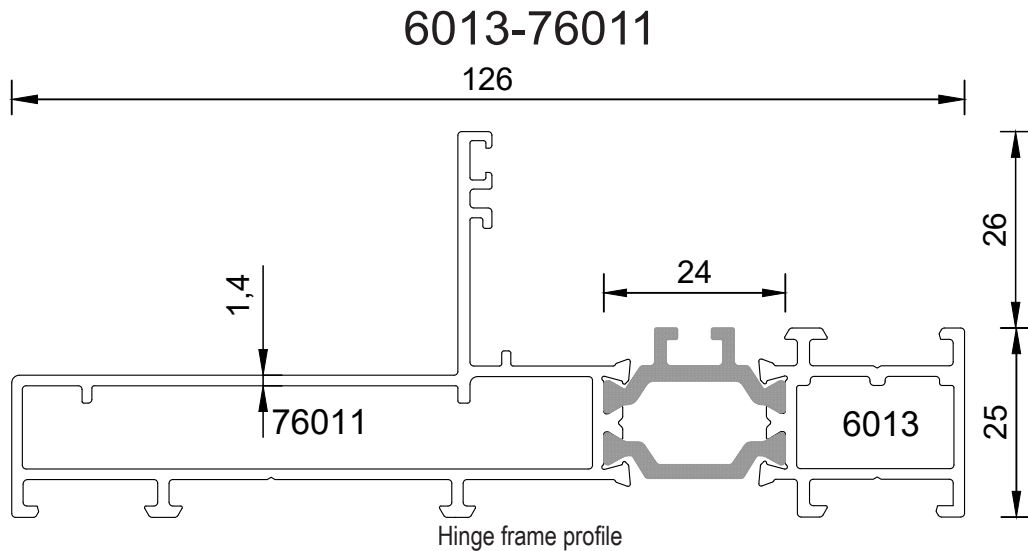
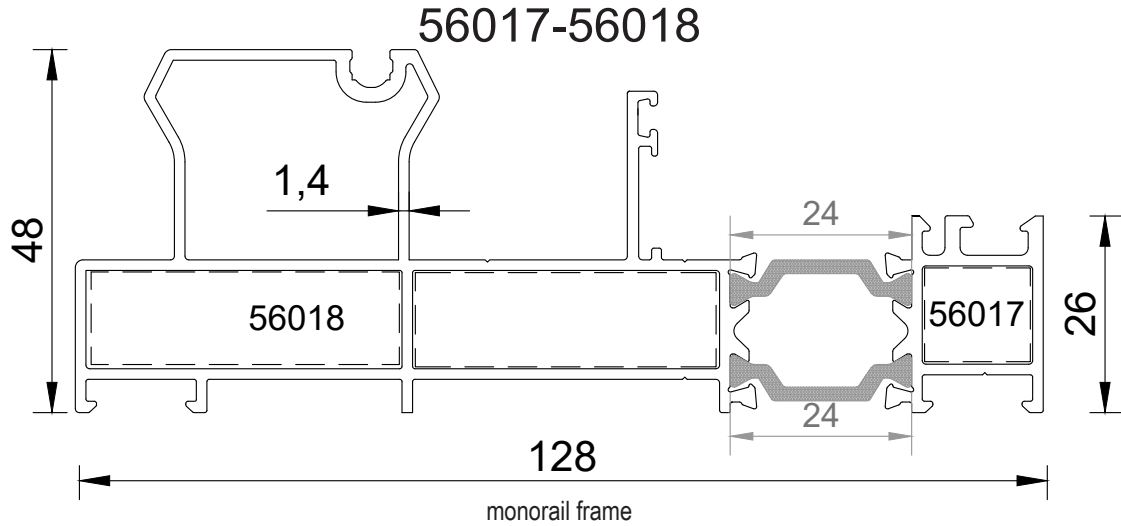

profile	corner cleat	shape	cutting size	punch corner	shape	leinght
56017-56018	C12.6 x 2		40.8 mm	PC12.2		40.2 mm
	C12.6		12.2 mm	PC12.2		40.2 mm
6013-76011	C10.6		49 mm	PC10		48.4 mm
	C10.6		19.8 mm	PC10		19.2 mm

- CS59
- CS68
- CS68F
- CS68H
- CS77
- CS77H
- MASTERLINE8
- SLIMLINE38
- S560
- S560 Mono

CODE	WEIGHT(kg/m)	Ix cm <sup>4</sup>	Iy cm <sup>4</sup>
56005-56006	2.120	38	33.9
56007-56008	1.880	27.5	28.96

- CS59
- CS68
- CS68F
- CS68H
- CS77
- CS77H
- MASTERLINE8
- SLIMLINE38
- S560
- S560 Mono

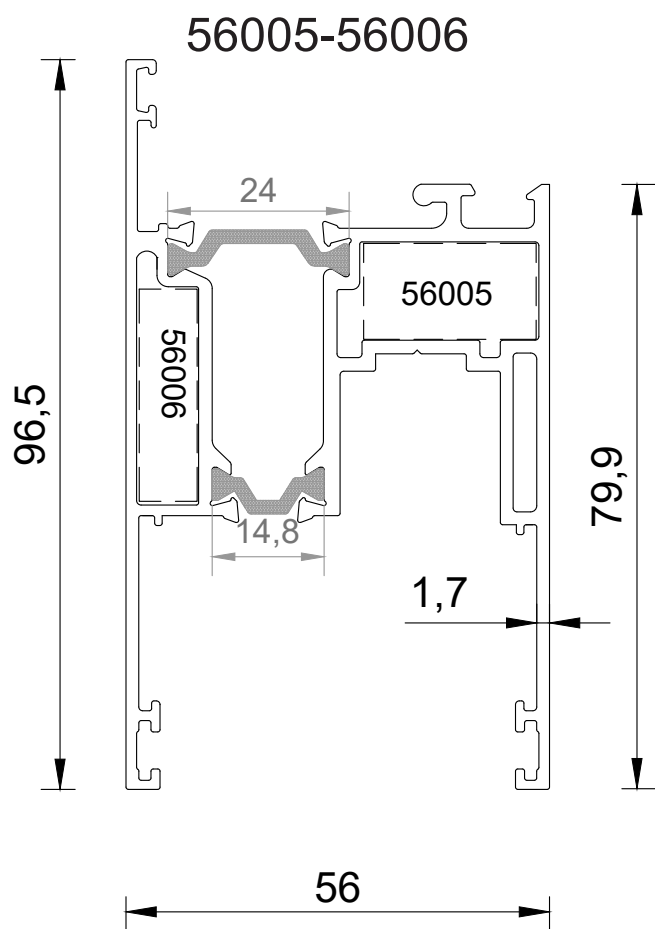

300kg-big sash profil

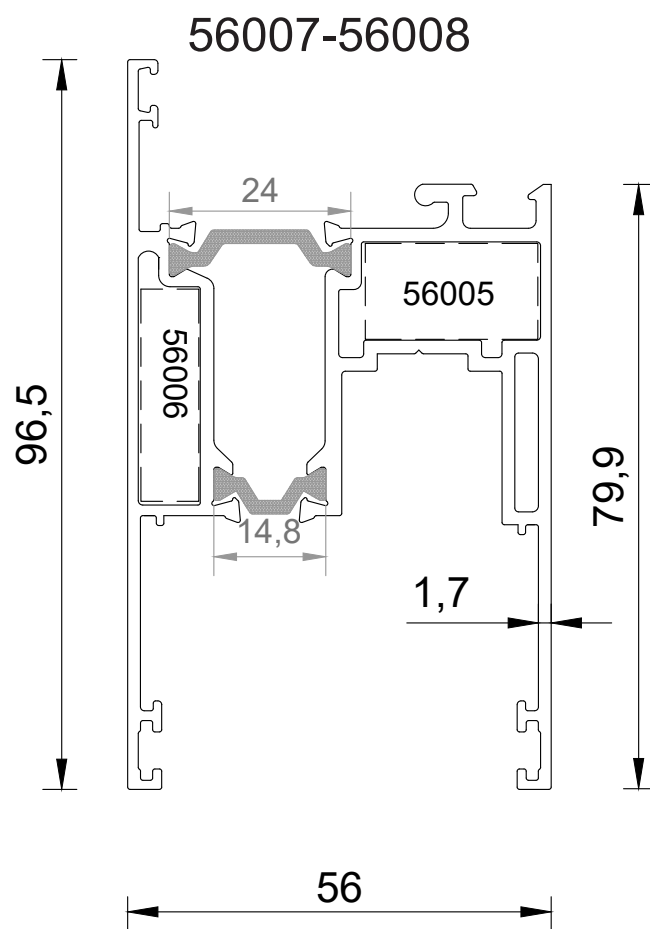

200 kg-big sash profil

profile	corner cleat	shape	cutting size
56005-56006	C28.5		6.8 mm
	C12.6		24 mm
56007-56008	C28.5		6.8 mm
	C12.6		24 mm



CODE	WEIGHT(kg/m)	Ix cm <sup>4</sup>	Iy cm <sup>4</sup>
56005-56034	2.05	32.36	30.83
56007-56035	1.770	22.11	26.12

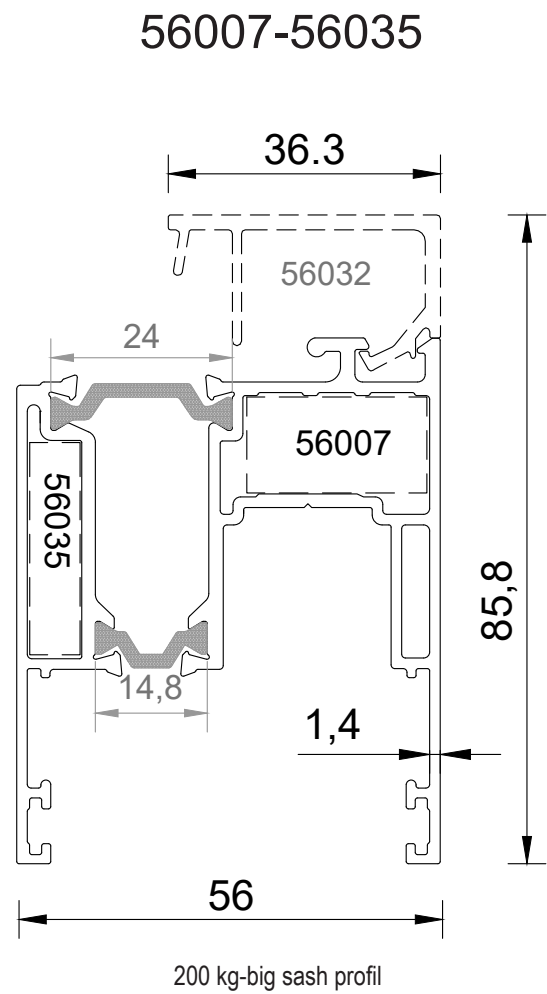
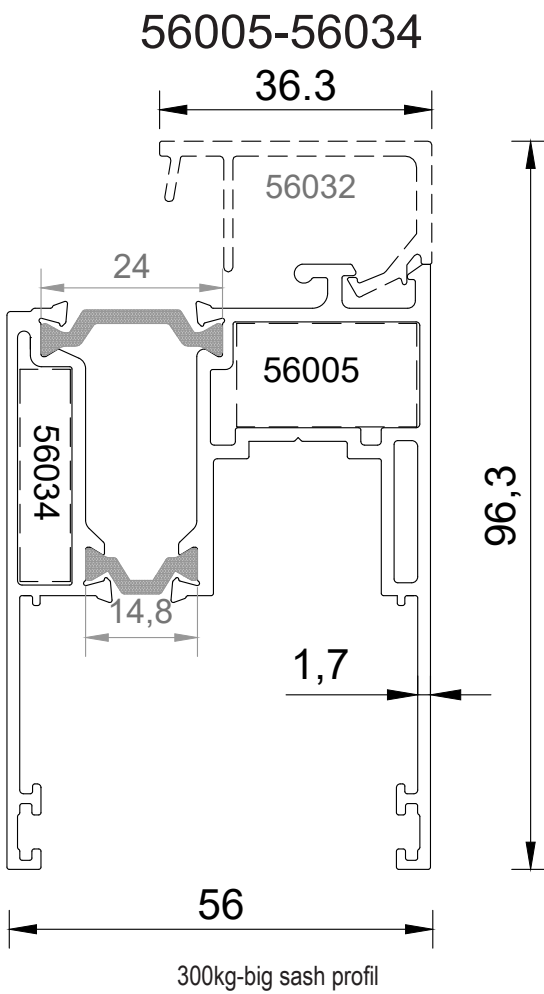

profile	corner cleat	shape	cutting size
56005-56034	C28.5		6.8 mm
	C12.6		24.3 mm
56007-56035	C28.5		6.8 mm
	C12.6		24.3 mm

CODE	WEIGHT(kg/m)	Ix cm <sup>4</sup>	Iy cm <sup>4</sup>
56021-56022	2.000	46.99	29.99
56015-56016	1.810	24.91	26.74

- CS59
- CS68
- CS68F
- CS68H
- CS77
- CS77H
- MASTERLINE8
- SLIMLINE38
- S560
- S560 Mono

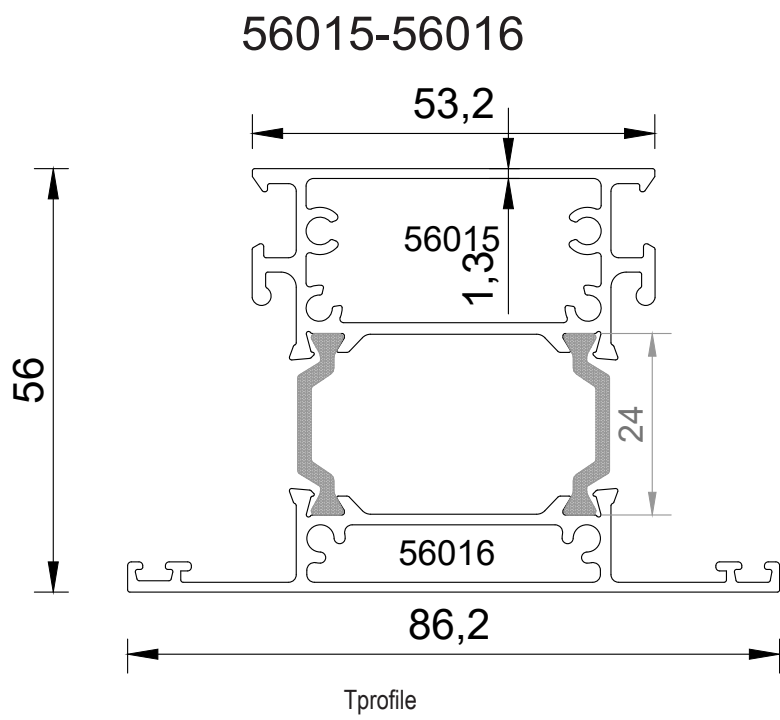
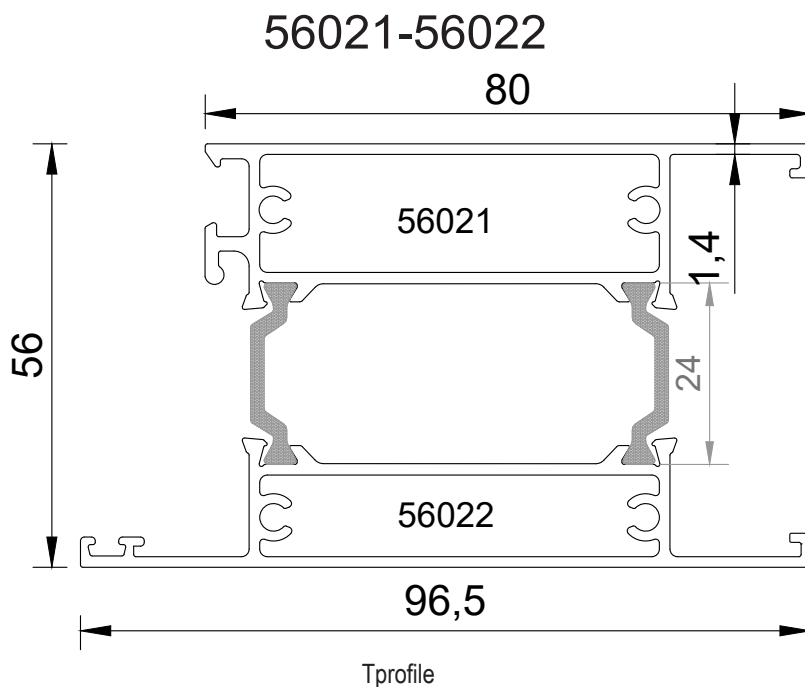

CODE	WEIGHT(kg/m)	Ix cm <sup>4</sup>	Iy cm <sup>4</sup>
56010-56011	1.440	7.8	18.16
56030-56031	2.700	24.07	6.98

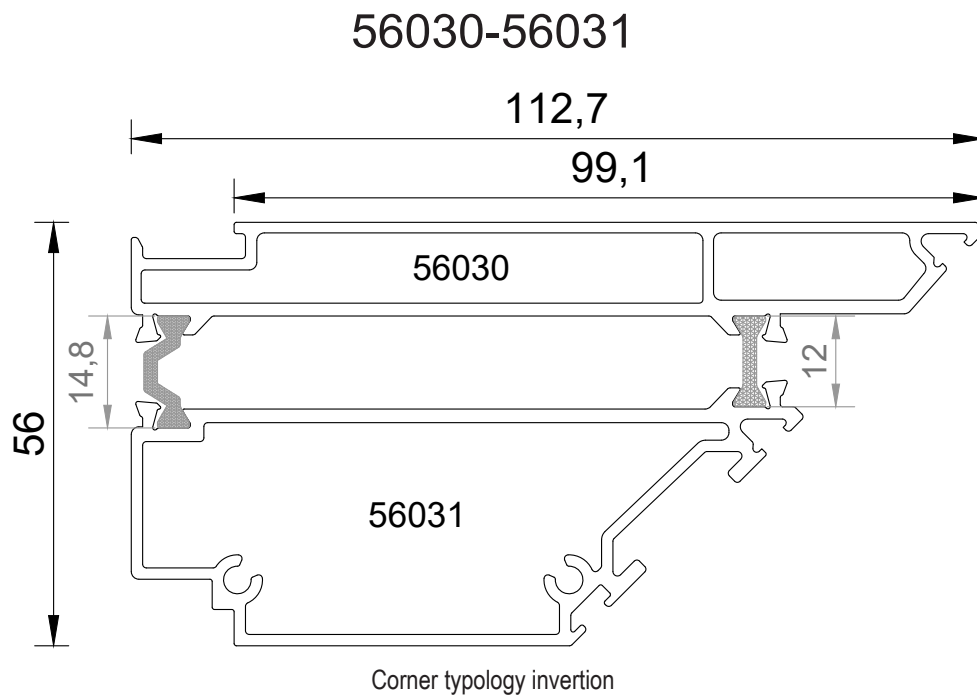
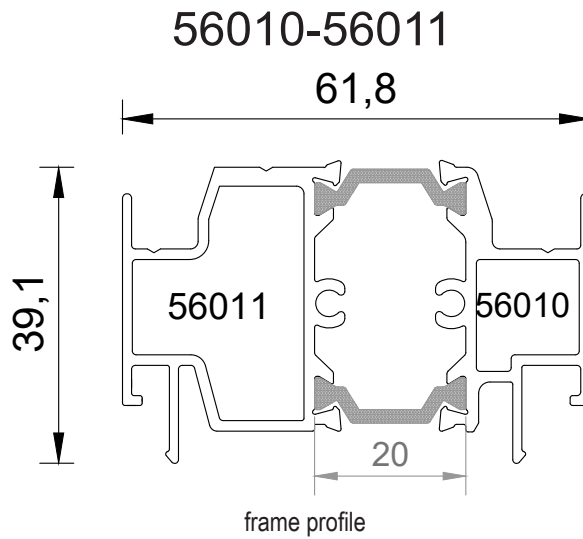

profile	corner cleat	shape	cutting size	punch corner	shape	leight
6013-38103	C10.6		19.8 mm	PC10		19.2 mm
	C10.6		49 mm	PC10		48.5 mm

- CS59
- CS68
- CS68F
- CS68H
- CS77
- CS77H
- MASTERLINE8
- SLIMLINE38
- S560
- S560 Mono

CODE	WEIGHT(kg/m)	Ix cm <sup>4</sup>	Iy cm <sup>4</sup>
56033	1.810	24.91	26.74
559	0.183	-	-
56028	1.157	-	-
56029	0.990	-	-

**56033**

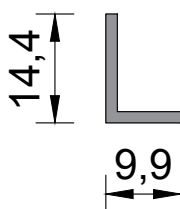

small sash fixing profile

**559**

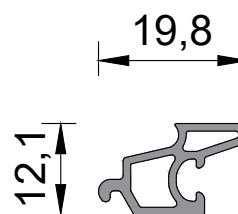

interlock hook for big sash

**56028**

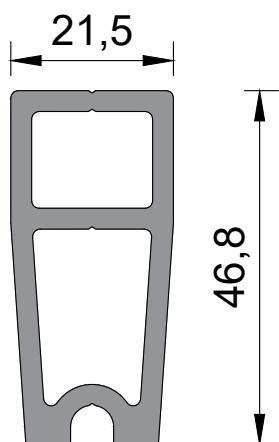

big sash fixing profile

**56029**

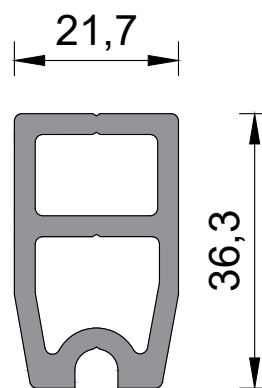

small sash fixing profile

CS59

CS68

CS68F

CS68H

CS77

CS77H

MASTERLINE8

SLIMLINE38

S560

S560 Mono

CODE	WEIGHT(kg/m)	Ix cm <sup>4</sup>	Iy cm <sup>4</sup>
56009	0.223	-	-
21449	0.424	-	-
567	0.400	-	-
21499A	0.113	-	-
21450	0.171	-	-

56009

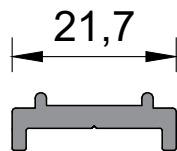

lift & sliding adapter for small sash

21449

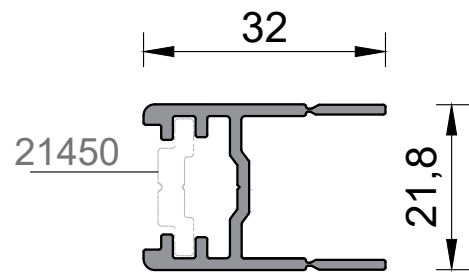

adaprer for sliding

567

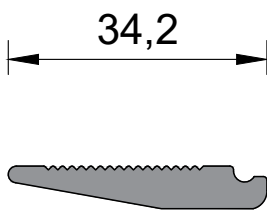

glass suport profile

21499A

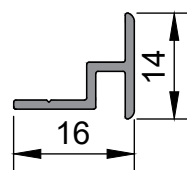

between two frame

21450

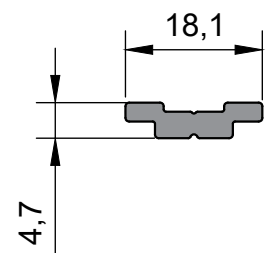

adaprer for sliding

CS59

CS68

CS68F

CS68H

CS77

CS77H

MASTERLINE8

SLIMLINE38

S560

S560 Mono

CODE	WEIGHT(kg/m)	Ix cm <sup>4</sup>	Iy cm <sup>4</sup>
3819	0.96	10.58	4.64
3820	0.770	9.59	4.64
21436	0.124	-	-
21252	0.340	-	-
21430	0.770	-	-

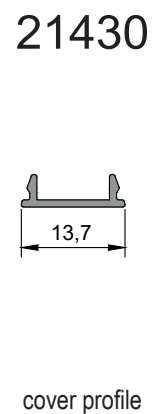
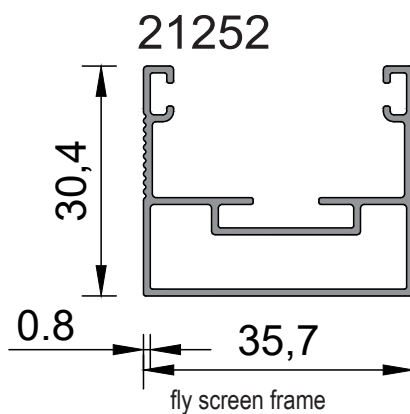
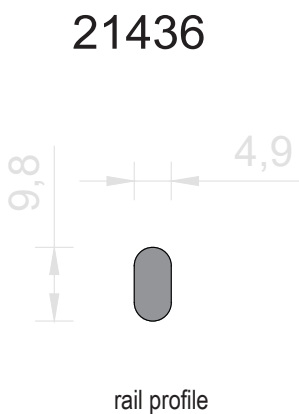
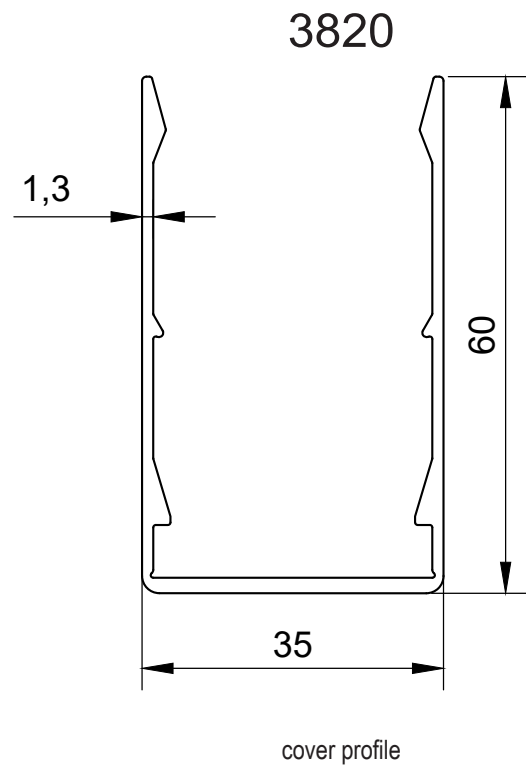
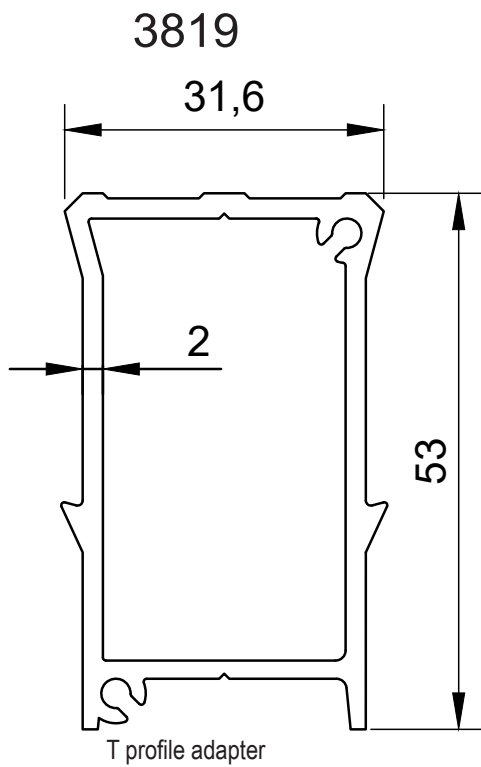

CS59

CS68

CS68F

CS68H

CS77

CS77H

MASTERLINE8

SLIMLINE38

S560

S560 Mono

CODE	WEIGHT(kg/m)	Ix cm <sup>4</sup>	Iy cm <sup>4</sup>
56020	0.450	0.76	7.92
56019	0.545	1.0	10.05
568	0.376	0.22	6.60
56013	0.352	1.06	5.83

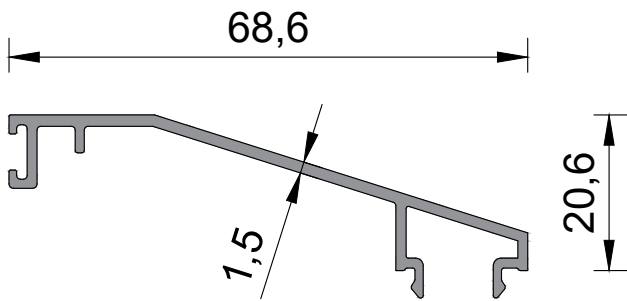
**56020**

cover profile

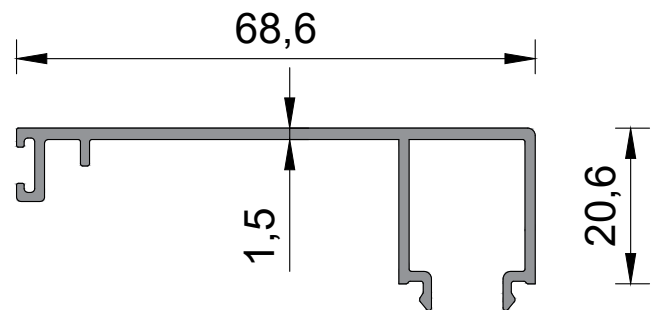
**56019**

adapter profile

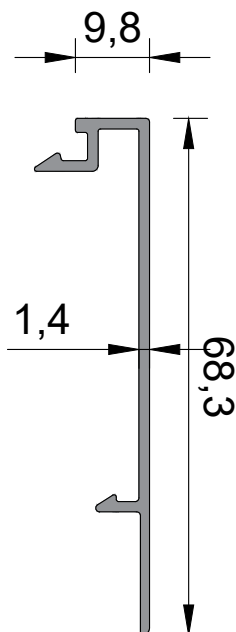
**568**

interlock profile

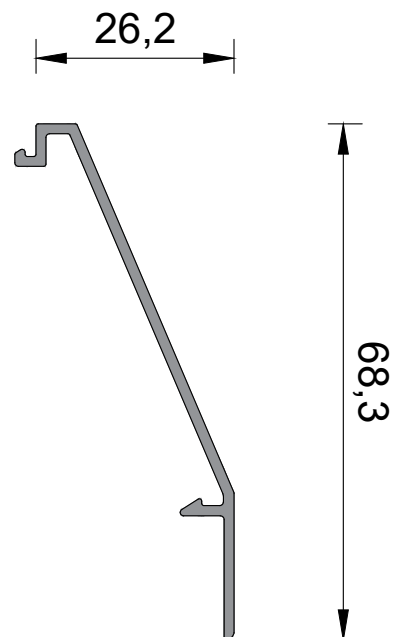
**56013**

between two frame

CS59

CS68

CS68F

CS68H

CS77

CS77H

MASTERLINE8

SLIMLINE38

S560

S560 Mono

CODE	WEIGHT(kg/m)	Ix cm <sup>4</sup>	Iy cm <sup>4</sup>
21933	0.265	-	-
21411	0.49	-	-
21503	0.477	-	-
21413	0.15	-	-
21410	0.705	-	-

21933

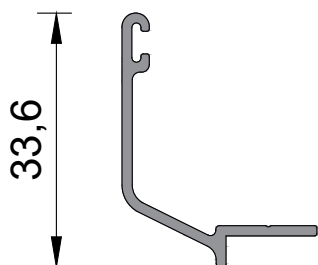

flyscreen sash rail

21411

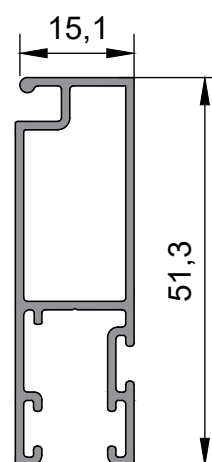

flyscreen sash profile

21503

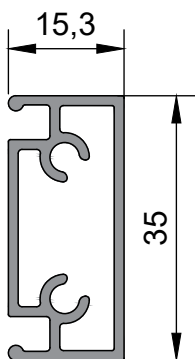

T for flyscreen sash

21410

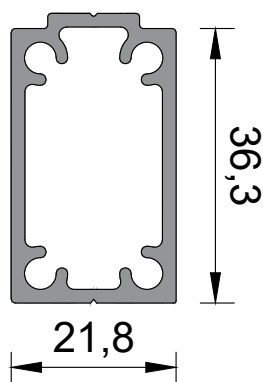

adapter profile

21413

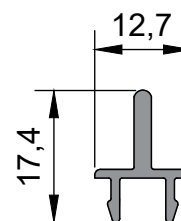

adapter profile

CS59

CS68

CS68F

CS68H

CS77

CS77H

MASTERLINE8

SLIMLINE38

S560

S560 Mono



CODE	WEIGHT(kg/m)	$I_x$ cm <sup>4</sup>	$I_y$ cm <sup>4</sup>
21251	0.370	-	-
21427	0.348	-	-
21426	0.305	-	-
21429	0.306	-	-

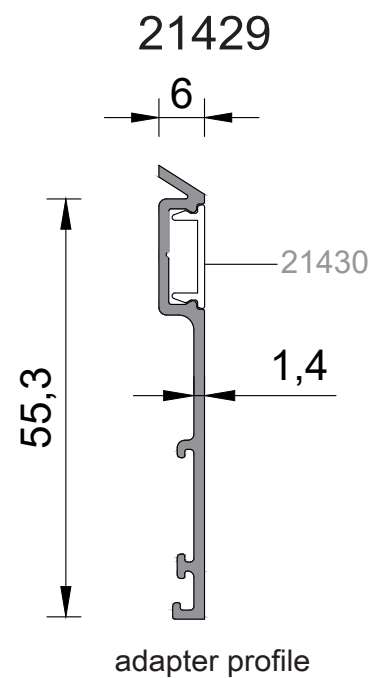
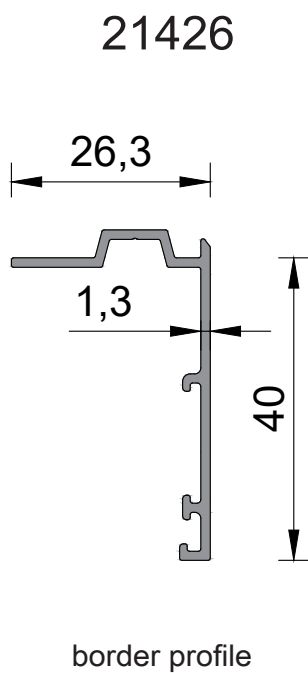
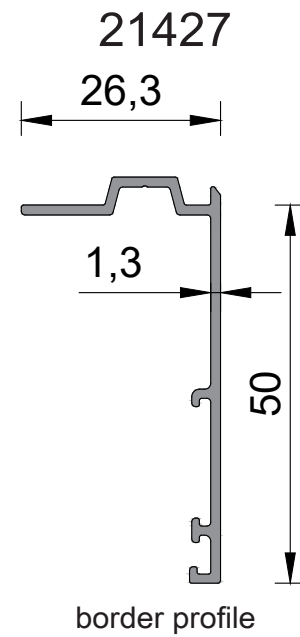
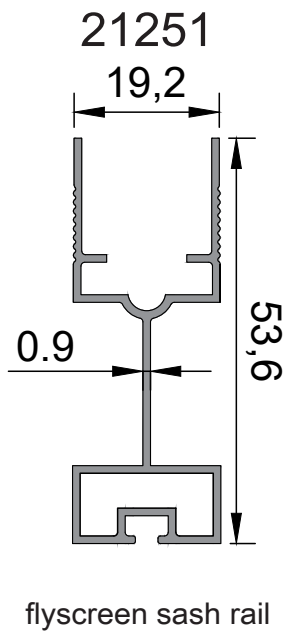

CODE	WEIGHT(kg/m)	Ix cm <sup>4</sup>	Iy cm <sup>4</sup>
21382	0.215	-	-
56024	0.263	-	-
56023	0.298	-	-
56032	0.432	-	-

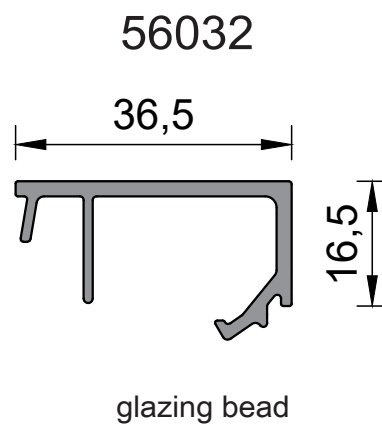
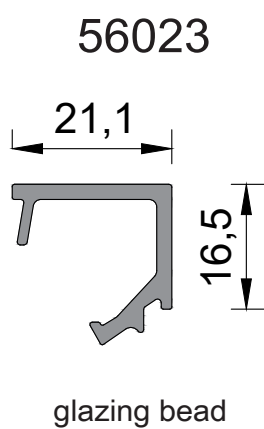
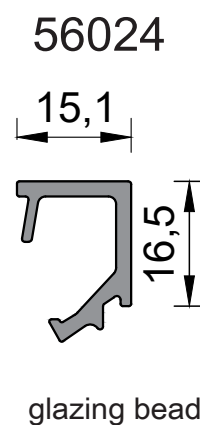
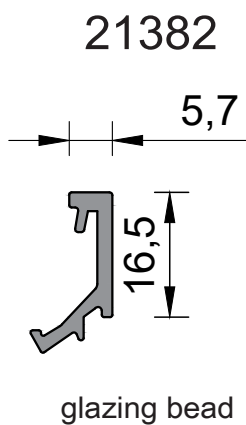

CS59

CS68

CS68F

CS68H

CS77

CS77H

MASTERLINE8

SLIMLINE38

S560

S560 Mono

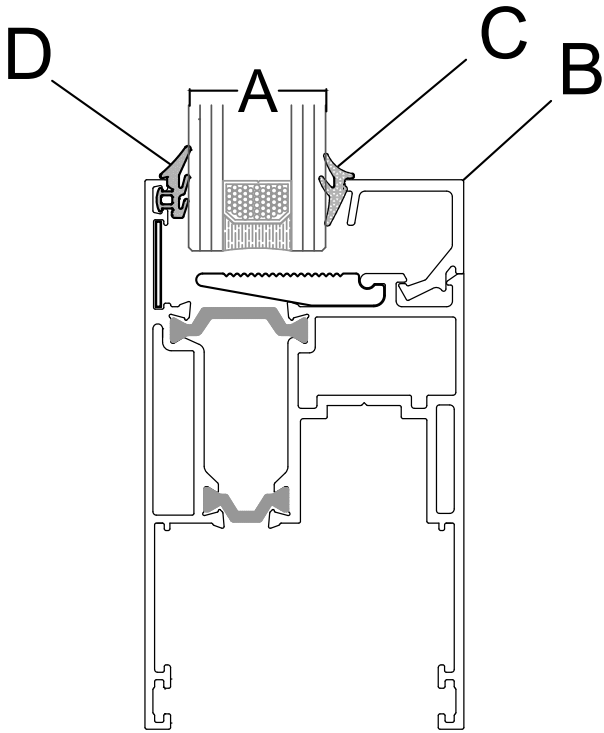

A (mm)	B	C	D
6	1006	56032	mo68
8	1004	56032	mo68
10	1002	56032	mo68
20	1007	56023	mo68
22	1005	56023	mo68
24	1003	56023	mo68
26	1007	56024	mo68
28	1005	56024	mo68
30	1003	56024	mo68
32	1002	56024	mo68
36	1007	21382	mo68
38	1005	21382	mo68
40	1003	21382	mo68

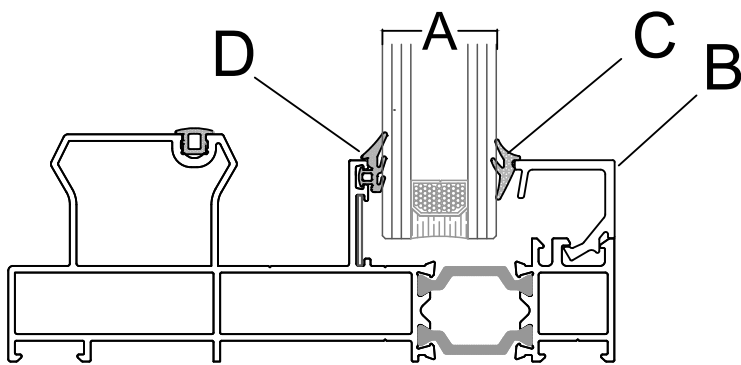

- CS59
- CS68
- CS68F
- CS68H
- CS77
- CS77H
- MASTERLINE8
- SLIMLINE38
- S560
- S560 Mono

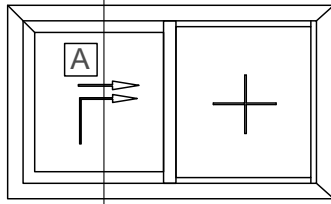

lift & slide-300 kg

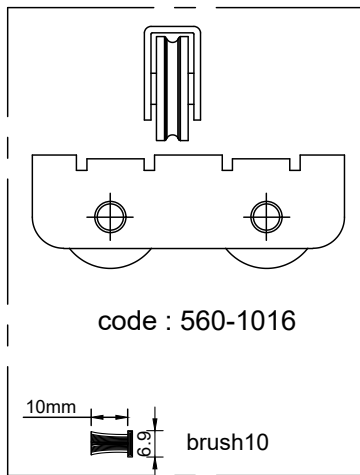

code : 560-1016

10mm

brush10



lift & slide-300 kg

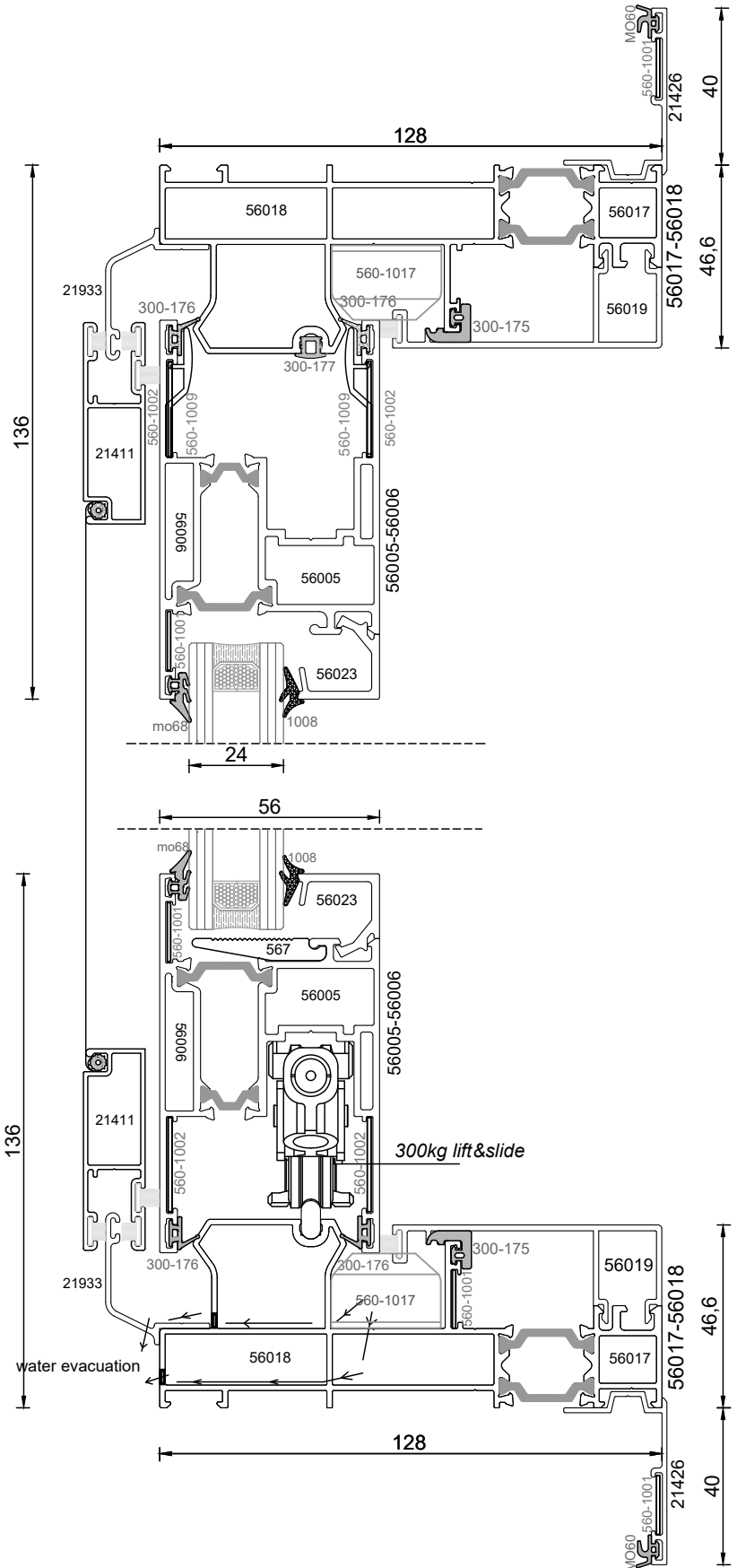

- CS55
- CS68
- CS88F
- CS68H
- CS77
- CS77H
- MASTERLINE8
- SLIMLINE38
- S560
- S560 Mono

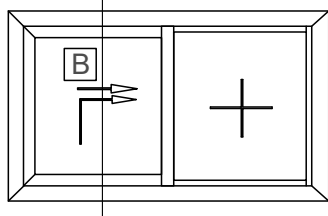

lift & slide-200 kg

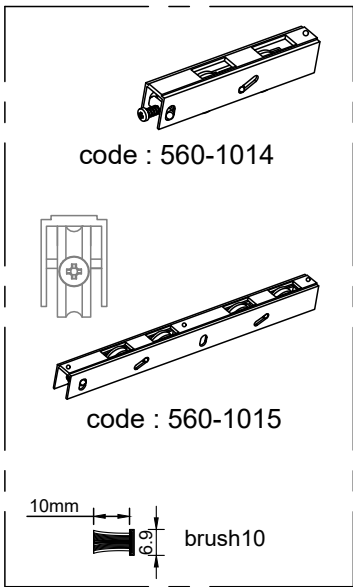
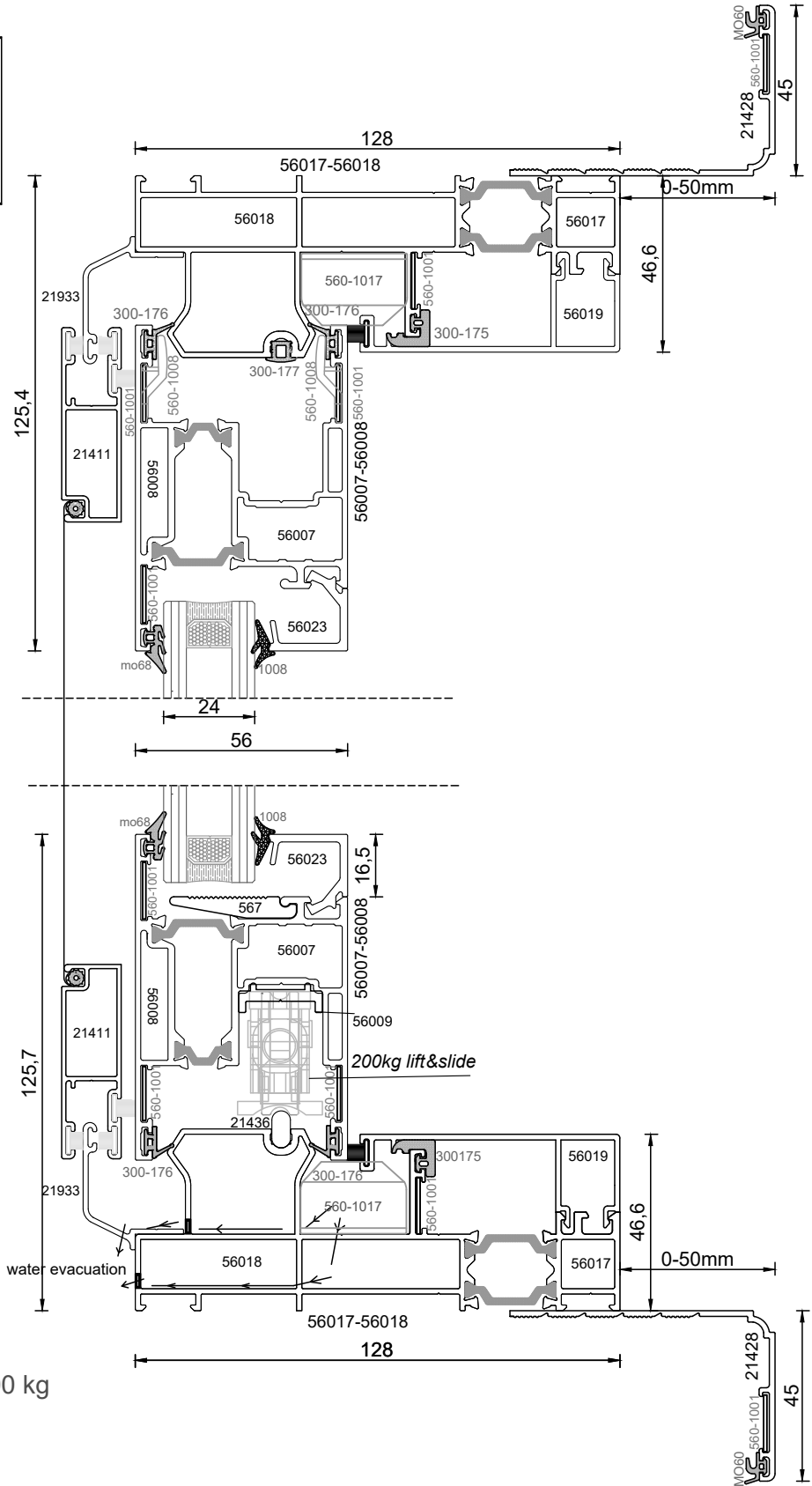

**B**  
lift & slide-200 kg

- CS59
- CS68
- CS68F
- CS68H
- CS77
- CS77H
- MASTERLINE8
- SLIMLINE38
- S560
- S560 Mono

CS59

CS68

CS68F

CS68H

CS77

CS77H

MASTERLINE8

SLIMLINE38

S560

S560 Mono

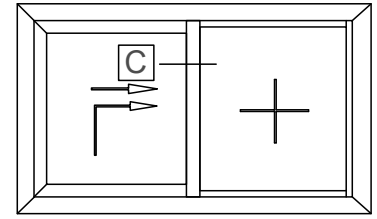
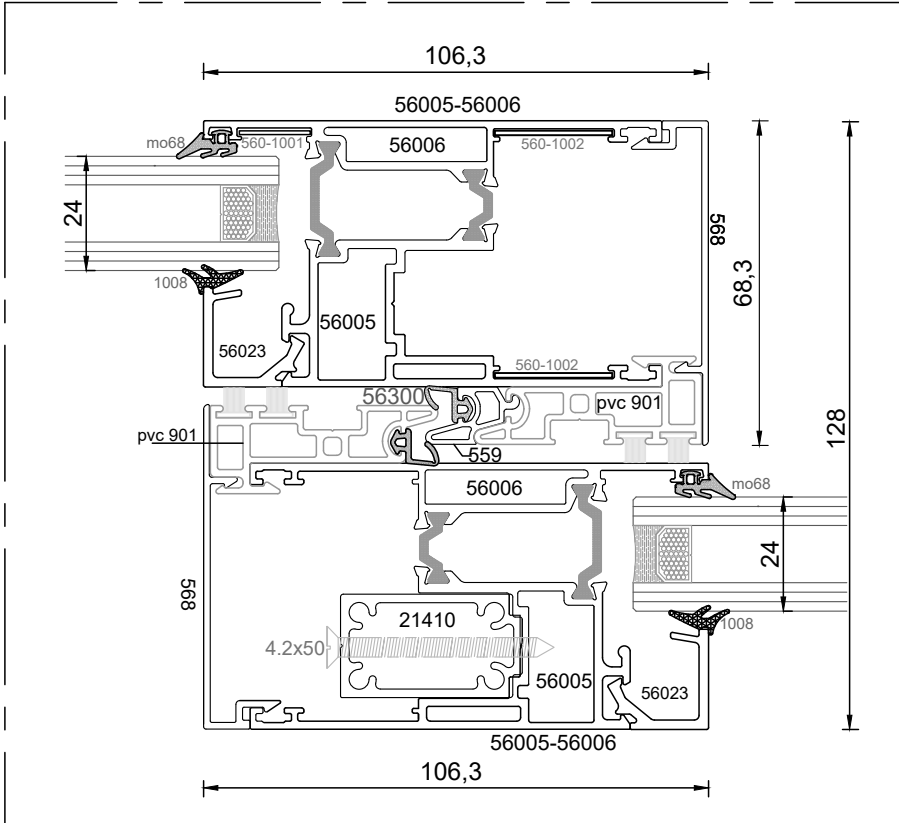

lift & slide-300kg

C1

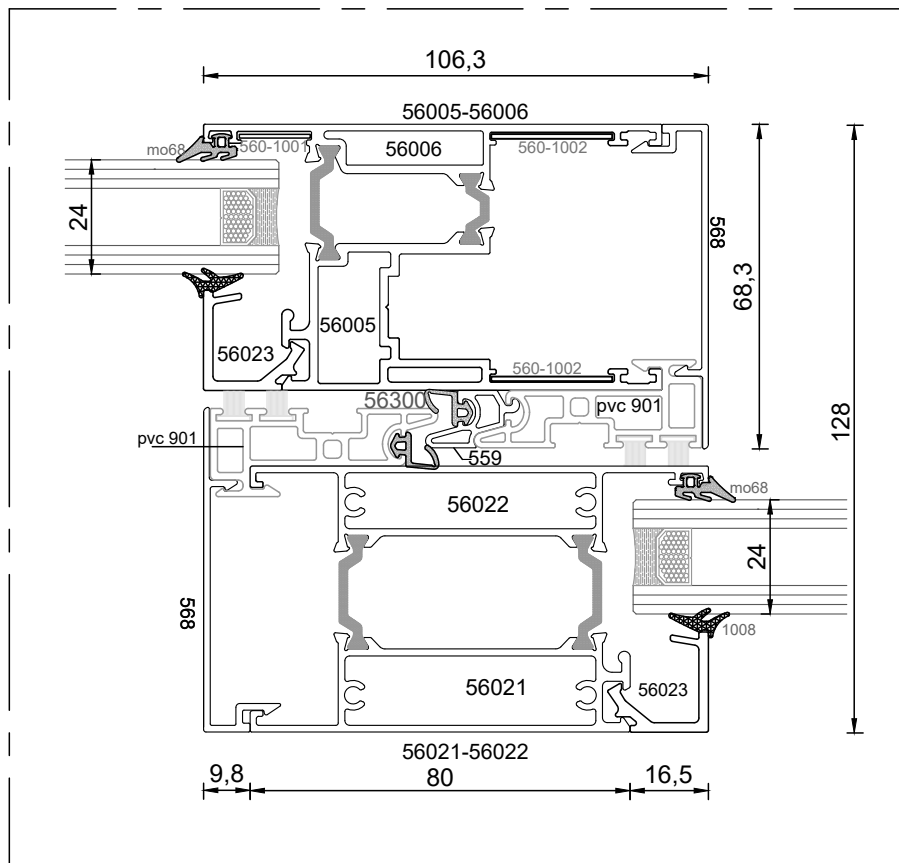

C2

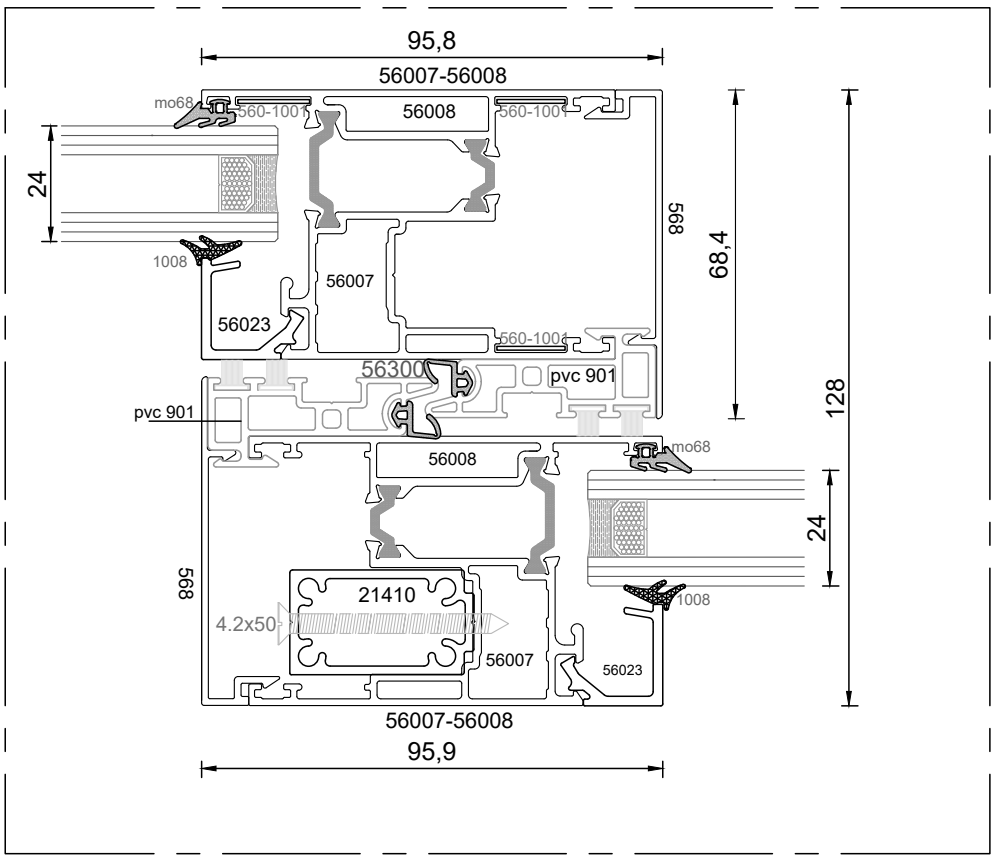

**D1**

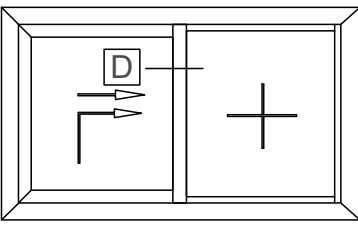

lift & slide-200kg

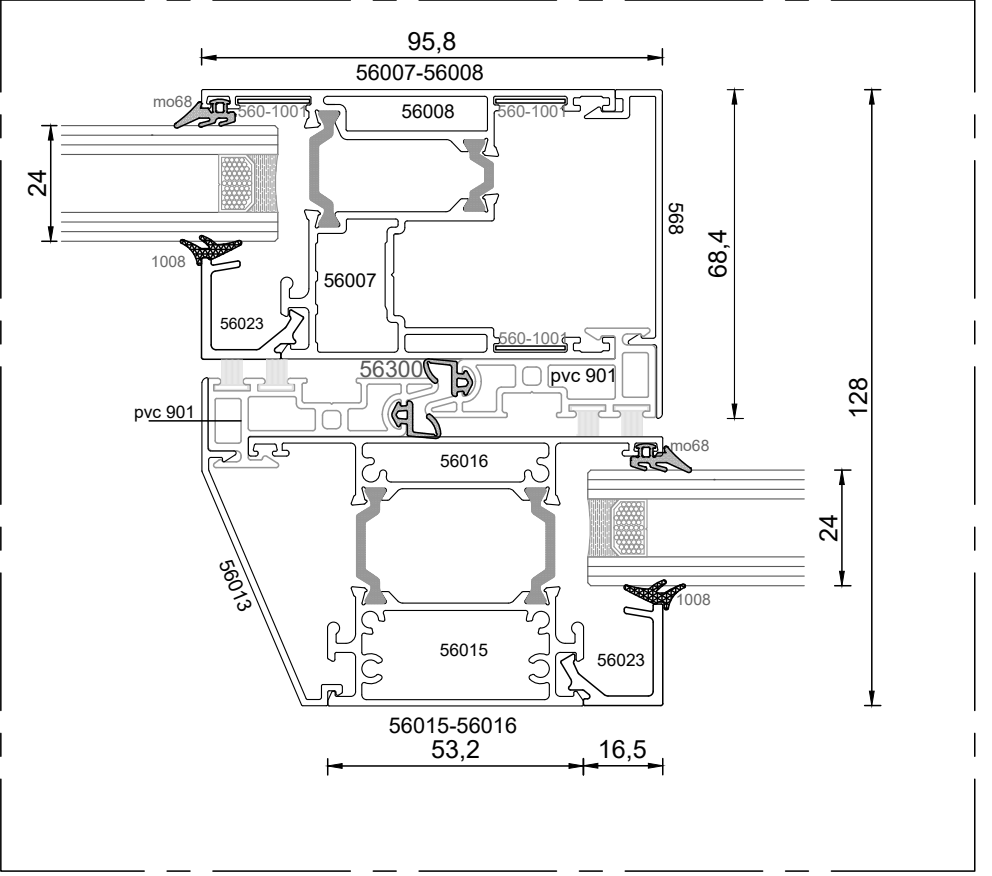

**D2**

- CS59
- CS68
- CS68F
- CS68H
- CS77
- CS77H
- MASTERLINE8
- SLIMLINE38
- S560
- S560 Mono

# SECTIONS

S560 MONO RAIL - LIFT & SLIDING INSULATED SYSTEM



CS59

CS68

CS68F

CS68H

CS77

CS77H

MASTERLINE8

SLIMLINE38

S560

S560 Mono

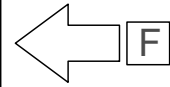
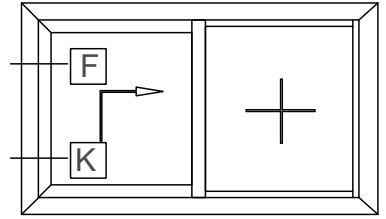
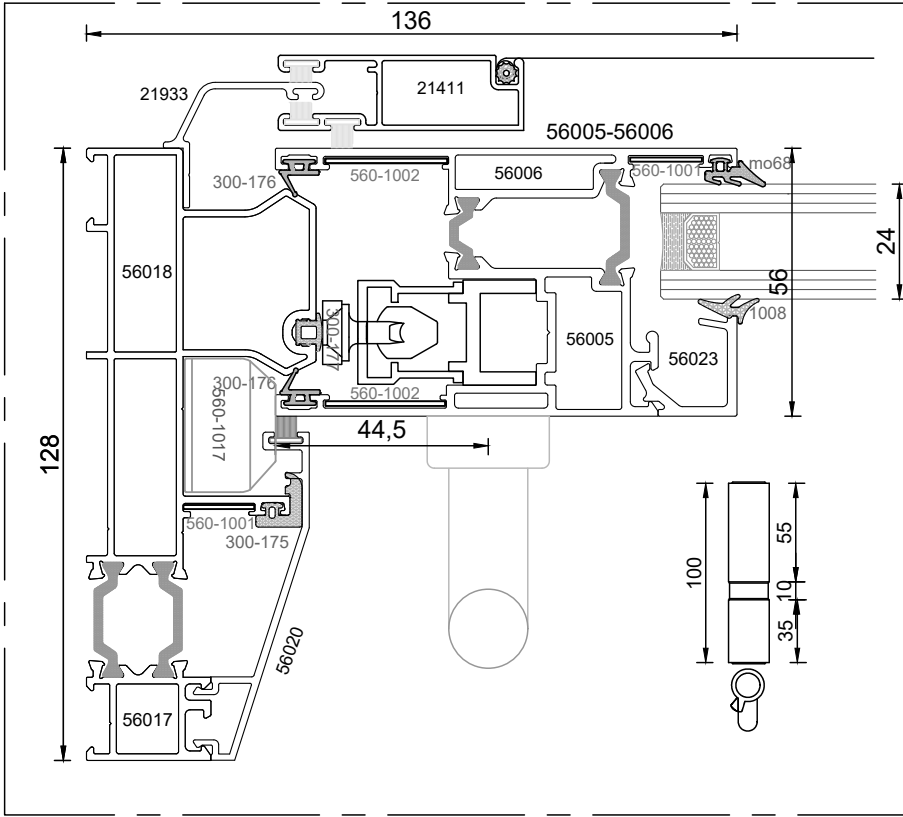

lift & slide-300kg

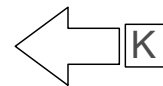
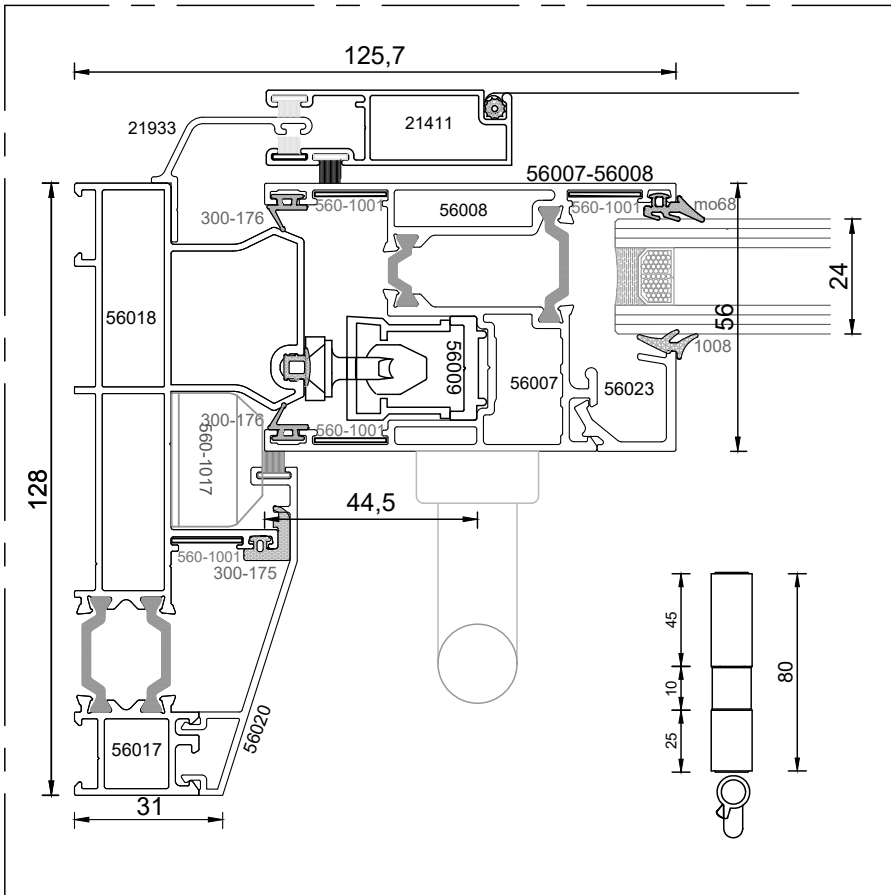

lift & slide-200kg



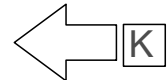
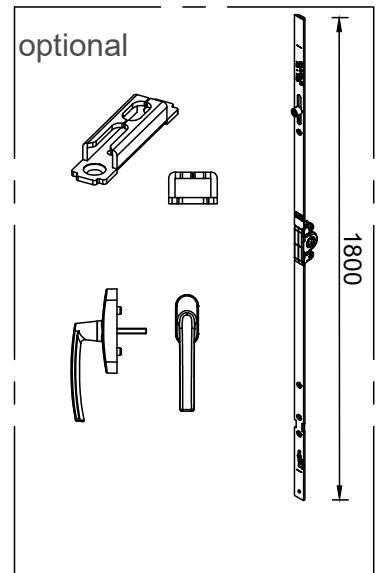
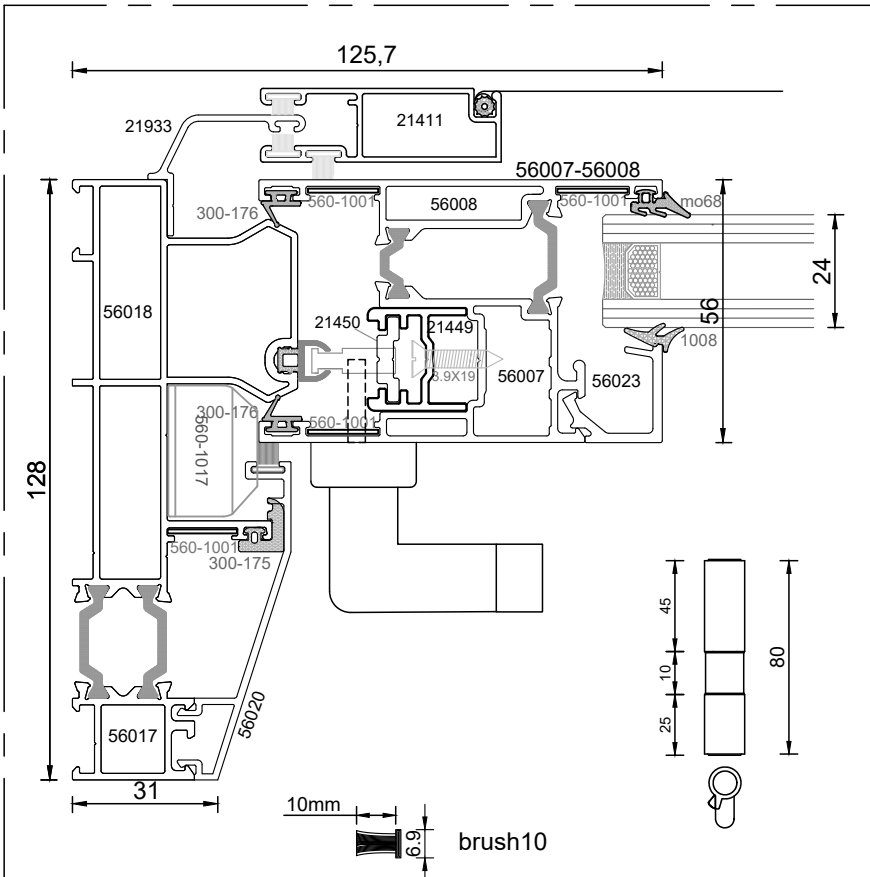
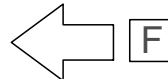
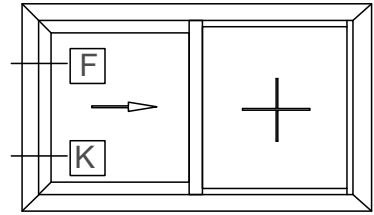
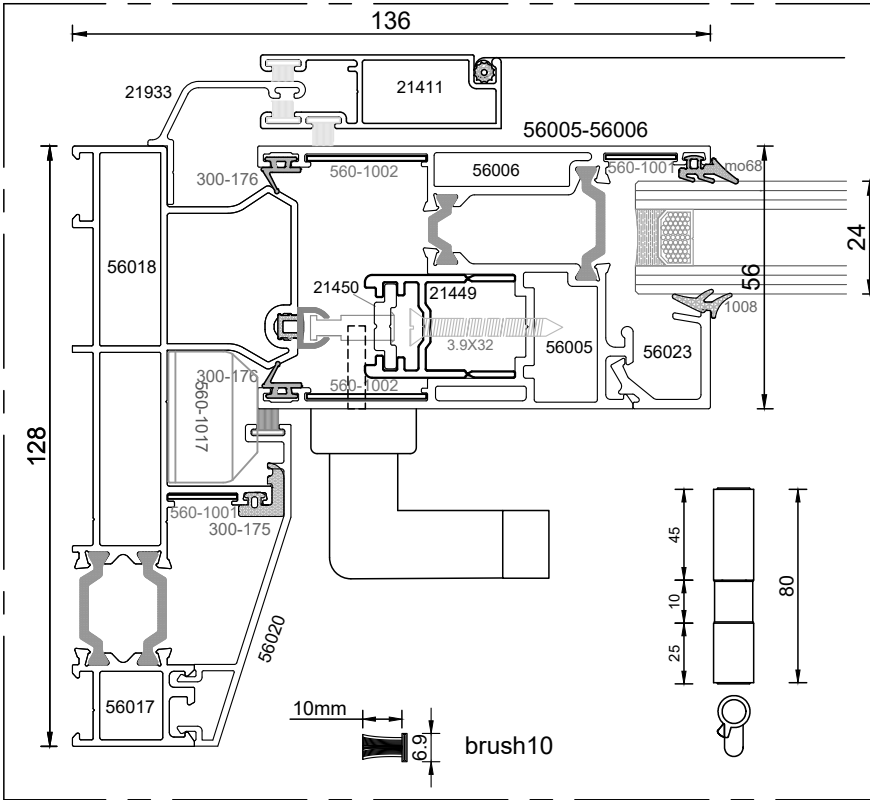

- CS59
- CS68
- CS68F
- CS68H
- CS77
- CS77H
- MASTERLINE8
- SLIMLINE38
- S560
- S560 Mono

CS59

CS68

CS68F

CS68H

CS77

CS77H

MASTERLINE8

SLIMLINE38

S560

S560 Mono

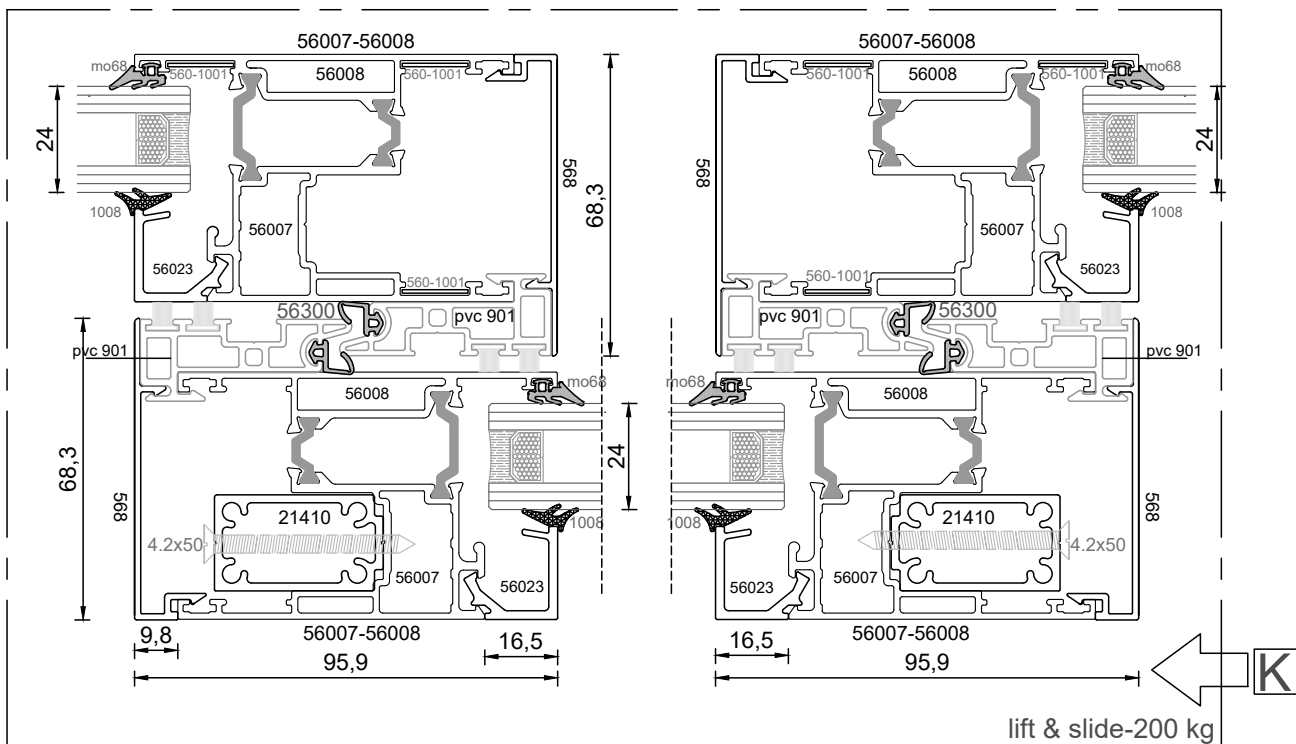
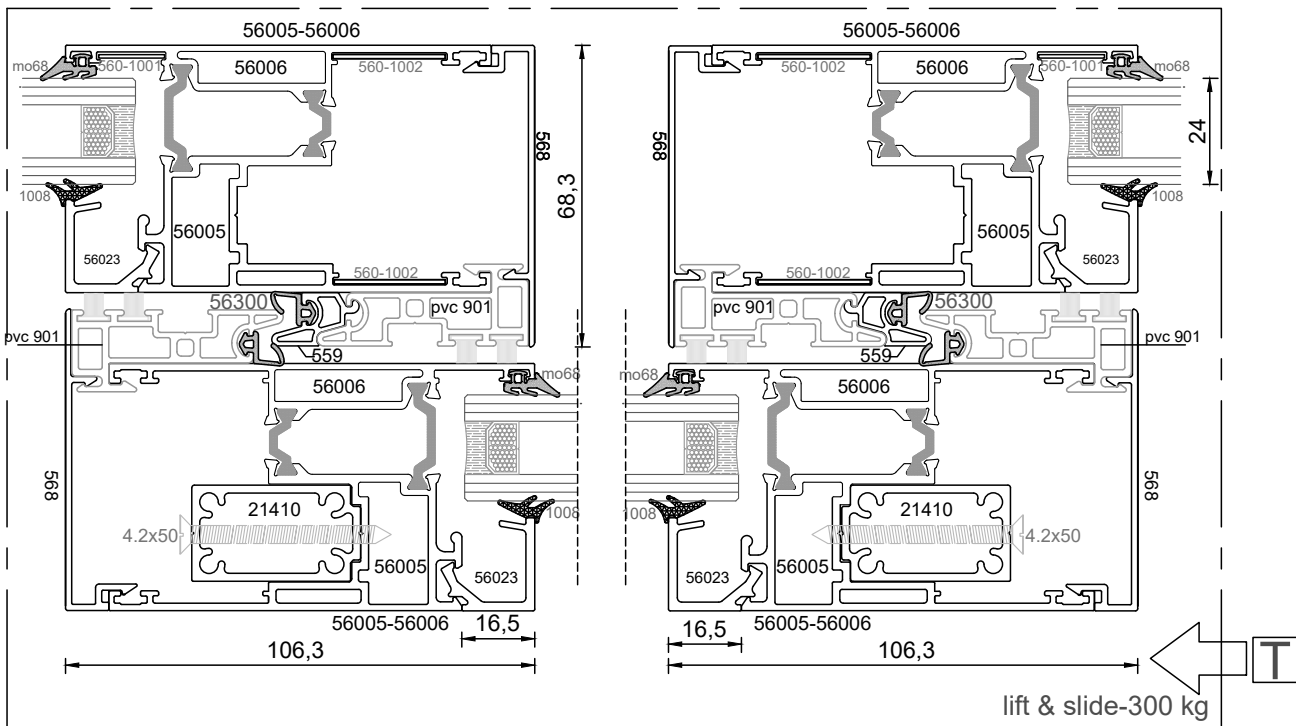
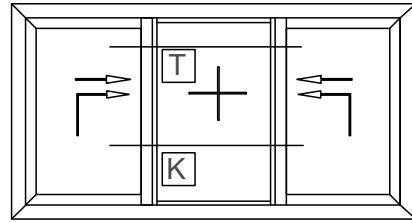

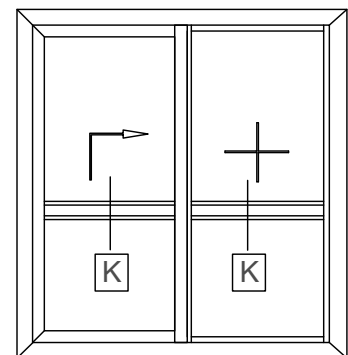
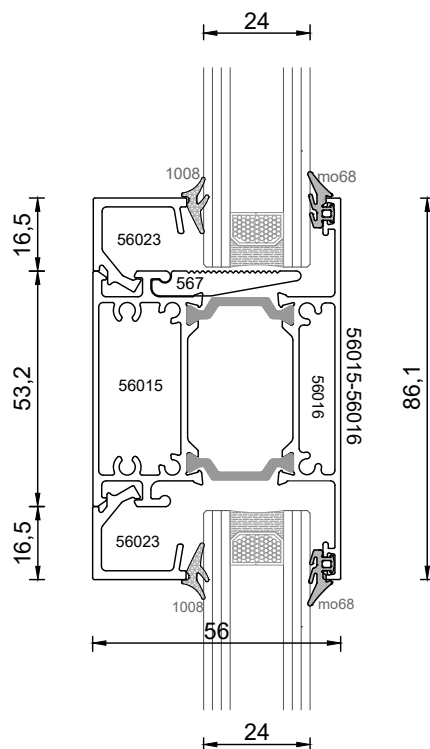
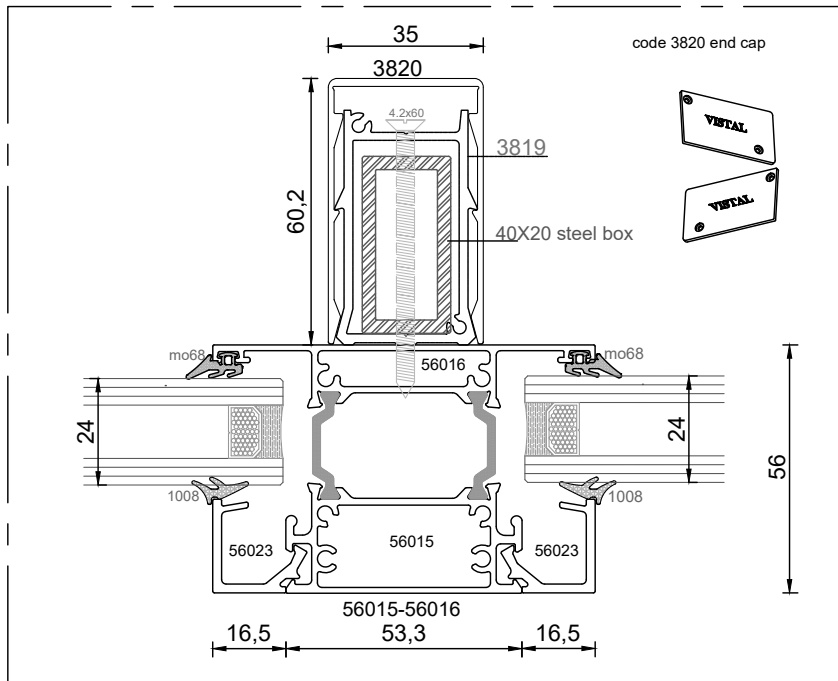
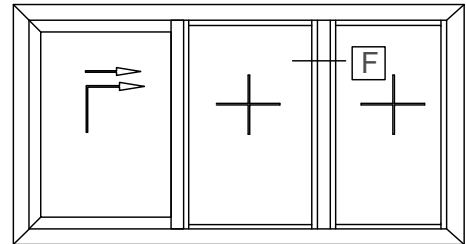

- CS59
- CS68
- CS68F
- CS68H
- CS77
- CS77H
- MASTERLINE8
- SLIMLINE38
- S560
- S560 Mono

# SECTIONS

S560 MONO RAIL - LIFT & SLIDING INSULATED SYSTEM

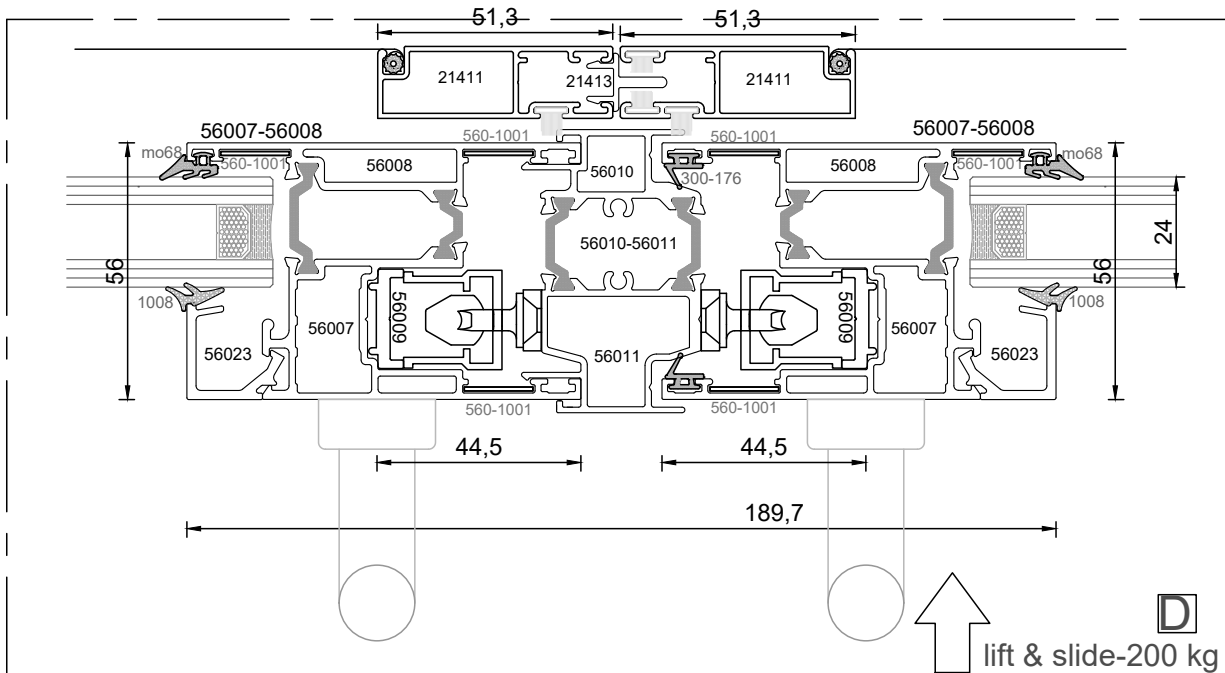
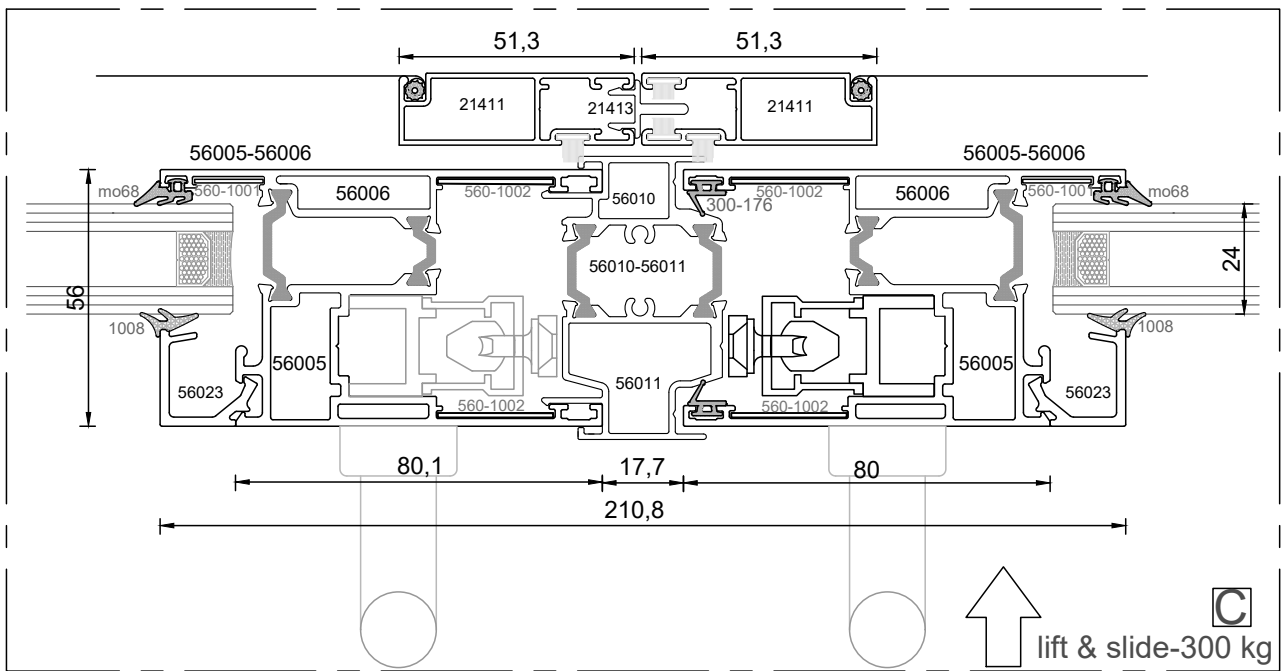
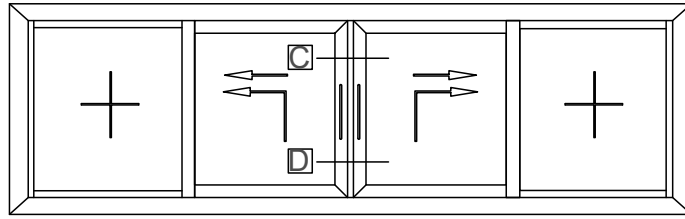
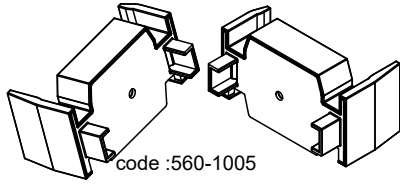

CS59

CS68

CS68F

CS68H

CS77

CS77H



MASTERLINE8

SLIMLINE38

S560

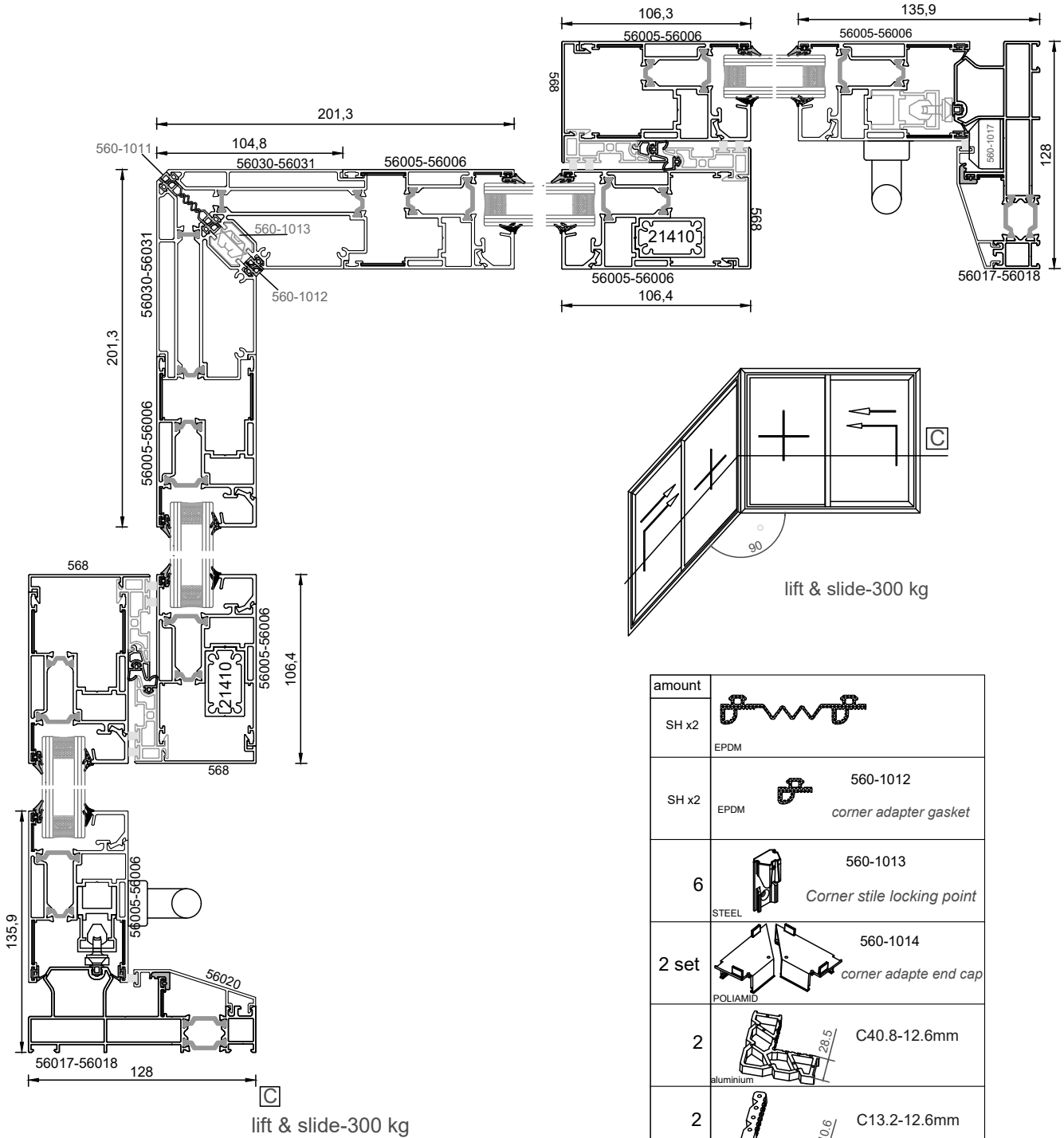
S560 Mono

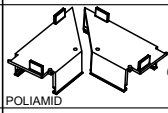
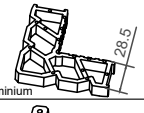
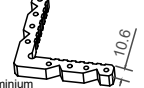

amount		
SH x2		EPDM
SH x2		560-1012 EPDM corner adapter gasket
6		560-1013 STEEL Corner stile locking point
2 set		560-1014 POLIAMID corner adapte end cap
2		C40.8-12.6mm aluminium
2		C13.2-12.6mm aluminium

- CS59
- CS68
- CS68F
- CS68H
- CS77
- CS77H
- MASTERLINE8
- SLIMLINE38
- S560
- S560 Mono





# SECTIONS

## S560 MONO RAIL - LIFT & SLIDING INSULATED SYSTEM

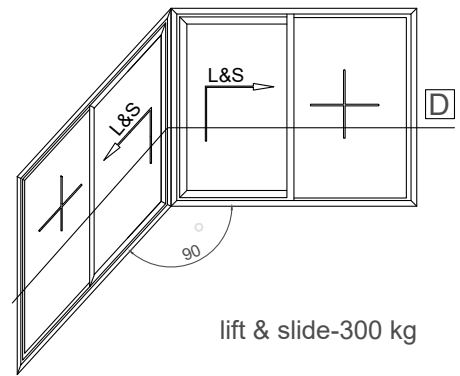
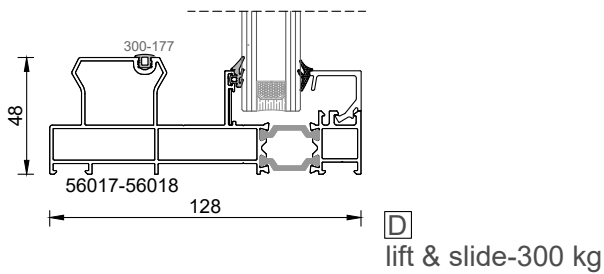
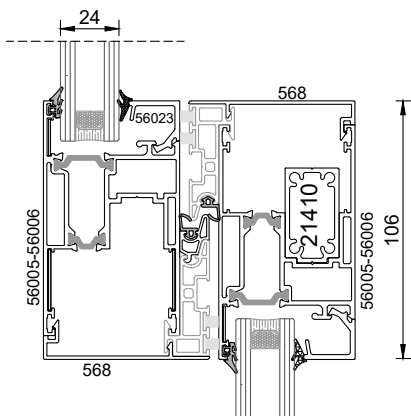
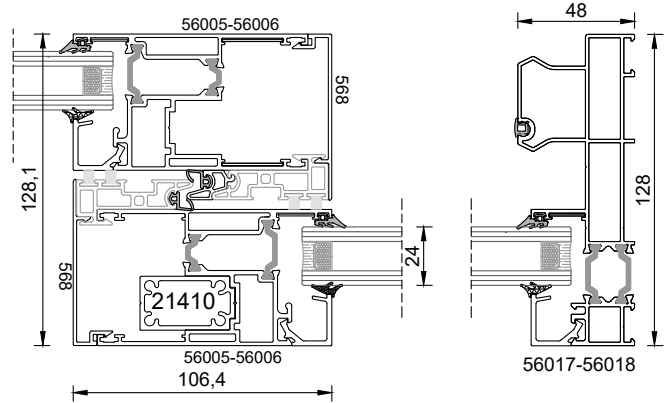
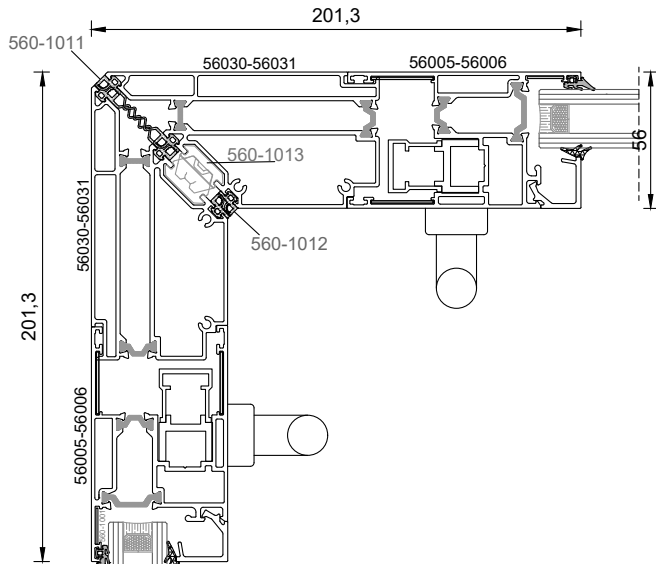

- CS59
- CS68
- CS68F
- CS68H
- CS77
- CS77H
- MASTERLINE8
- SLIMLINE38
- S560
- S560 Mono

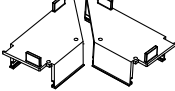
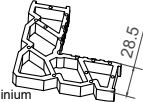

amount	
SH x2	 EPDM
SH x2	 560-1012 EPDM <i>corner adapter gasket</i>
6	 560-1013 STEEL <i>Corner stile locking point</i>
2 set	 560-1014 POLIAMID <i>corner adapte end cap</i>
2	 C40.8-12.6mm aluminium
4	 C13.2-12.6mm aluminium

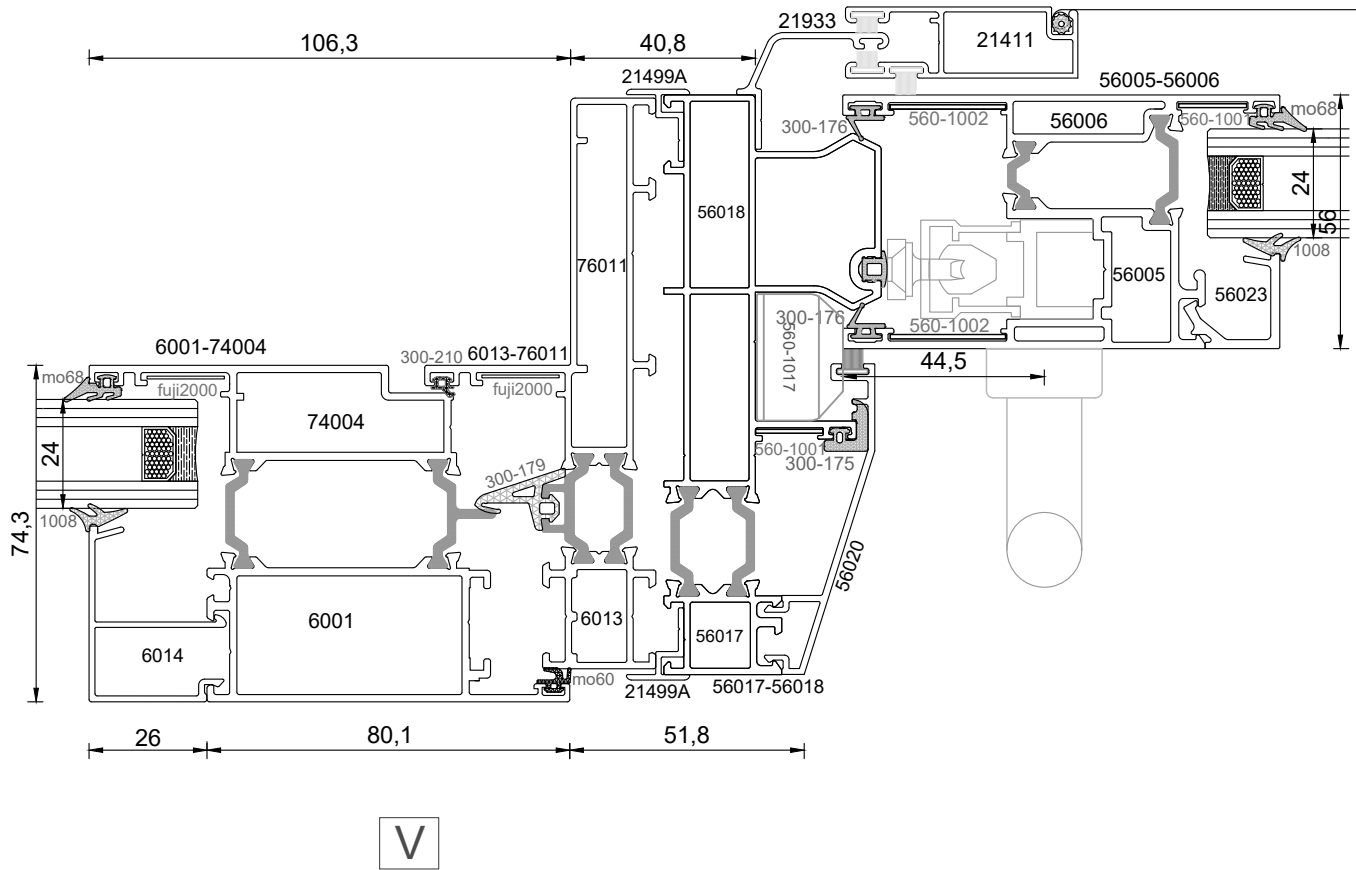
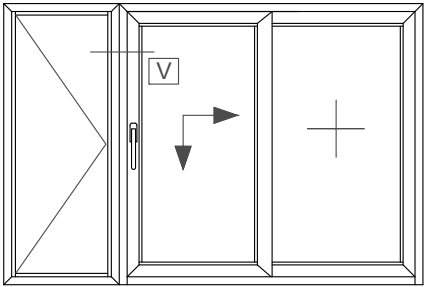

V

CS59
CS68
CS68F
CS68H
CS77
CS77H
MASTERLINE8
SLIMLINE38
S560
S560 Mono

# SECTIONS

S560

MONO RAIL - LIFT & SLIDING INSULATED SYSTEM



CS59

CS68

CS68F

CS68H

CS77

CS77H

MASTERLINE8

SLIMLINE38

S560

S560 Mono

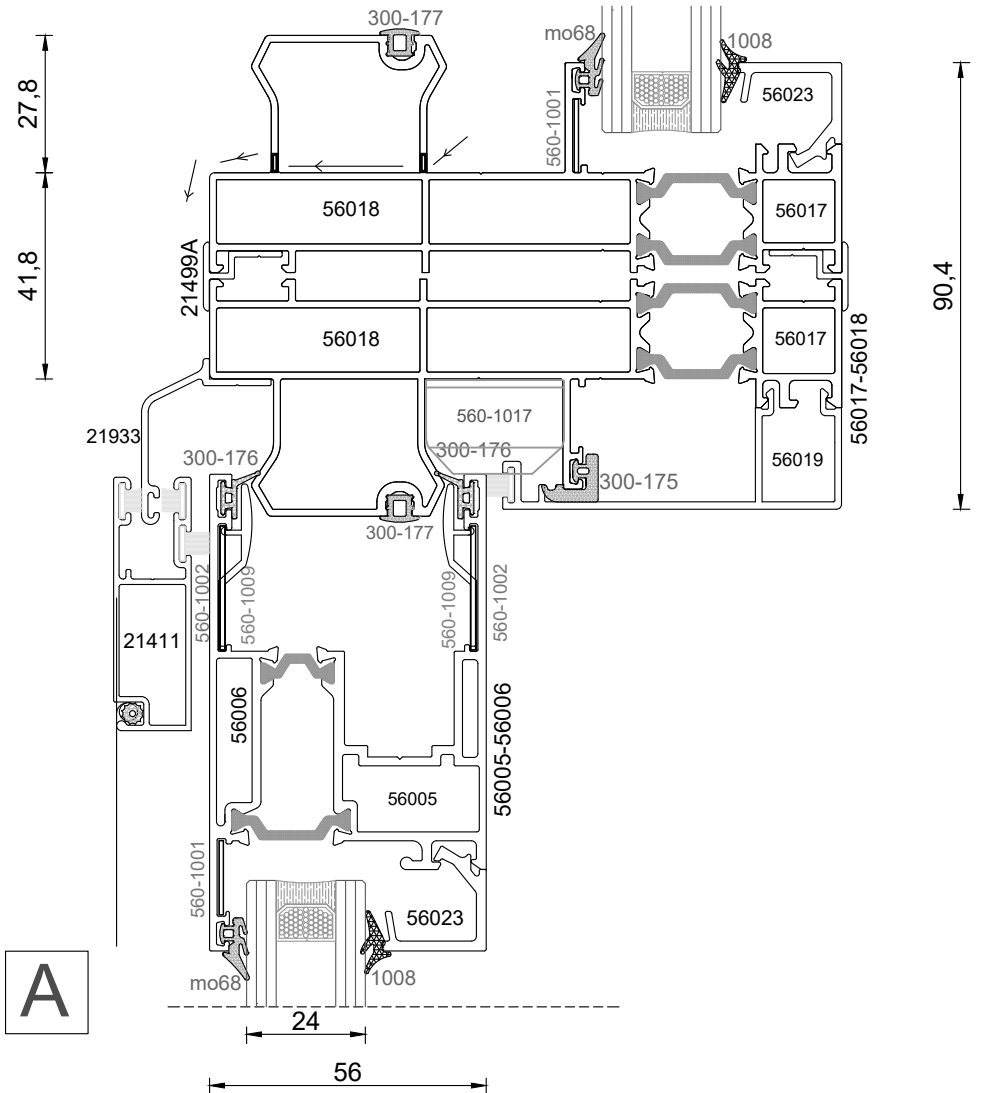
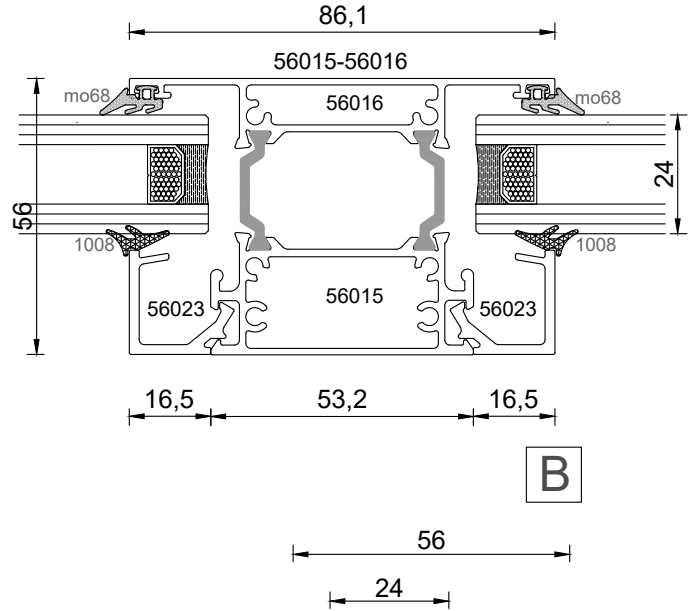
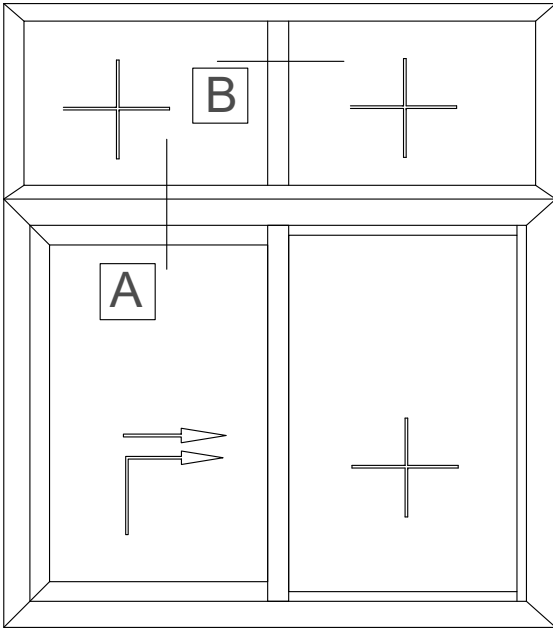



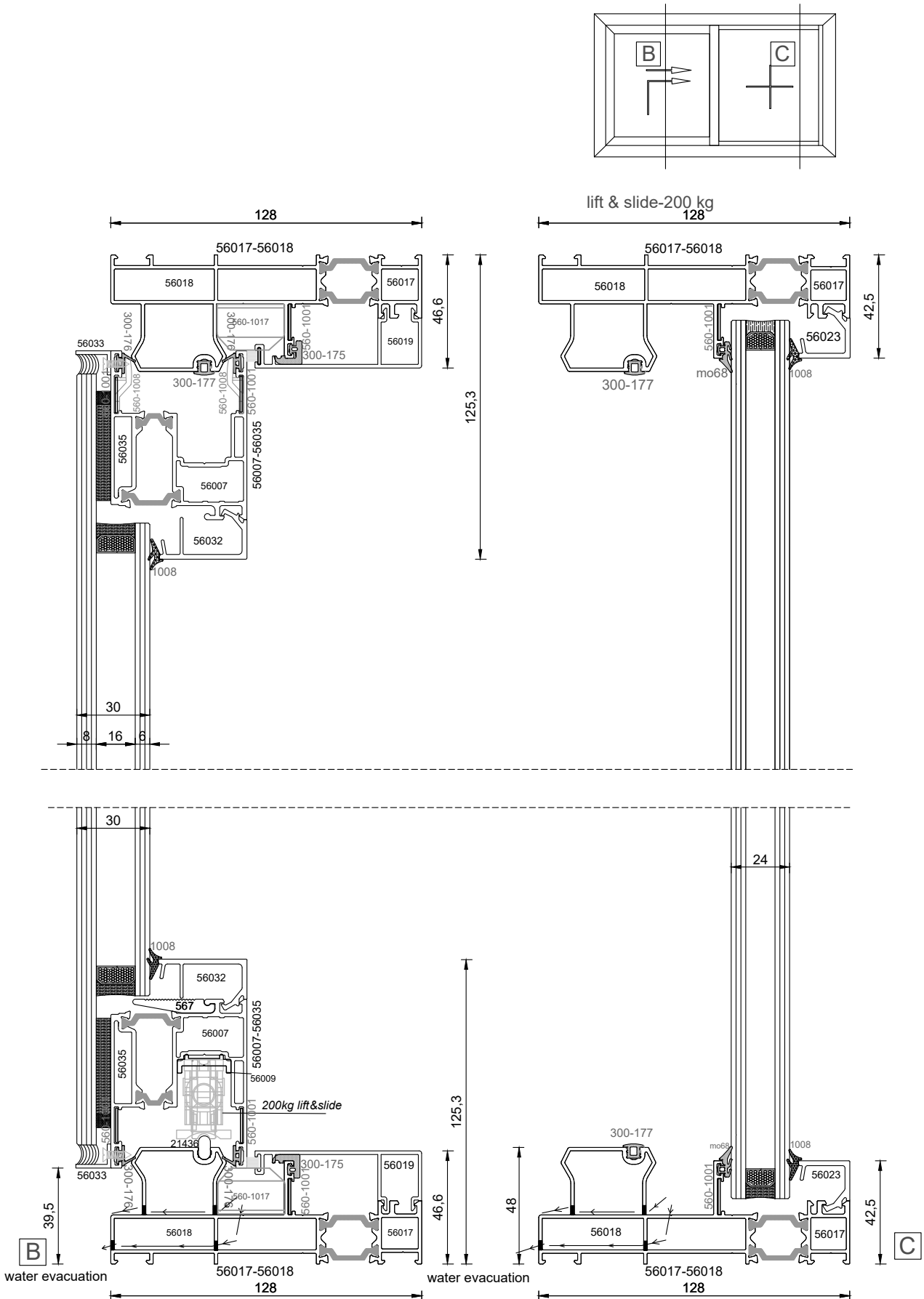

- CS59
- CS68
- CS68F
- CS68H
- CS77
- CS77H
- MASTERLINE8
- SLIMLINE38
- S560
- S560 Mono

CS59

CS68

CS68F

CS68H

CS77

CS77H

MASTERLINE8

SLIMLINE38

S560

S560 Mono

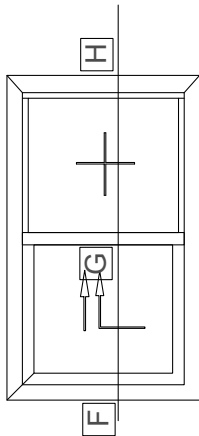

lift & slide-200 kg

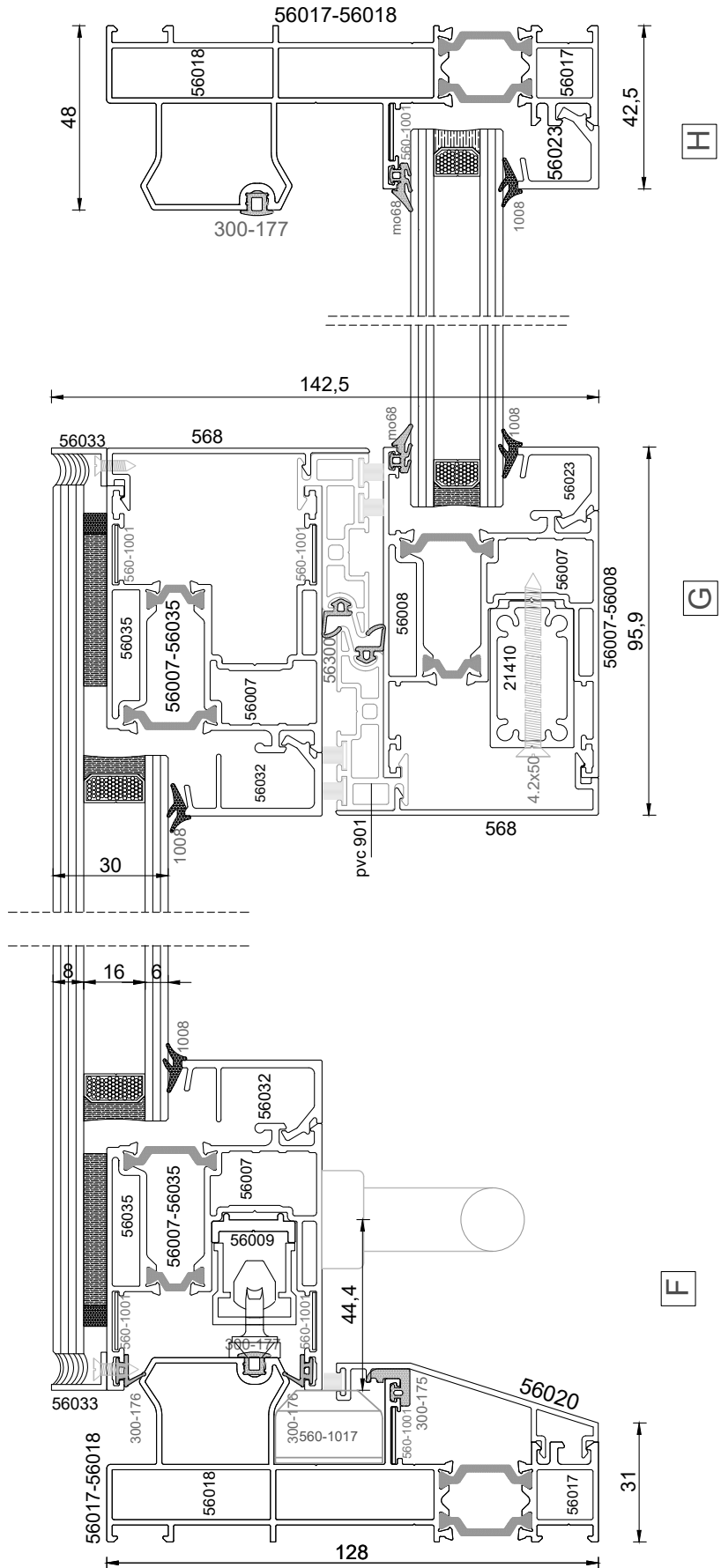

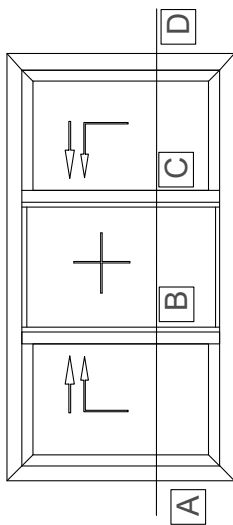

lift & slide-200 kg

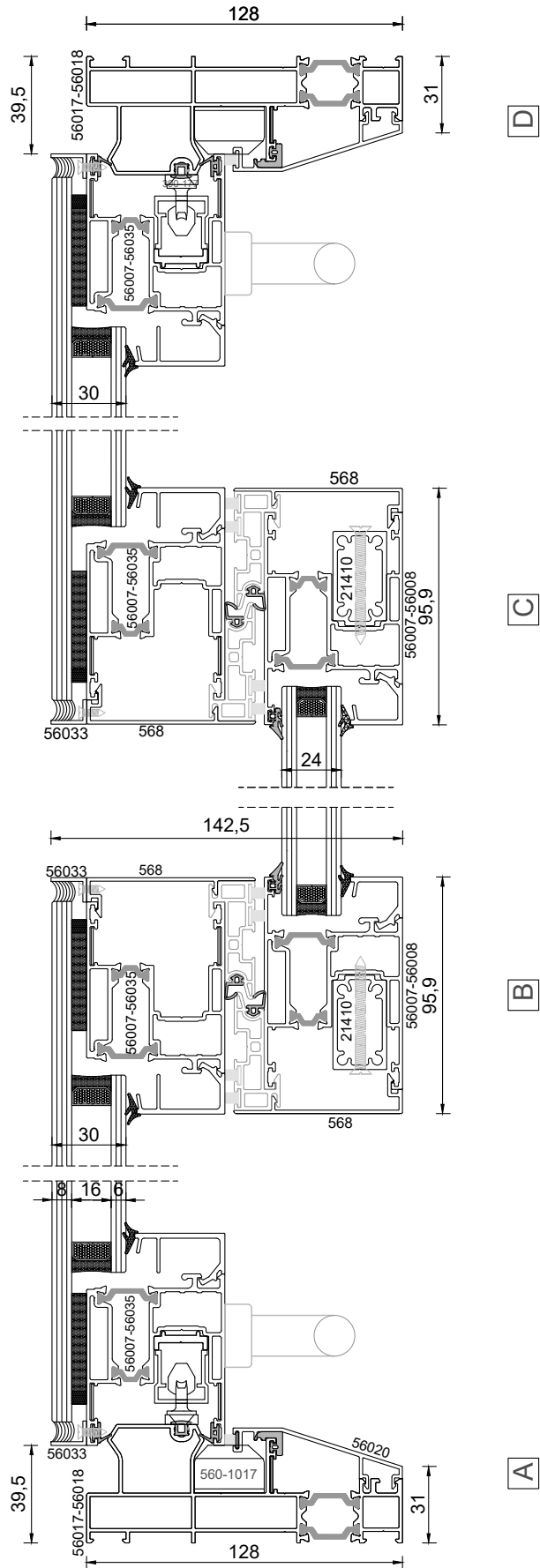



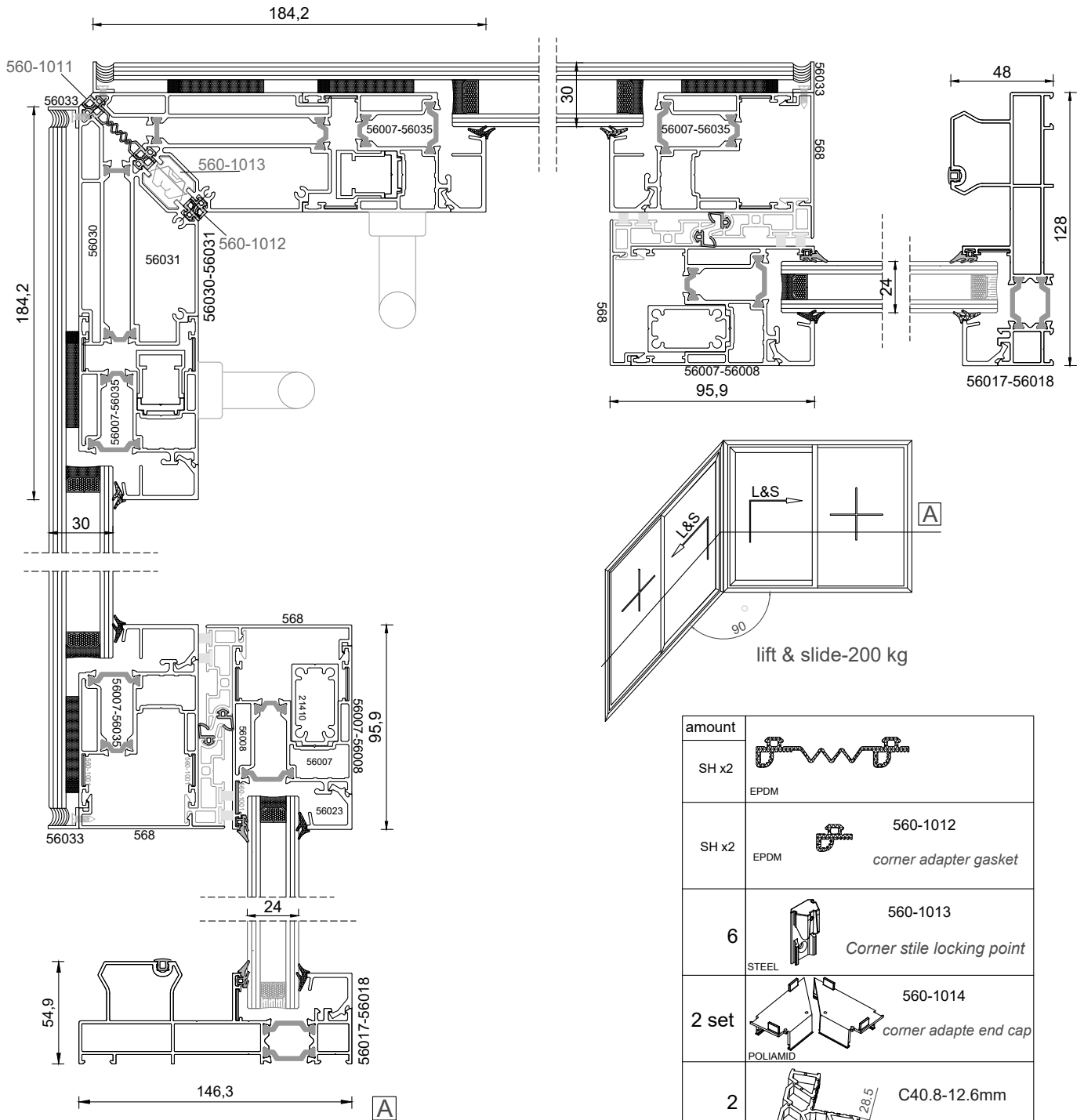

CS59
CS68
CS68F
CS68H
CS77
CS77H
MASTERLINE8
SLIMLINE38
S560
S560 Mono

# SECTIONS

## S560 MONO RAIL - LIFT & SLIDING INSULATED SYSTEM

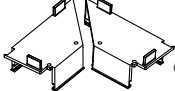

amount		
SH x2		EPDM
SH x2		560-1012 corner adapter gasket
6		560-1013 Corner stile locking point
2 set		560-1014 corner adapte end cap
2		aluminium C40.8-12.6mm
4		aluminium C13.2-12.6mm

- CS59
- CS68
- CS68F
- CS68H
- CS77
- CS77H
- MASTERLINE8
- SLIMLINE38
- S560
- S560 Mono

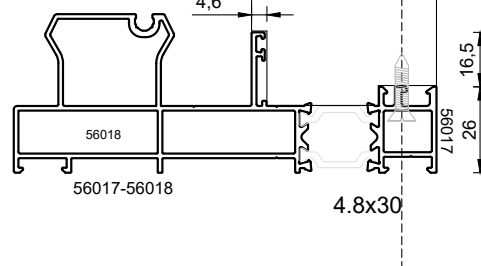
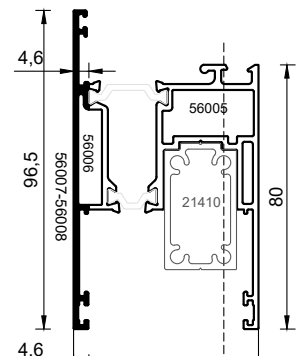
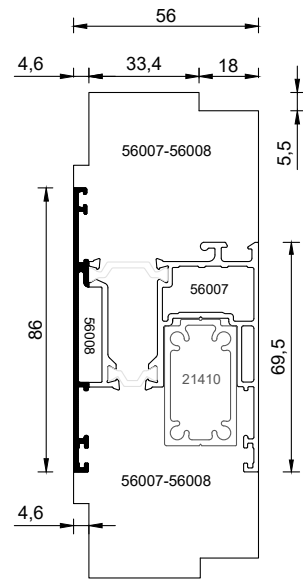
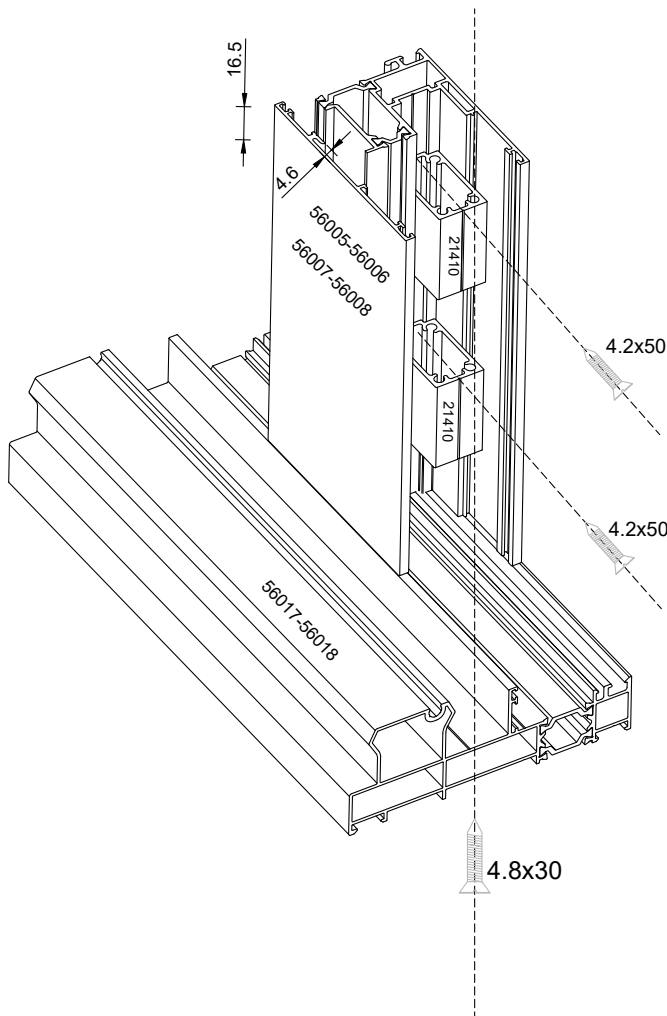
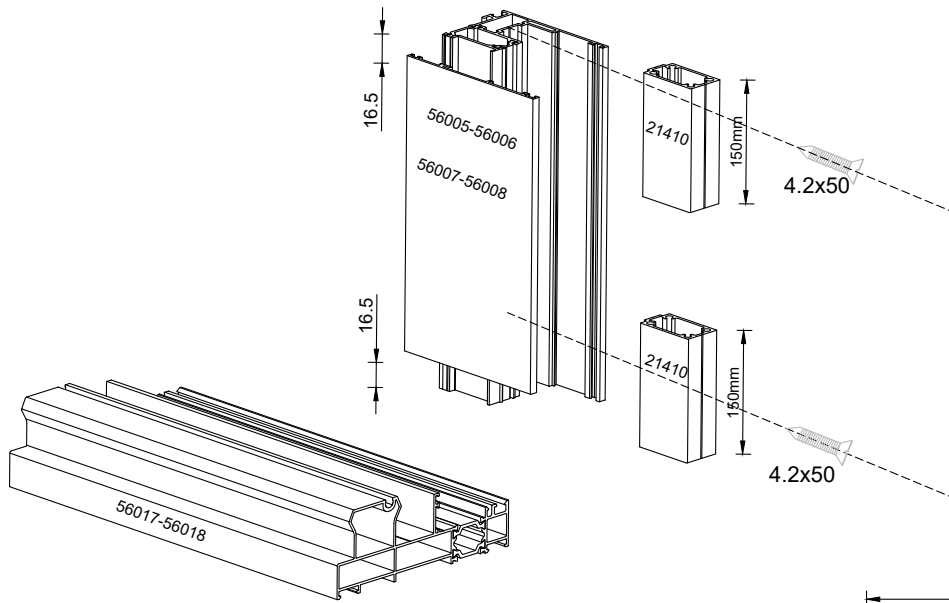

- CS59
- CS68
- CS68F
- CS68H
- CS77
- CS77H
- MASTERLINE8
- SLIMLINE38
- S560
- S560 Mono

# SECTIONS

S560

MONO RAIL - LIFT & SLIDING INSULATED SYSTEM



- CS59
- CS68
- CS68F
- CS68H
- CS77
- CS77H
- MASTERLINE8
- SLIMLINE38
- S560
- S560 Mono

