

TECHNICAL CATALOG

Aluminum Door Window And Facade System

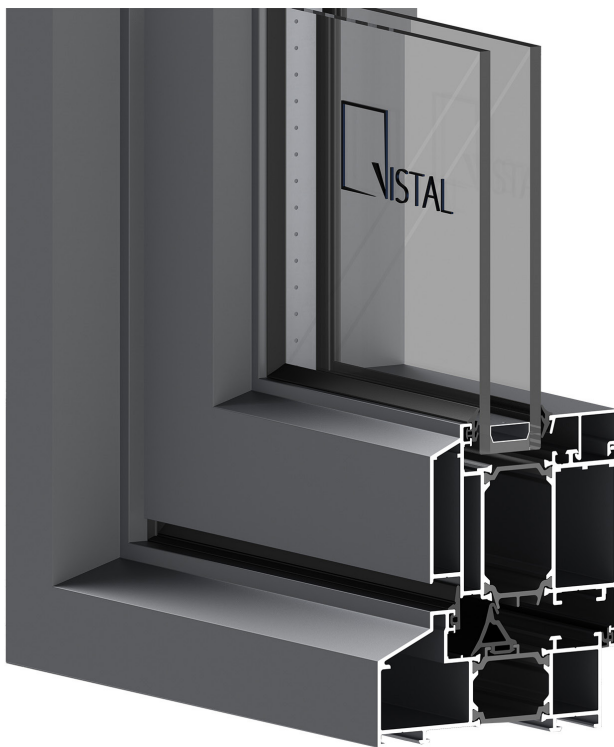

Frame width size: 99 mm

Sash width size: 70-83.2 mm

Profile wall thickness: 1.4-1.6 mm

Polyamide size: 30/34 mm

Glass thickness: 24-36 mm

Maximum opening weight: 160 kg

Maximum opening width: 1100 mm

Maximum opening height: 2500 mm

83MM SLIMITS

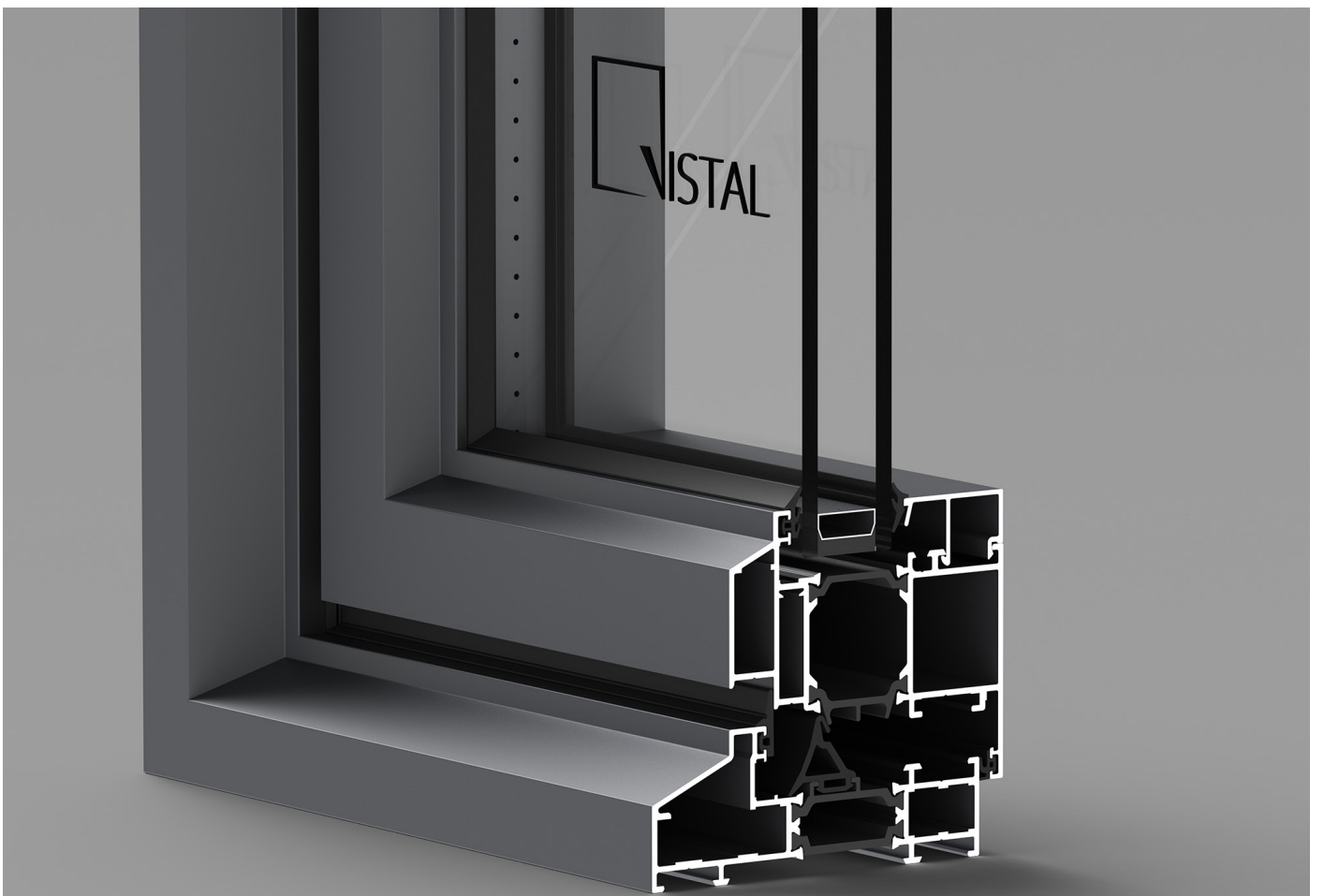
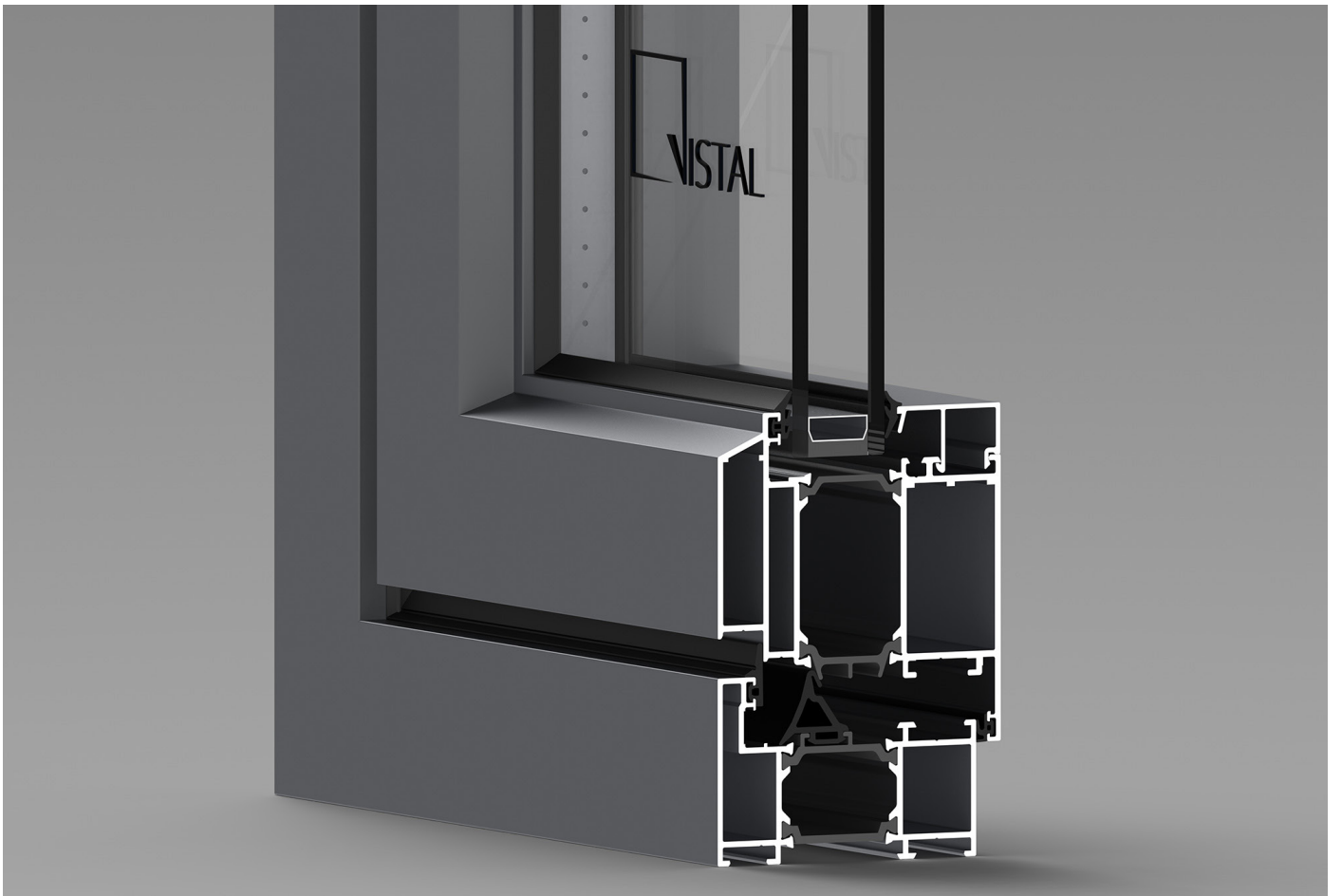

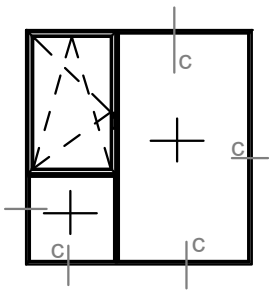

INWARD OPENING STEP WINDOW

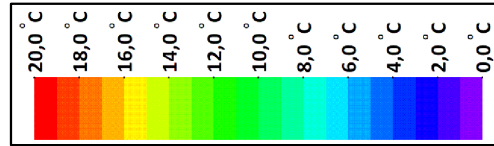

THERMAL CALCULATION CONDITIONS

(OUTER TEMPERATURE) : 0°C
 (ROOM TEMPERATURE) : 20°C
 (RELATIVE HUMIDITY) : %50

EN 10077-2

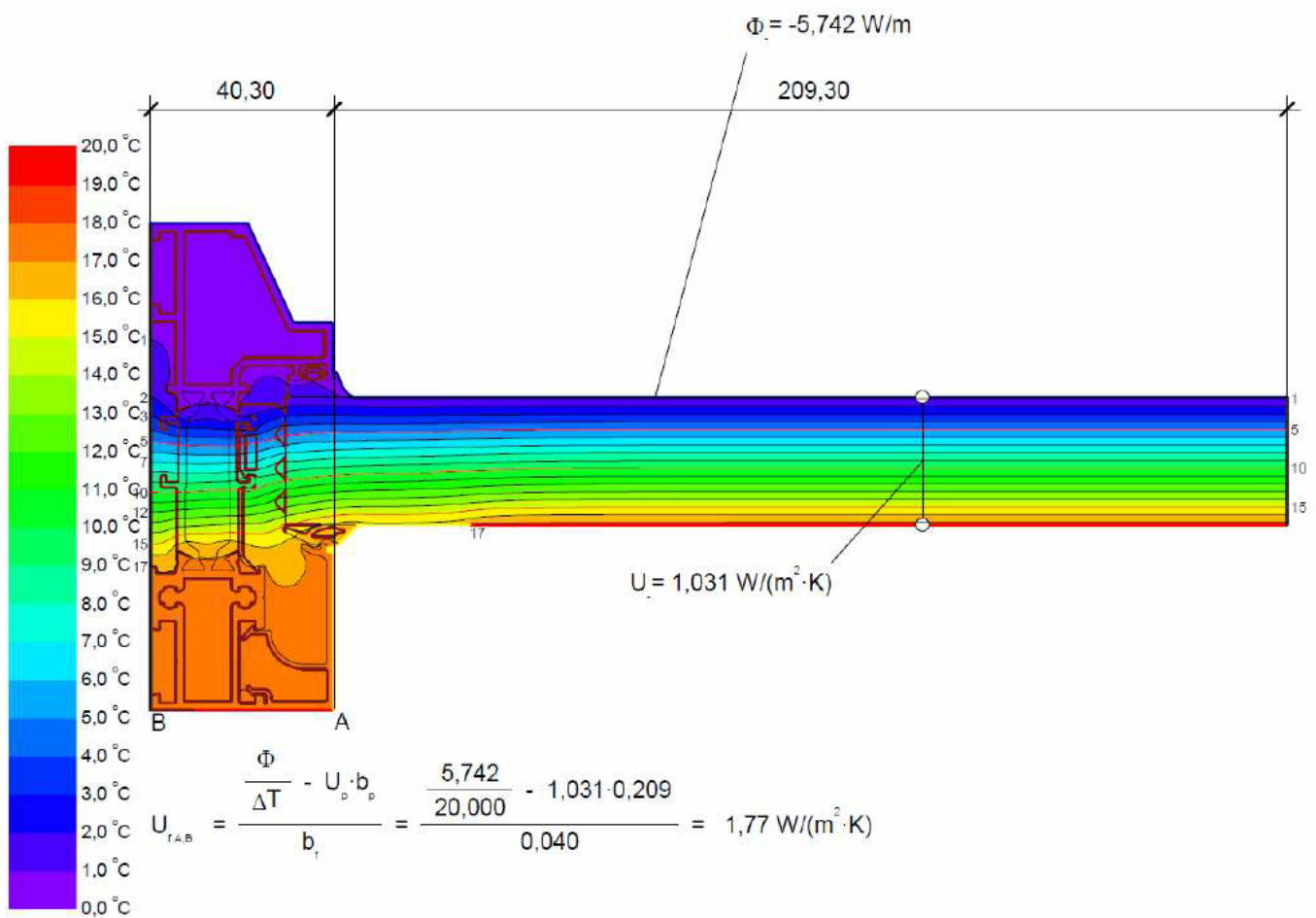

Material	λ [W/(m·K)]	ϵ	Boundary Condition	q [W/m ²]	θ [°C]	R [(m ² ·K)/W]	ϵ
Aluminium (Si Alloys)	160,000	0,900	Epsilon 0.9				0,900
EPDM (ethylene propylene diene monomer)	0,250	0,900	Exterior, frame	0,000		0,040	
Panel	0,035	0,900	Interior, frame, normal	20,000		0,130	
Polyamid 6.6 with 25% glass fibre	0,300	0,900	Interior, frame, reduced	20,000		0,200	
Polyethylene LD, low (Cam Altı Yalıtım)	0,014	0,900	Symmetry/Model section	0,000			
Unventilated air cavity	anisotropic						

AS EN 10077-2 standard , room temperature is 20°C ,outer temperature is 0°C and relative humidity is 50%.

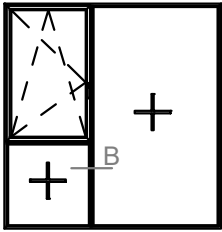

INWARD OPENING STEP WINDOW

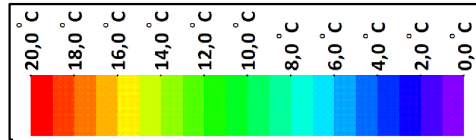

THERMAL CALCULATION CONDITIONS	
(OUTER TEMPERATURE)	: 0°C
(ROOM TEMPERATURE)	: 20°C
(RELATIVE HUMIDITY)	: %50
EN 10077-2	

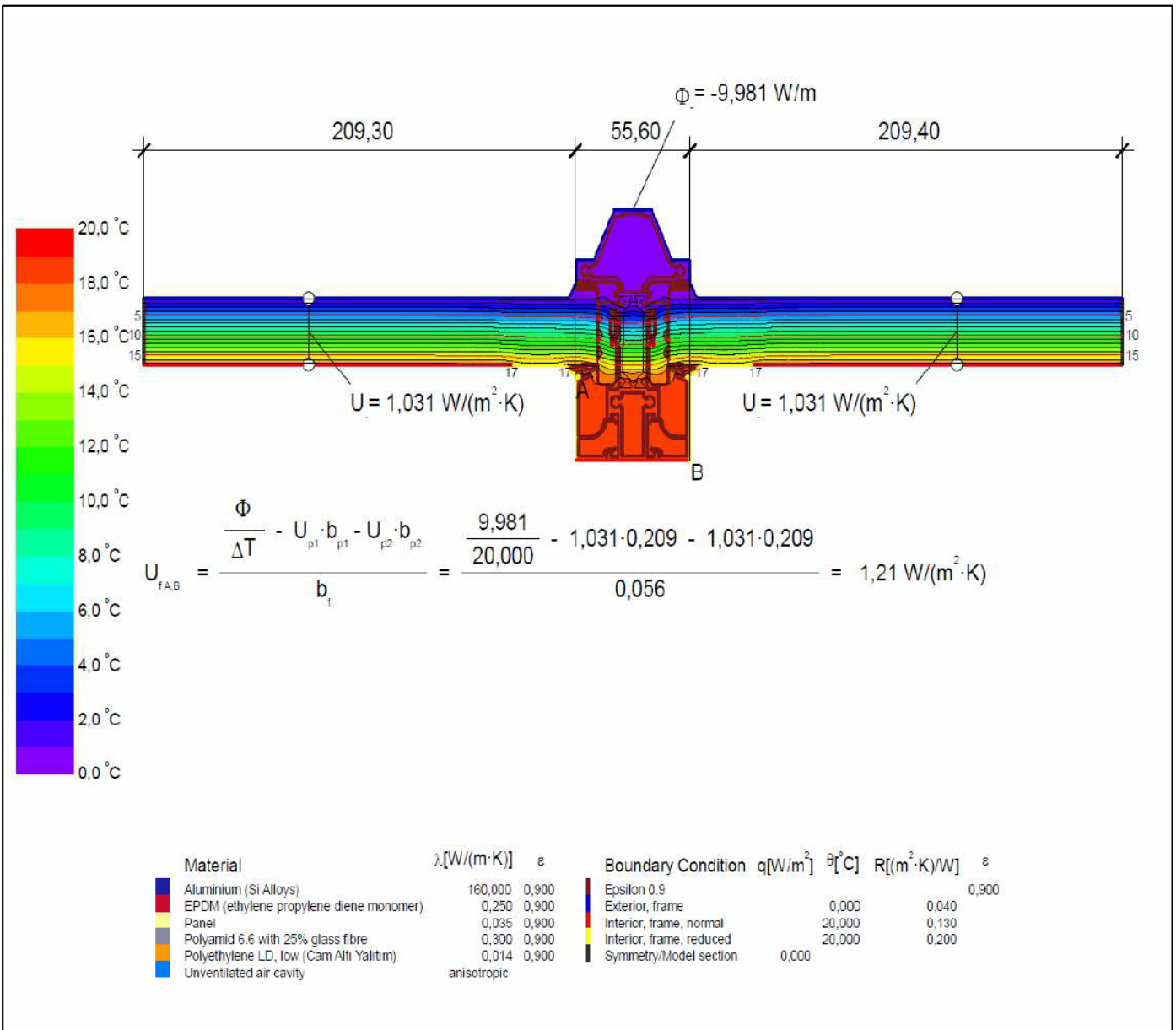

AS EN 10077-2 standard , room temperature is 20°C ,outer temperature is 0°C and relative humidity is 50%.

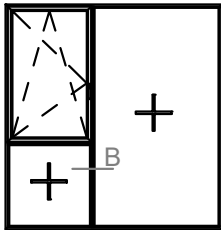

INWARD OPENING STEP WINDOW

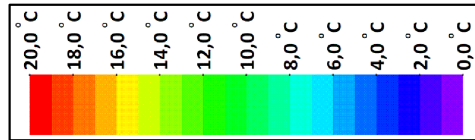

THERMAL CALCULATION CONDITIONS	
(OUTER TEMPERATURE)	: 0°C
(ROOM TEMPERATURE)	: 20°C
(RELATICE HUMIDITY)	: %50
EN 10077-2	

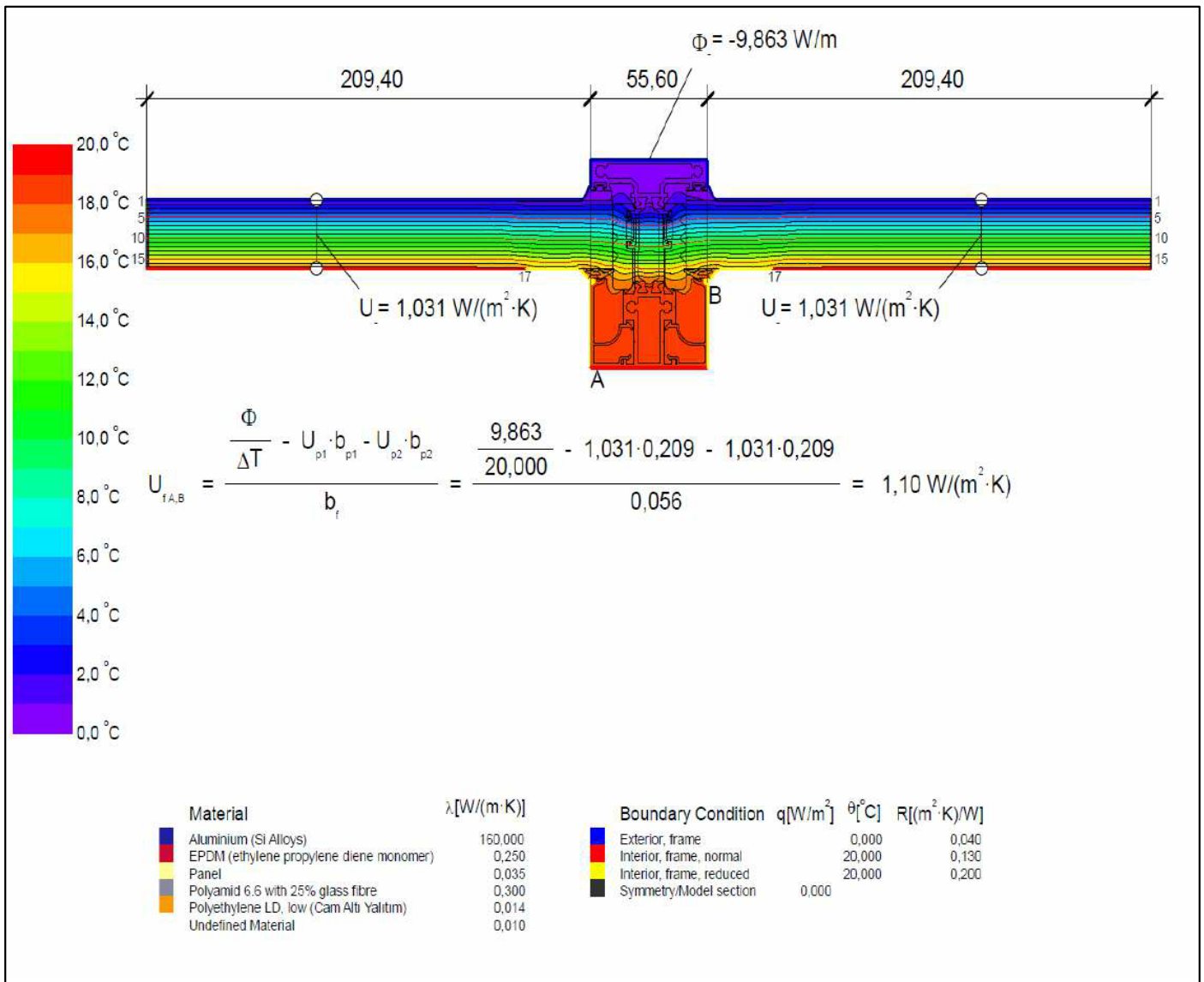

AS EN 10077-2 standard , room temperature is 20°C ,outer temperature is 0 C and relative humidity is 50%.

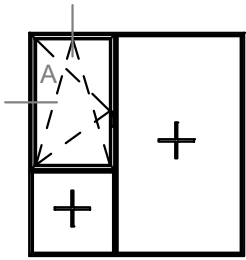

INWARD OPENING STEP WINDOW

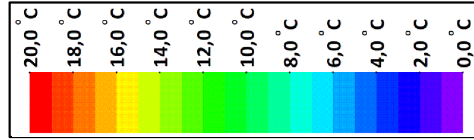

THERMAL CALCULATION CONDITIONS	
(OUTER TEMPERATURE)	: 0°C
(ROOM TEMPERATURE)	: 20°C
(RELATIVE HUMIDITY)	: %50
EN 10077-2	

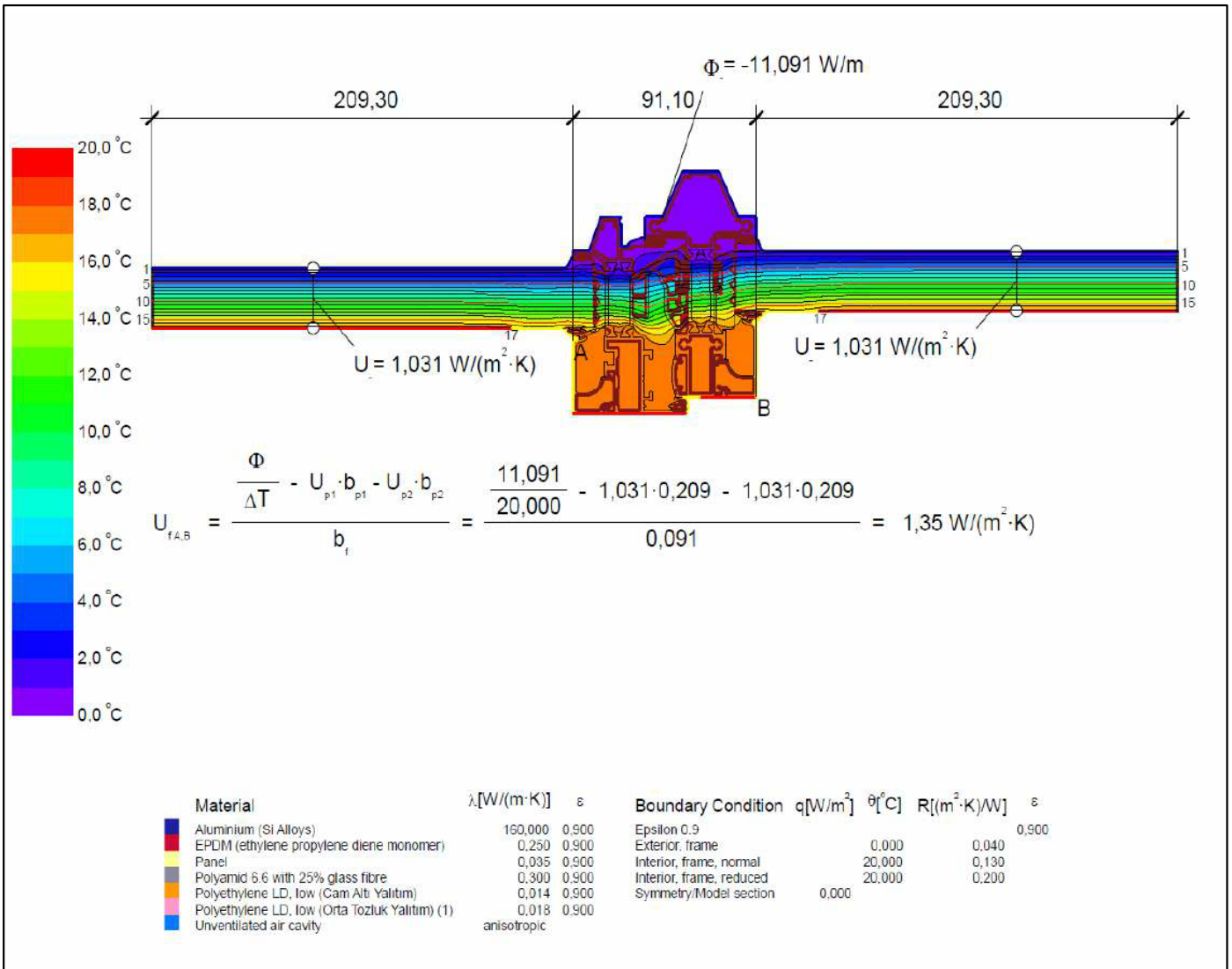

AS EN 10077-2 standard , room temperature is 20°C ,outer temprature is 0 C and relative humidity is 50%.

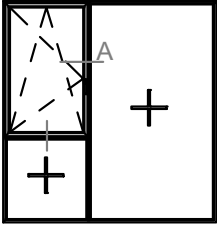

INWARD OPENING STEP WINDOW

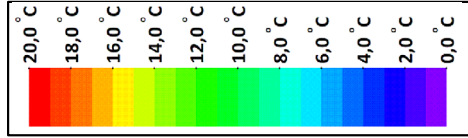

THERMAL CALCULATION CONDITIONS	
(OUTER TEMPERATURE)	: 0°C
(ROOM TEMPERATURE)	: 20°C
(RELATIVE HUMIDITY)	: %50
EN 10077-2	

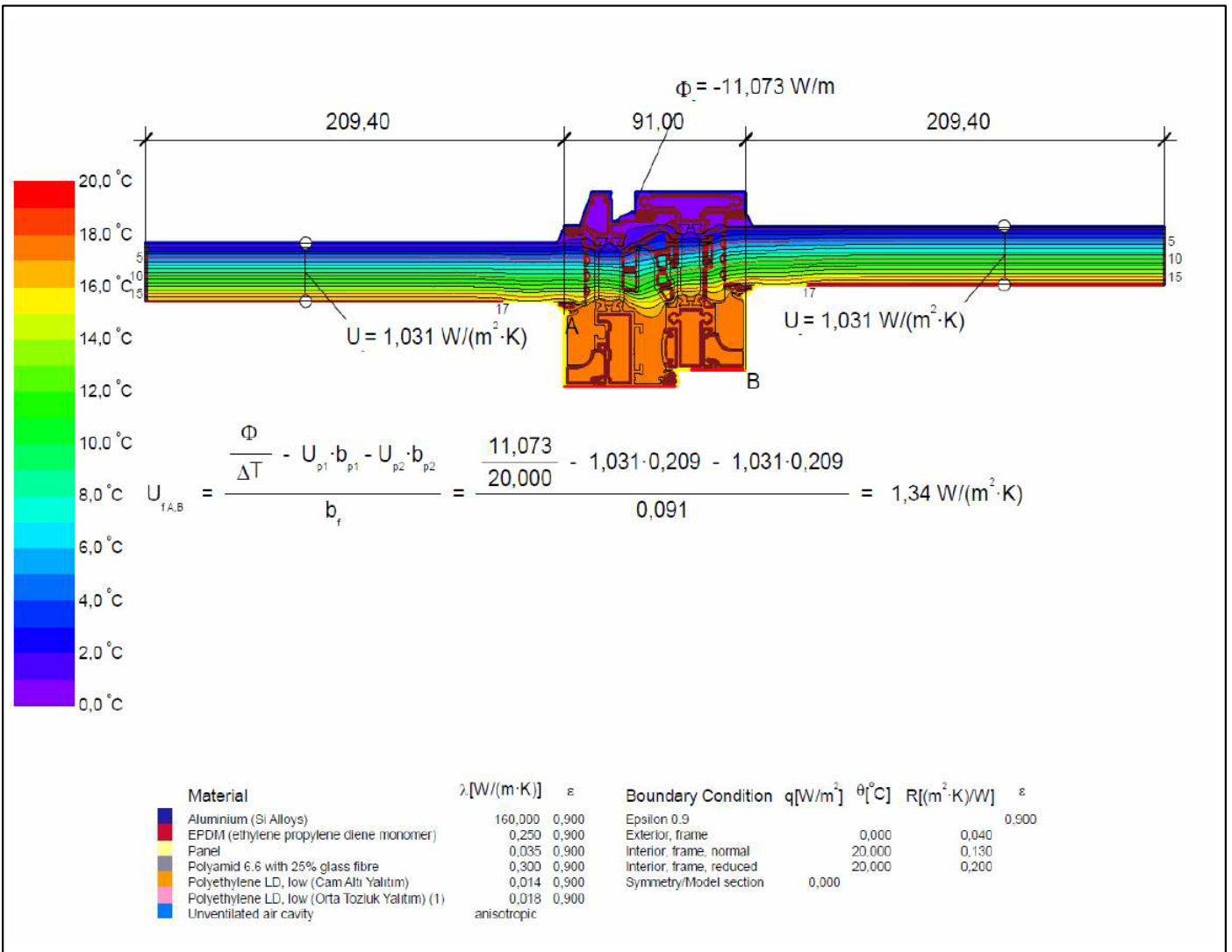

AS EN 10077-2 standard , room temperature is 20°C ,outer temprature is 0 C and relative humidity is 50%.

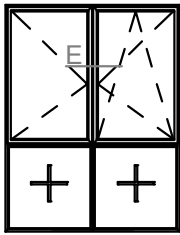

INWARD OPENING STEP WINDOW

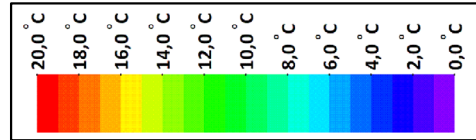

THERMAL CALCULATION CONDITIONS	
(OUTER TEMPERATURE)	: 0°C
(ROOM TEMPERATURE)	: 20°C
(RELATIVE HUMIDITY)	: %50
EN 10077-2	

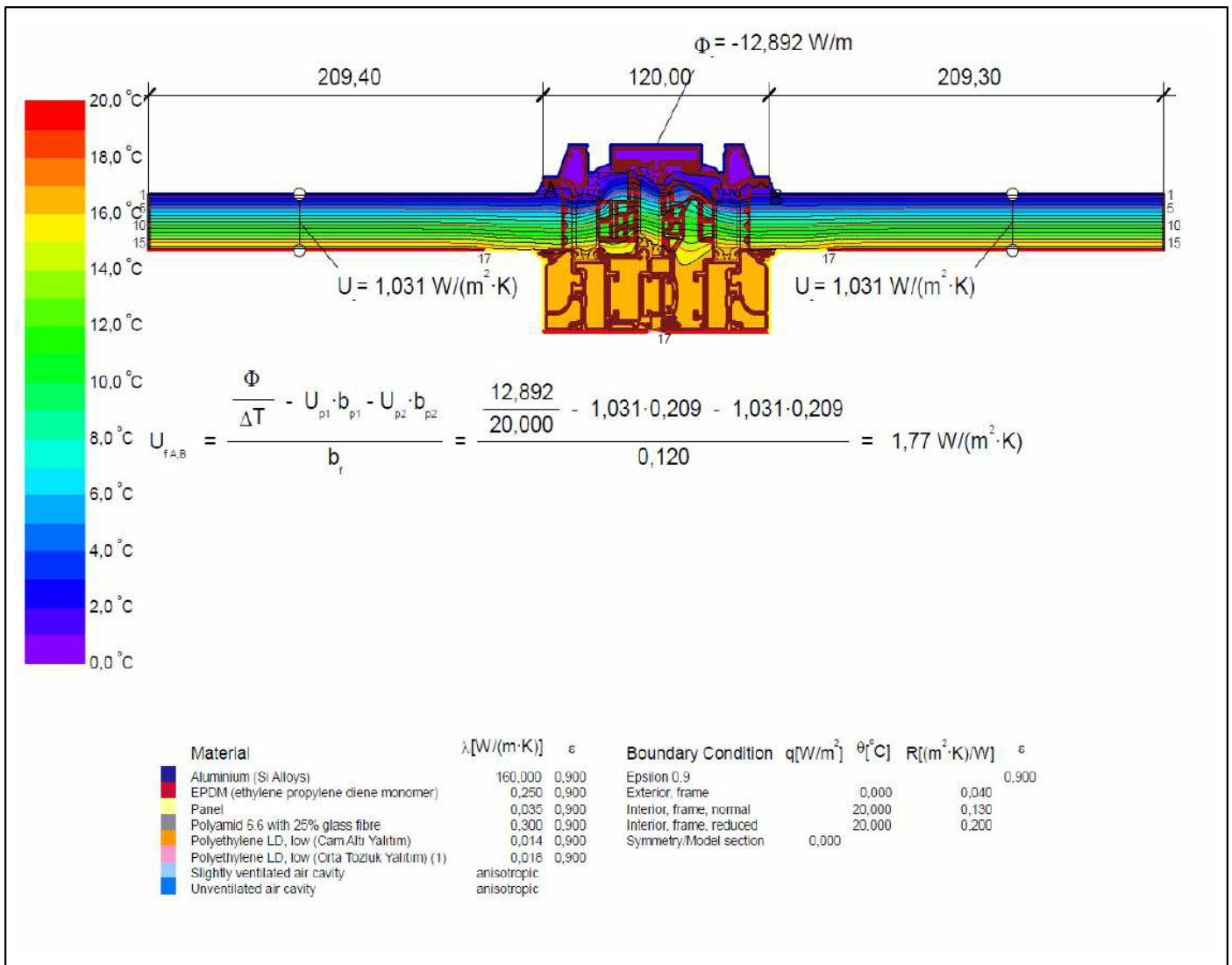

AS EN 10077-2 standard , room temperature is 20°C ,outer temperature is 0 C and relative humidity is 50%.

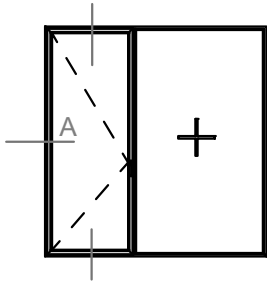

INWARD OPENING STEP DOOR

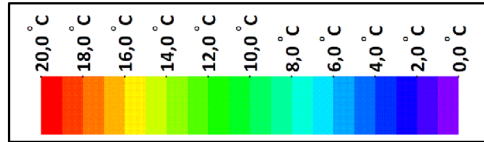

THERMAL CALCULATION CONDITIONS	
(OUTER TEMPERATURE)	: 0°C
(ROOM TEMPERATURE)	: 20°C
(RELATIVE HUMIDITY)	: %50
EN 10077-2	

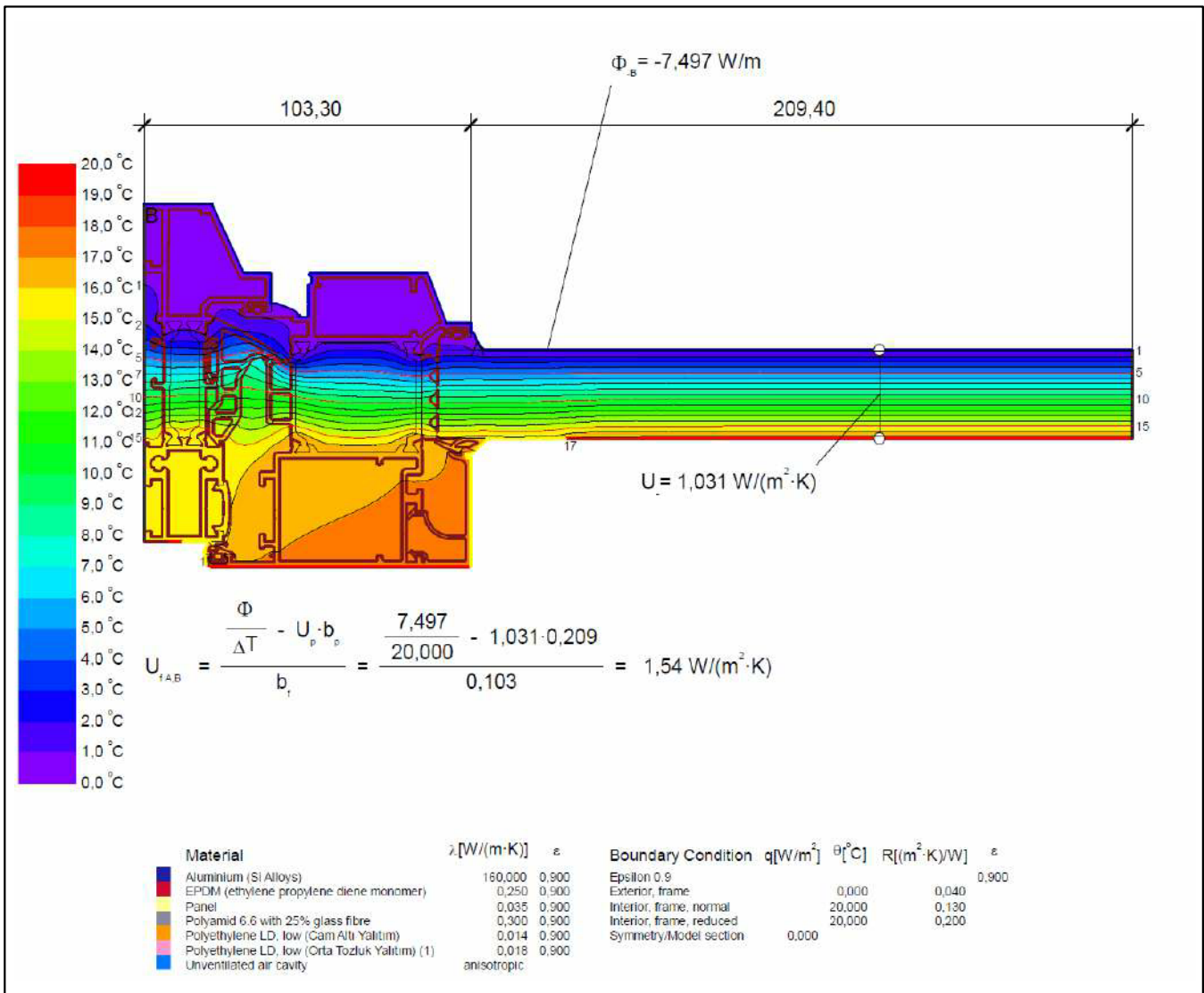

AS EN 10077-2 standard , room temperature is 20°C ,outer temperature is 0 C and relative humidity is 50%.

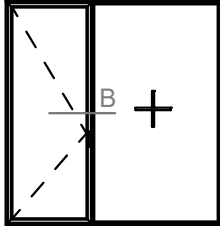

INWARD OPENING STEP DOOR

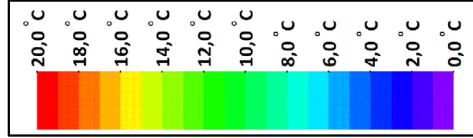

THERMAL CALCULATION CONDITIONS	
(OUTER TEMPERATURE)	: 0°C
(ROOM TEMPERATURE)	: 20°C
(RELATICE HUMIDITY)	: %50
EN 10077-2	

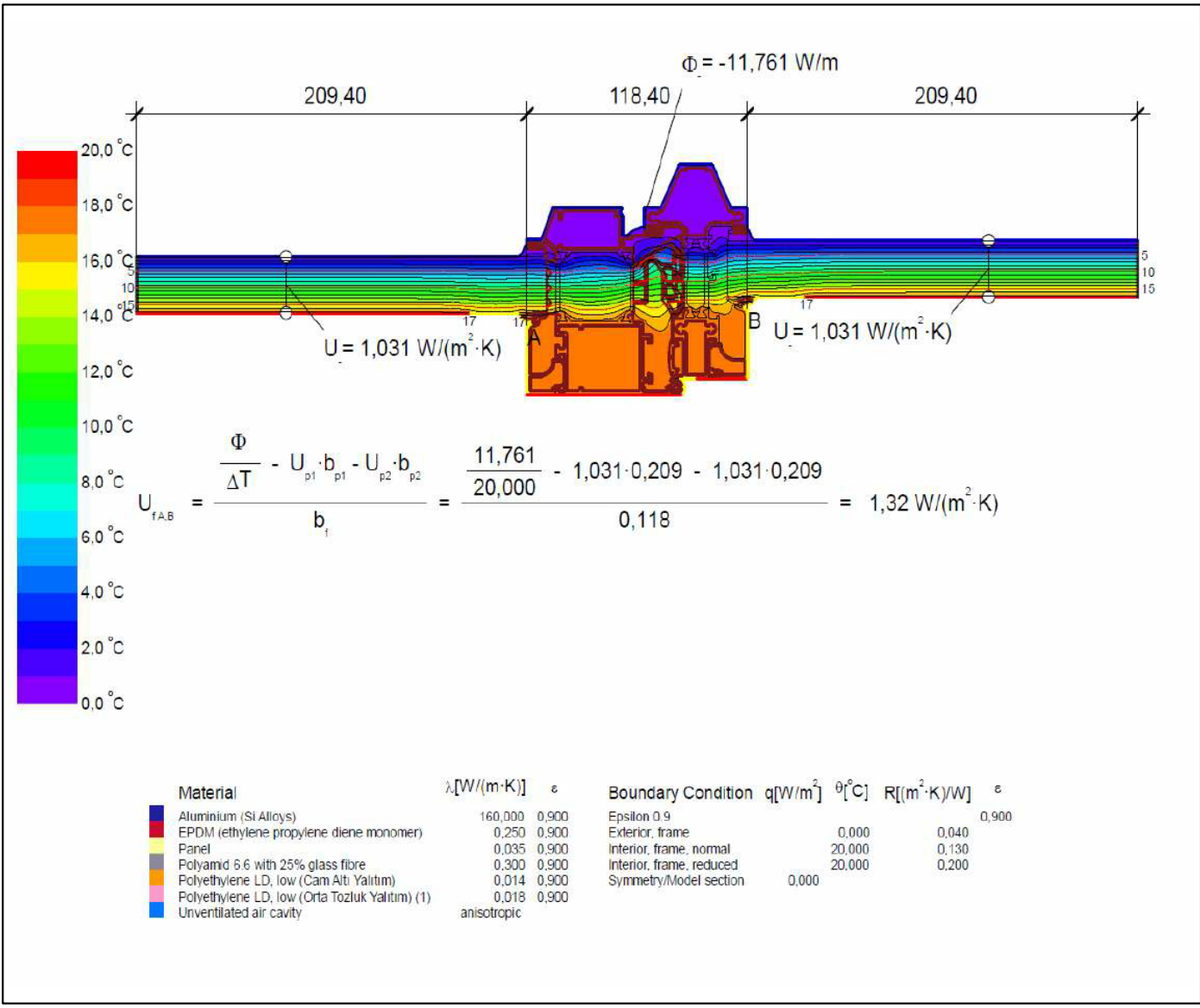

AS EN 10077-2 standard , room temperature is 20°C ,outer temprature is 0 C and relative humidity is 50%.

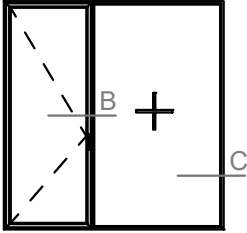

INWARD OPENING STEP DOOR

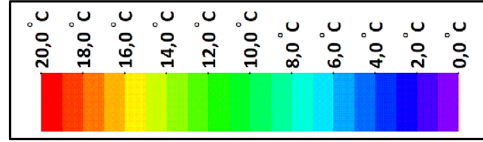

THERMAL CALCULATION CONDITIONS

(OUTER TEMPERATURE) : 0°C

(ROOM TEMPERATURE) : 20°C

(RELATIVE HUMIDITY) : %50

EN 10077-2

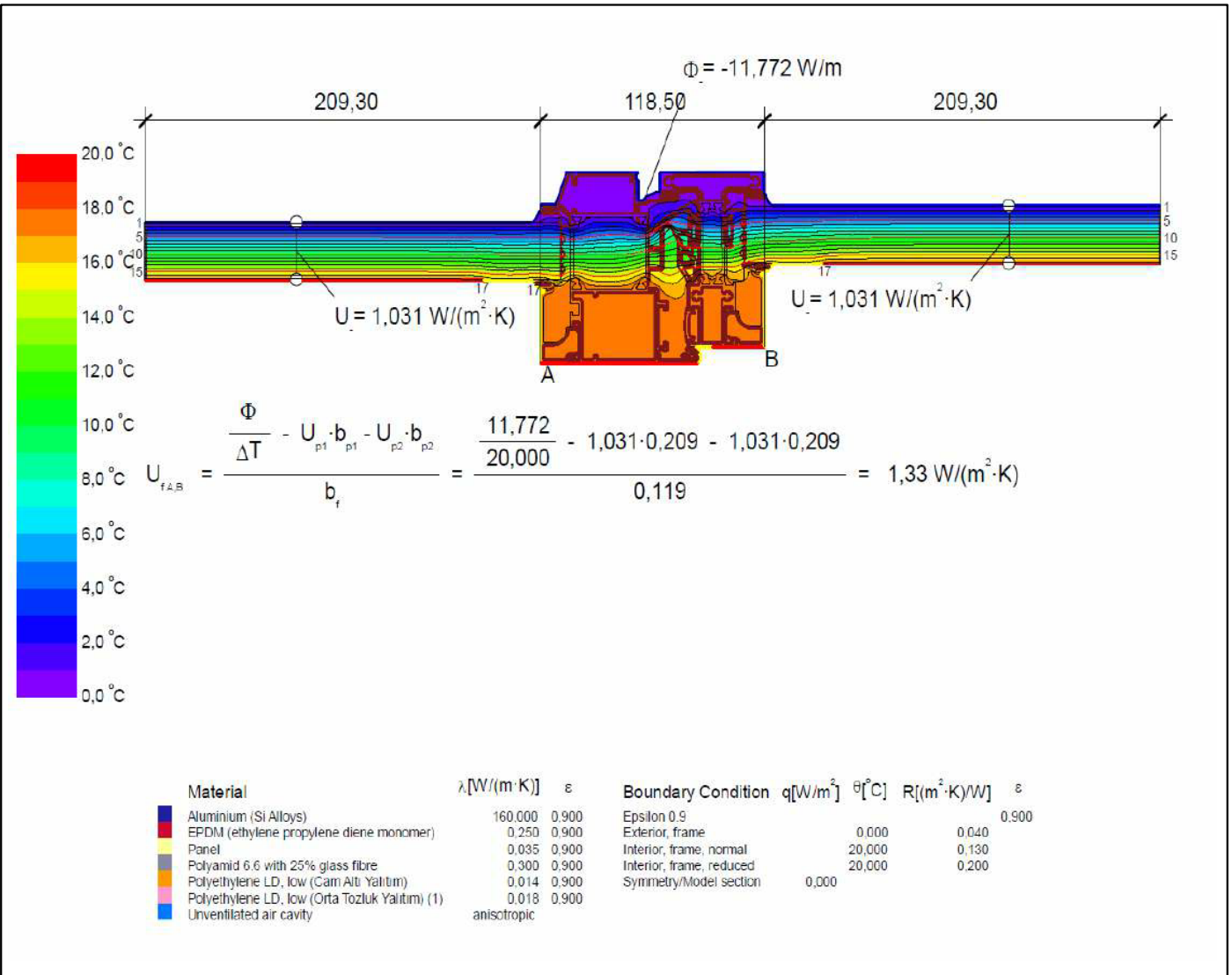

AS EN 10077-2 standard , room temperature is 20°C ,outer temperature is 0 C and relative humidity is 50%.

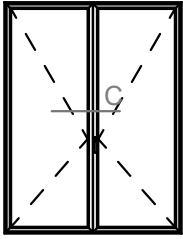

INWARD OPENING STEP DOOR

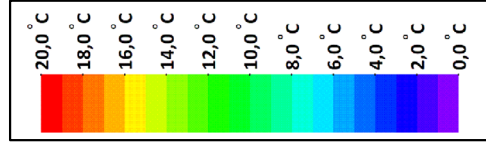

THERMAL CALCULATION CONDITIONS

(OUTER TEMPERATURE) : 0°C

(ROOM TEMPERATURE) : 20°C

(RELATICE HUMIDITY) : %50

EN 10077-2

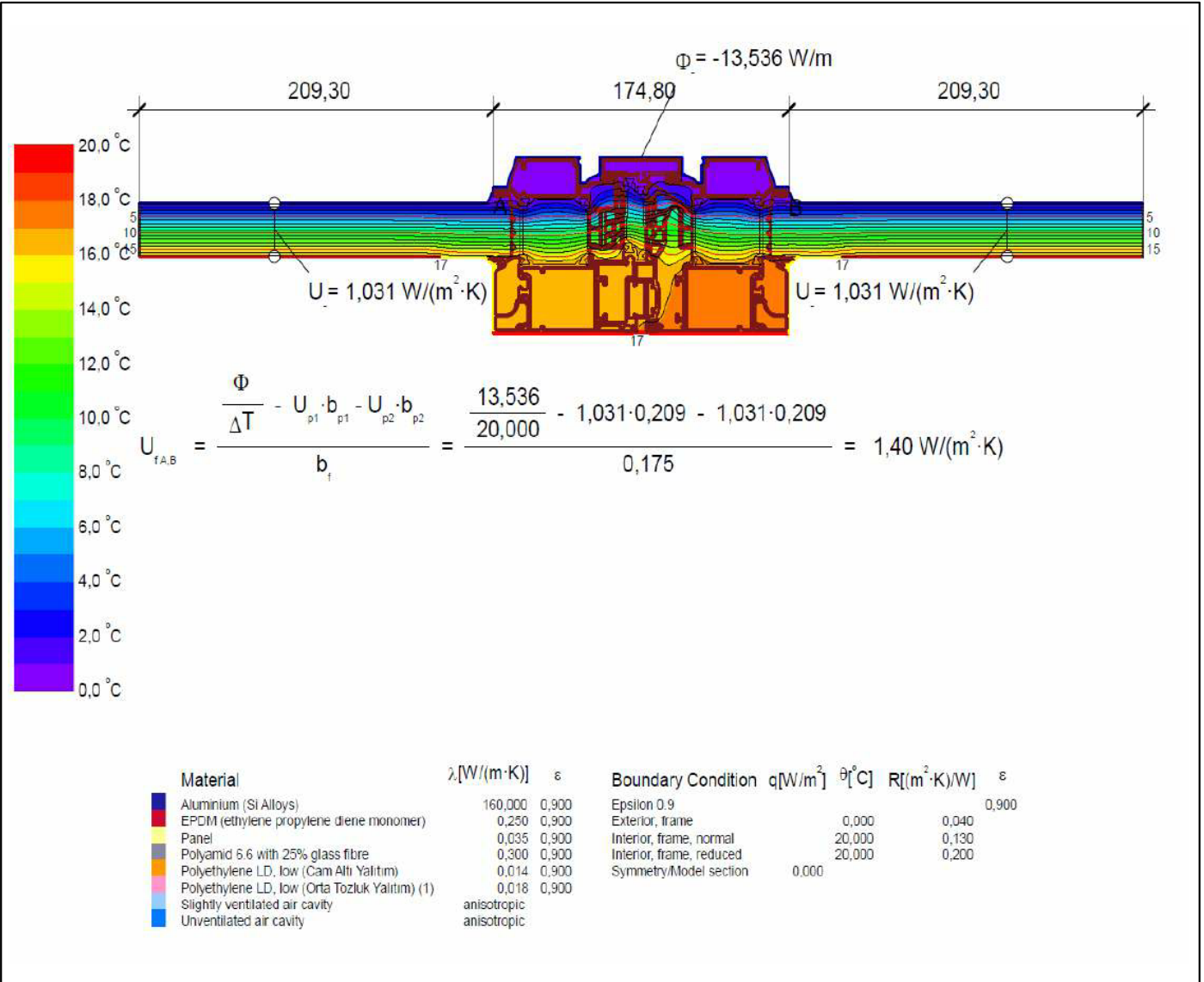

AS EN 10077-2 standard , room temperature is 20°C ,outer temperature is 0 C and relative humidity is 50%.

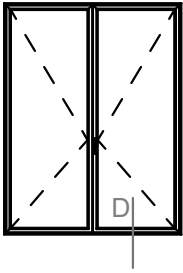

INWARD OPENING STEP DOOR

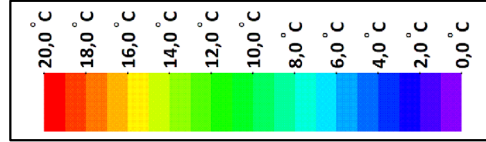





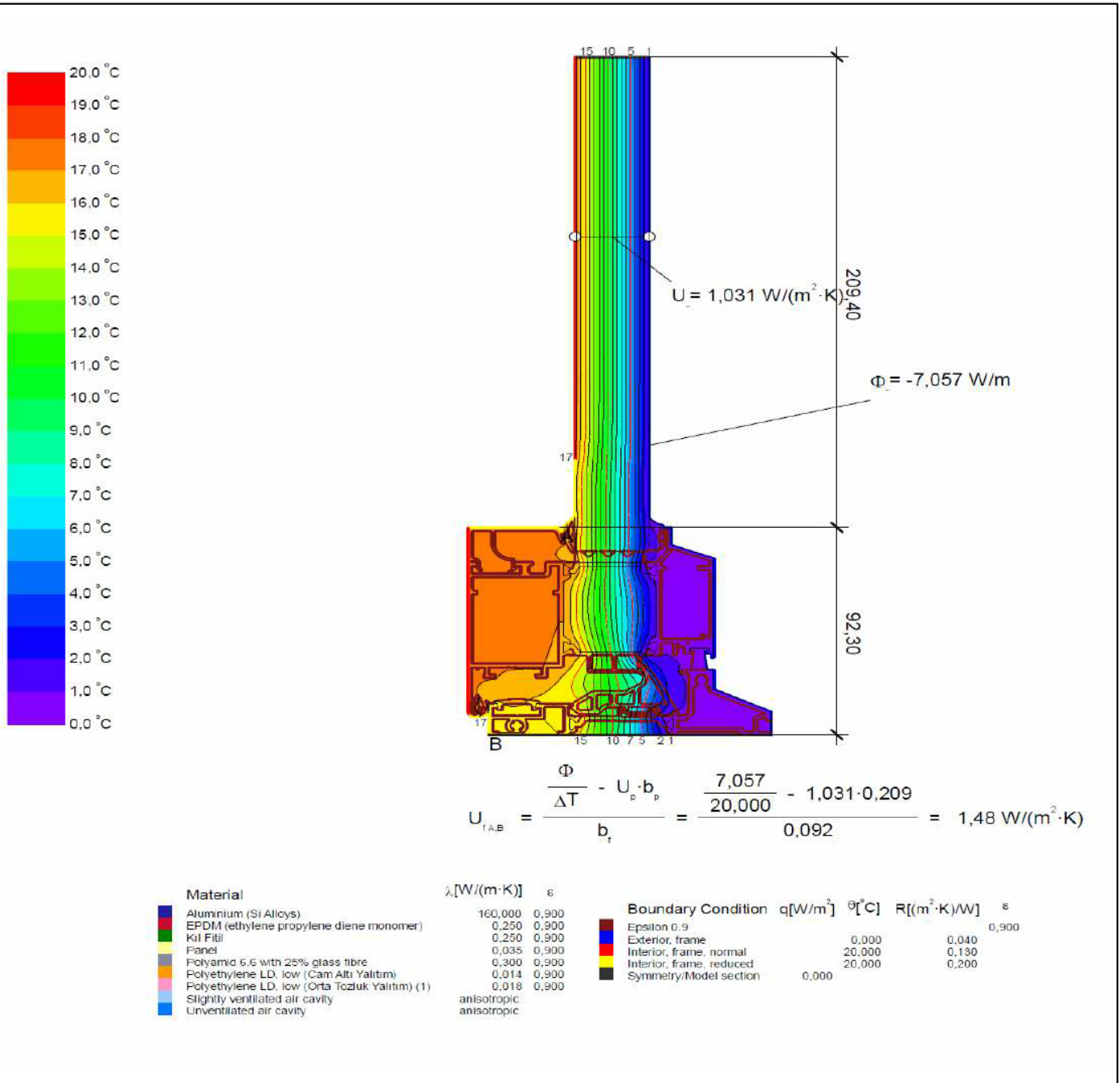

THERMAL CALCULATION CONDITIONS

(OUTER TEMPERATURE) : 0°C
 (ROOM TEMPERATURE) : 20°C
 (RELATICE HUMIDITY) : %50

EN 10077-2

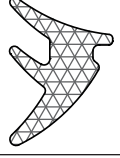
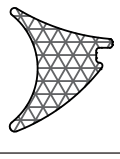
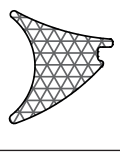

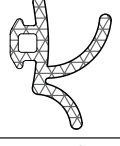

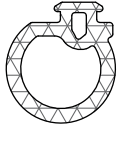
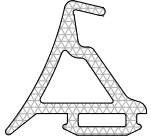

AS EN 10077-2 standard , room temperature is 20°C ,outer temprature is 0 C and relative humidity is 50%.

Shape	Codee	Description
	G1002	inner glazing gasket (2mm) EPDM
	G1003	inner glazing gasket (3mm) EPDM
	G1004	inner glazing gasket (4mm) EPDM
	G1005	inner glazing gasket (5mm) EPDM
	G1006	inner glazing gasket (6mm) EPDM
	G1007	inner glazing gasket (7mm) EPDM
	mo68	outer glazing gasket EPDM
	mo60	sash gasket EPDM
	G300-157	frame gasket EPDM
	G300-158	raindrop gasket EPDM
	G300-155	gasket for open joint EPDM

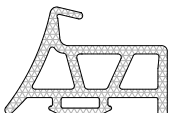
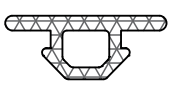
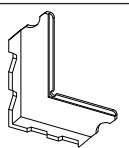
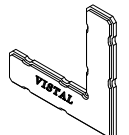
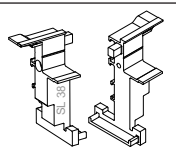
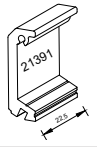
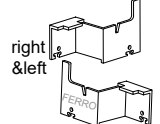
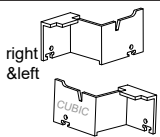
CS59
CS68
CS68F
CS68H
CS77
CS77H
MASTERLINE8
SLIMLINE38
S560
S560 Mono
S560 Threshold

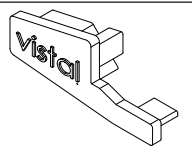
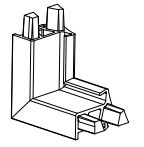
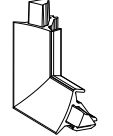
CS59
CS68
CS68F
CS68H
CS77
CS77H
MASTERLINE8
SLIMLINE38
S560
S560 Mono
S560 Threshold

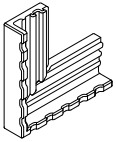
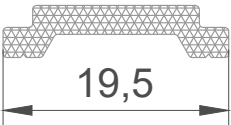
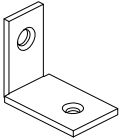
Shape	Codee	Description
	G300-156	gasket for open joint EPDM
	G300-167	bottom rail gasket EPDM
	MO20	corner alignment PVC
	560-1001	corner alignment PVC
	2000-185	adapter cover POLIAMID
	2000-105	T joint ALUMINIUM
	2000-186	bottom plate caps PVC
	2000-187	bottom plate caps PVC
	2000-101	T profil adapter caps PVC
	2000-102	T profil adapter caps PVC
	2000-113	corner gasket for open joint EPDM
	2000-114	corner gasket for open joint EPDM

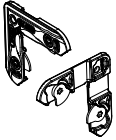
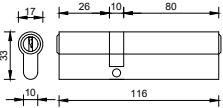
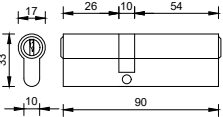
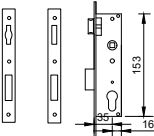
Shape	Codee	Description
	2000-111	corner alignment POLIAMID
	917620	rod profile POLIAMID
	P100	T joint fixing GALVANIZED ¹
	2000-100	T profil adapter caps ALUMINIUM
	2000-108	T joint connection STEEL
	CYLINDER 116	CYLINDER 116
	CYLINDER 90	CYLINDER 90
	mourtise lock	mourtise lock with cylinder or roller

CS59

CS68

CS68F

CS68H

CS77

CS77H

MASTERLINE8

SLIMLINE38

S560

S560 Mono

S560 Threshold

CS59
CS68
CS68F
CS68H
CS77
CS77H
MASTERLINE8
SLIMLINE38
S560
S560 Mono
S560 Threshold

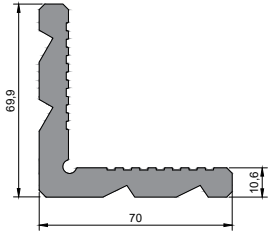
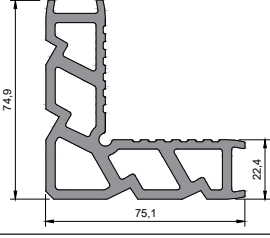
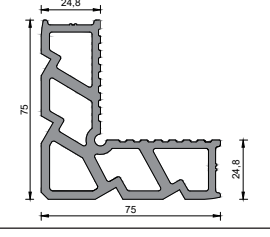
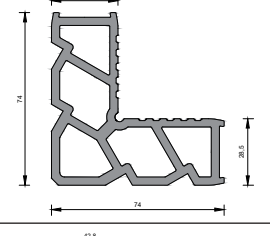
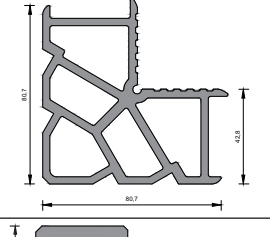
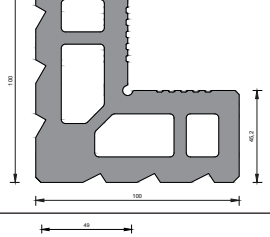
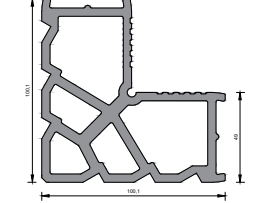
Shape	Codee	Description
	C10.6	corner cleat 3.43 kg/m
	C22.4	corner cleat 3.67 kg/m
	C24.8	corner cleat 3.59 kg/m
	C28.5	corner cleat 3.75 kg/m
	C42.8	corner cleat 4.59 kg/m
	C45.2	corner cleat 12.95 kg/m
	C49	corner cleat 7.23 kg/m

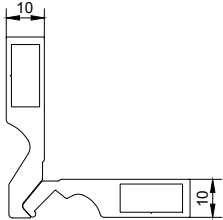
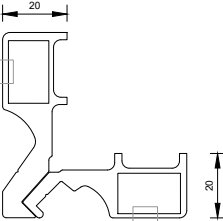
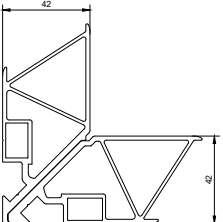
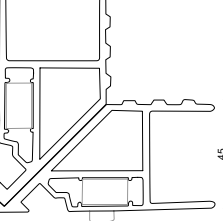
Shape	Codee	Description
	PC B10	corner cleat (punch)
	PC B20	corner cleat (punch)
	PC B42	corner cleat (punch)
	PC B45	corner cleat (punch)

CS59

CS68

CS68F

CS68H

CS77

CS77H

MASTERLINE8

SLIMLINE38

S560

S560 Mono

S560 Threshold

CODE	WEIGHT(kg/m)	Ix cm ⁴	Iy cm ⁴
3831-3800	1.53	5.57	56.66
3830-38104	1.75	13.22	65.52

3831-3800

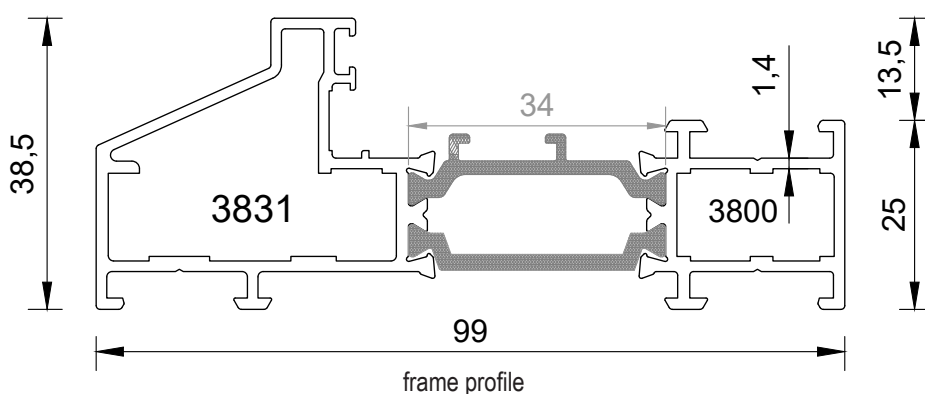

3830-38104

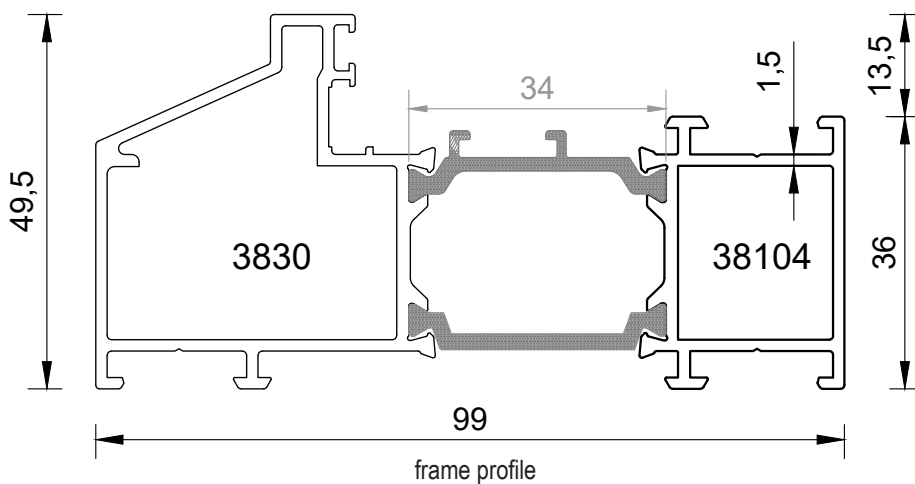

profile	corner cleat	shape	cutting size	punch corner	shape	leinght	button length
3831-3800	C10.6		38.2 mm	PC B10		37.7 mm	9 mm
	C10.6		19.7 mm	PC B10		19.2 mm	
3830-38104	C22.4		38.2 mm	PC B10		37.7 mm	9 mm
	C22.4		19.6 mm	PC B22		19 mm	

scale1:1





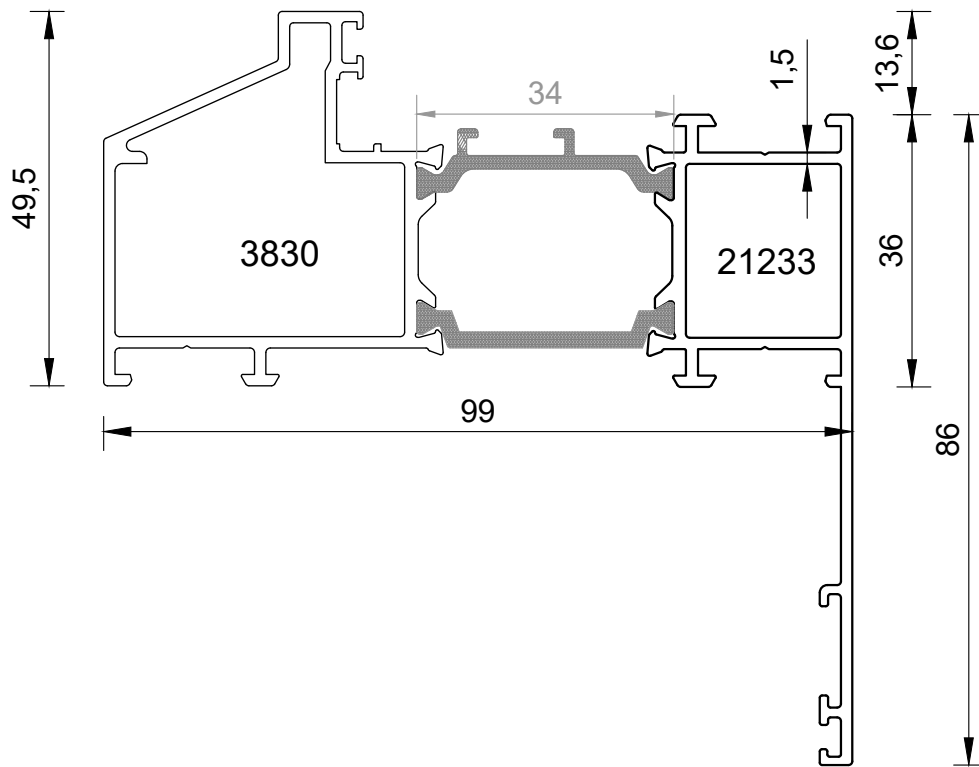

CODE	WEIGHT(kg/m)	lx cm ⁴	ly cm ⁴
3830-21233	2	-	-

3830-21233



frame profile

scale1:1

profile	corner cleat	shape	cutting size	punch corner	shape	leight	
3830-21233	C22.4		38.2 mm 	PC B10		37.7 mm	9 mm
	C22.4		19.6 mm 	PC B22		19 mm	

CODE	WEIGHT(kg/m)	Ix cm ⁴	Iy cm ⁴
3810-3835	1.885	19.46	52.51

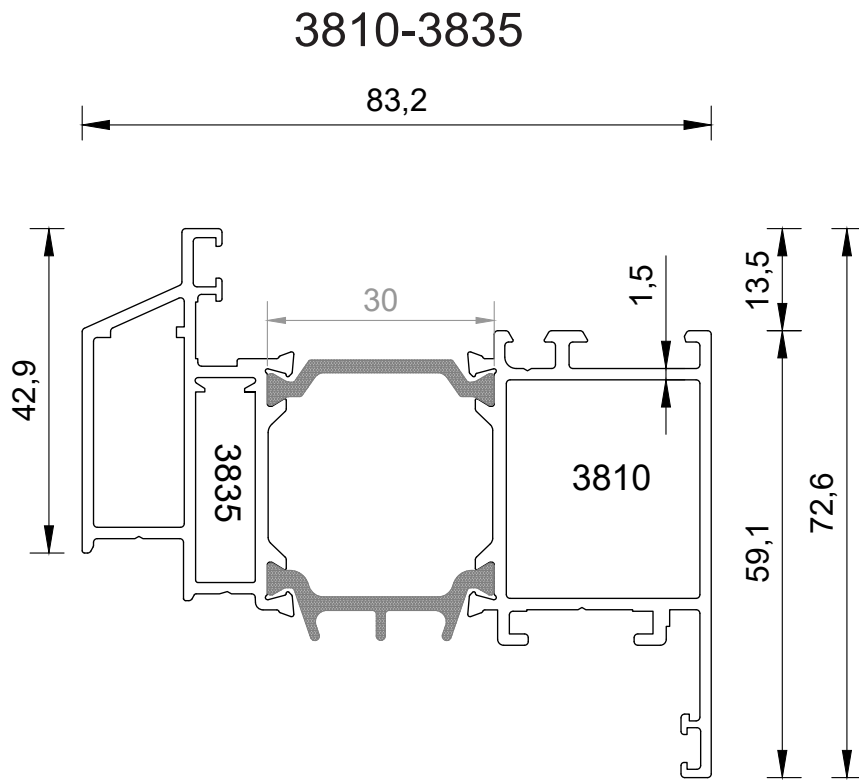

sash profile



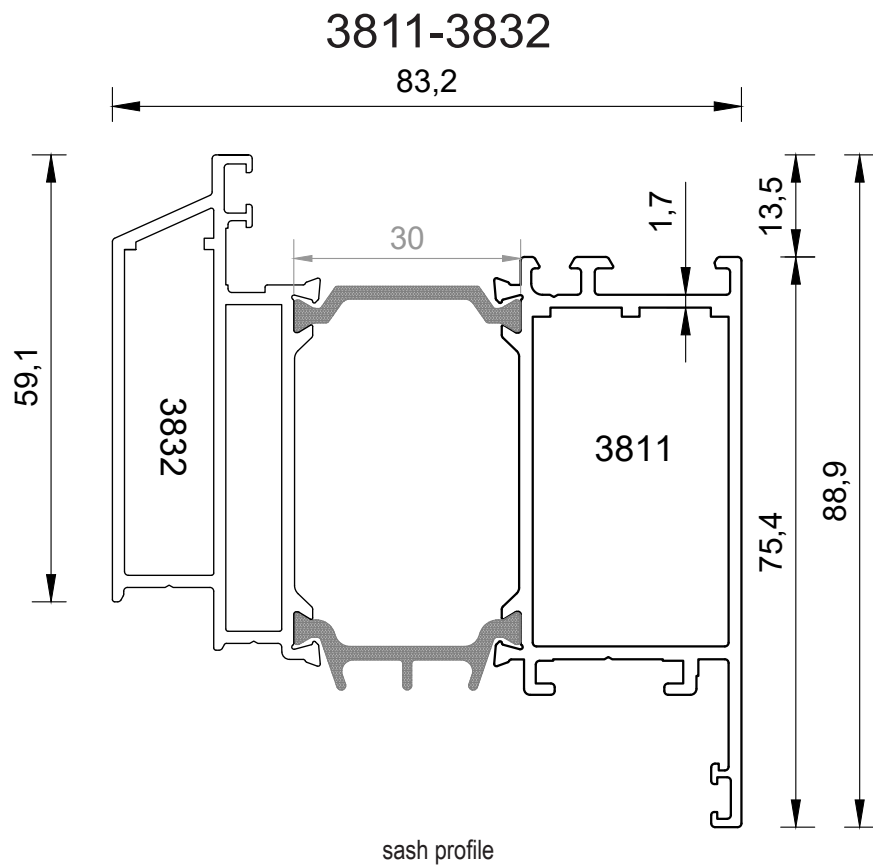

scale 1:1

profile	corner cleat	shape	cutting size	punch corner	shape	leinght	button length
3810-3835	C24.8		11.6 mm	PC B28		25 mm	15 mm
	C24.8		7.3 mm				
	C28.5		25.7 mm				

CODE	WEIGHT(kg/m)	Ix cm ⁴	Iy cm ⁴
3811-3832	2.383	43.07	66.29



scale 1:1

profile	corner cleat	shape	cutting size	punch corner	shape	leinght	button length
3811-3832	C42.8		11.4 mm 	PC B42		25 mm	15 mm
	C42.8		7 mm 				
	C42.8		25.5 mm 				

CODE	WEIGHT(kg/m)	Ix cm ⁴	Iy cm ⁴
3843-3844	2.46		

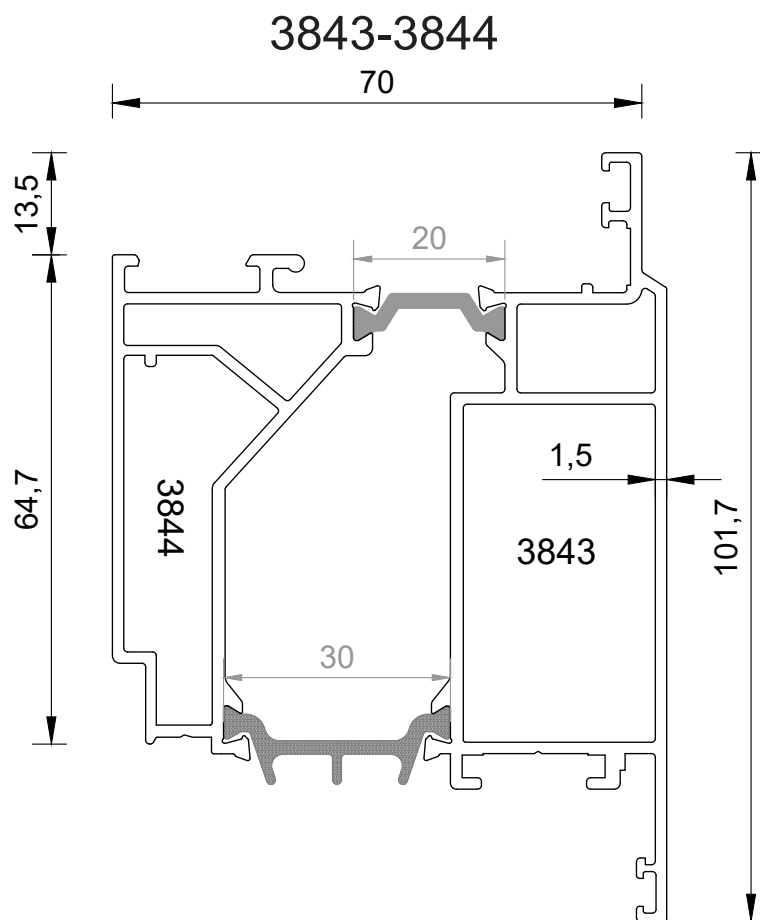

Out ward opening sash profile

scale1:1

profile	corner cleat	shape	cutting size	punch corner	shape	leinght	button length
3843-3844	C45.2		25.6 mm	PC B45		25 mm	15 mm
	C49		6.4 mm				

CODE	WEIGHT(kg/m)	Ix cm ⁴	Iy cm ⁴
3834-38104	2.04	68.84	18.67
3834-21138	2.43	81.28	19.84

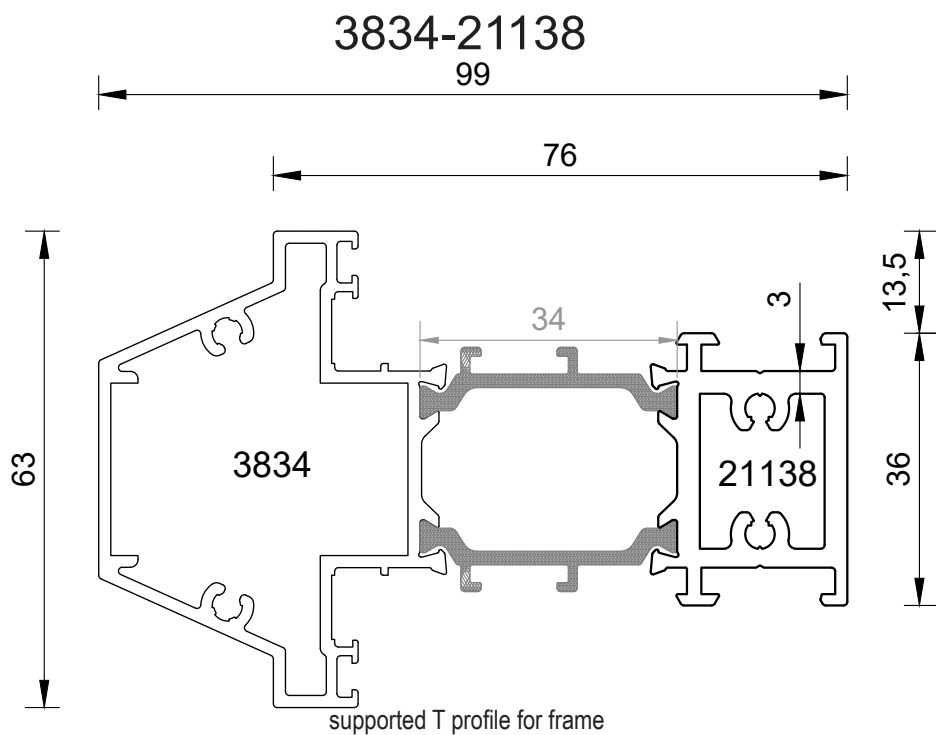
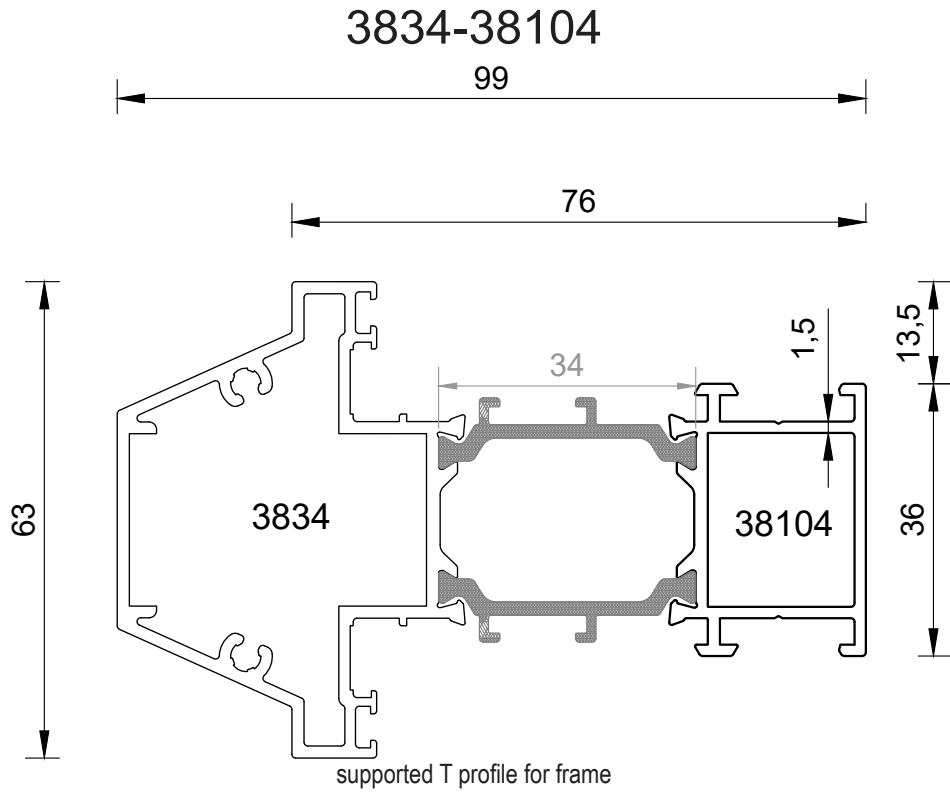

scale 1:1

CS59

CS68

CS68F

CS68H

CS77

CS77H

MASTERLINE8

SLIMLINE38

S560

S560 Mono

S560 Threshold

CODE	WEIGHT(kg/m)	Ix cm ⁴	Iy cm ⁴
3808-3809	1.52	33.72	12.10
3806-38104	1.72	43.52	15.66

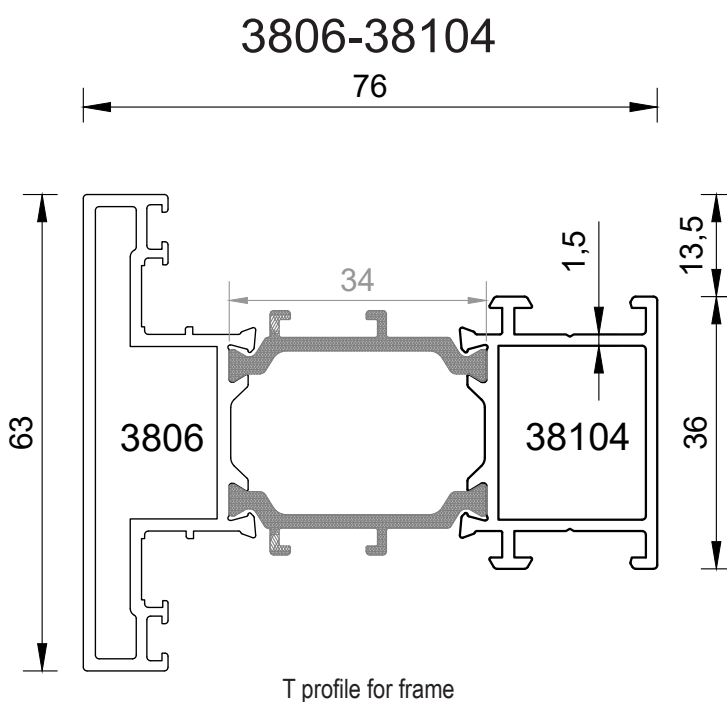
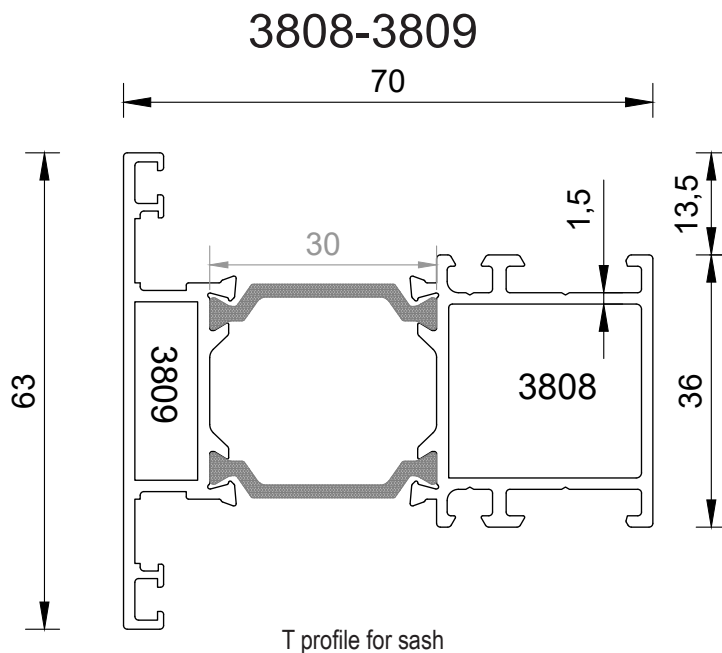

scale 1:1

CODE	WEIGHT(kg/m)	Ix cm ⁴	Iy cm ⁴
3806-21138	2.17	55.96	16.83
21490	0.520		

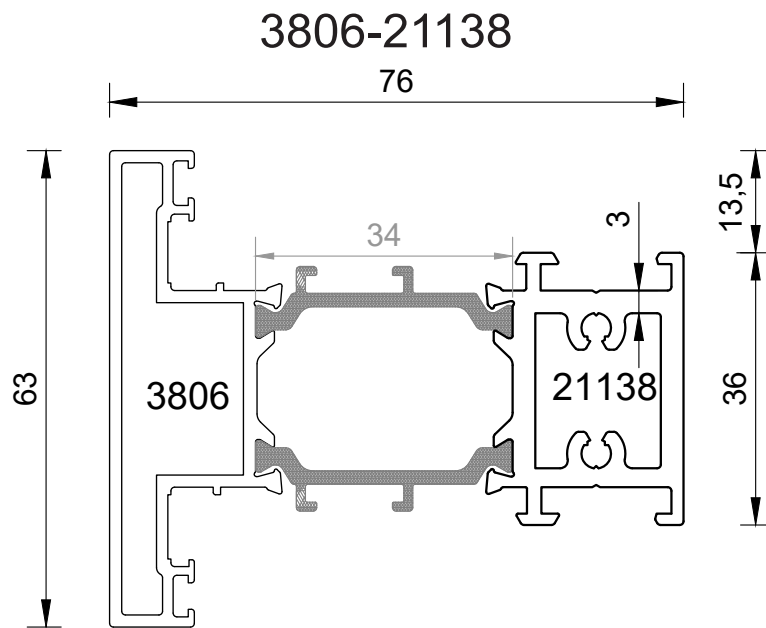

T profile for frame

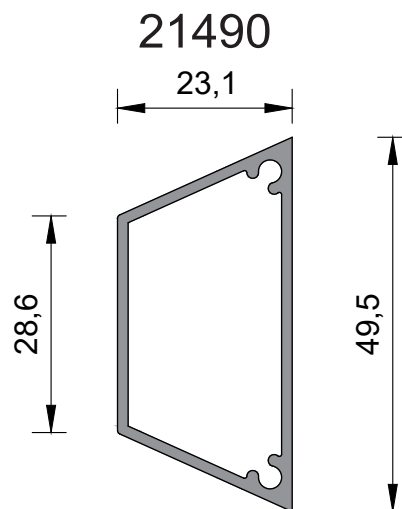

Frame T profile adapter

scale 1:1

CS59

CS68

CS68F

CS68H

CS77

CS77H

MASTERLINE8

SLIMLINE38

S560

S560 Mono

S560 Threshold

CODE	WEIGHT(kg/m)	Ix cm ⁴	Iy cm ⁴
3800-3801	1.345	4.88	33.73
3802-38104	1.555	11.57	39.38

3800-3801

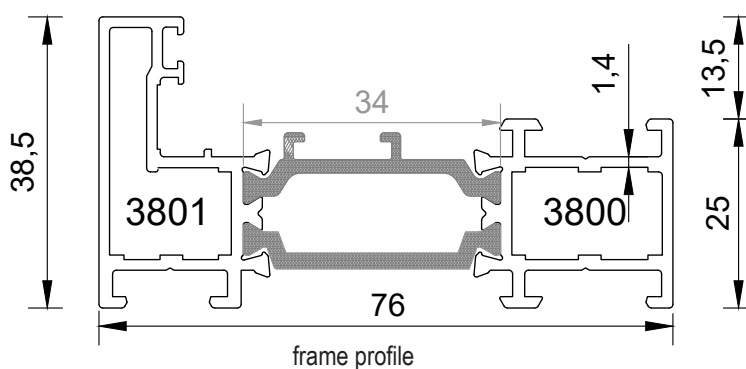

3802-38104

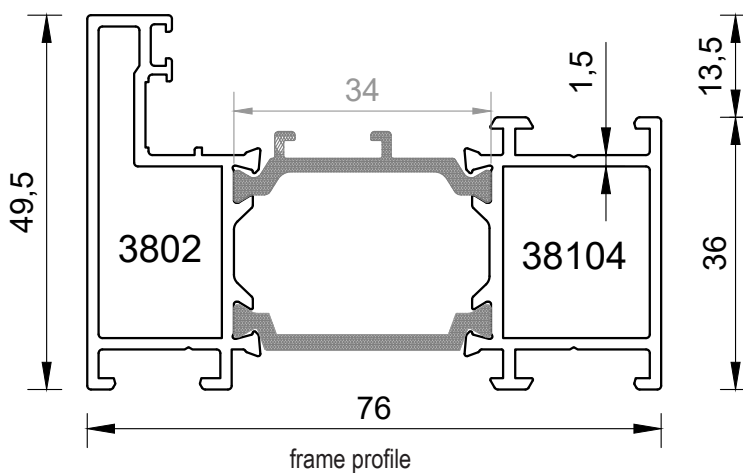





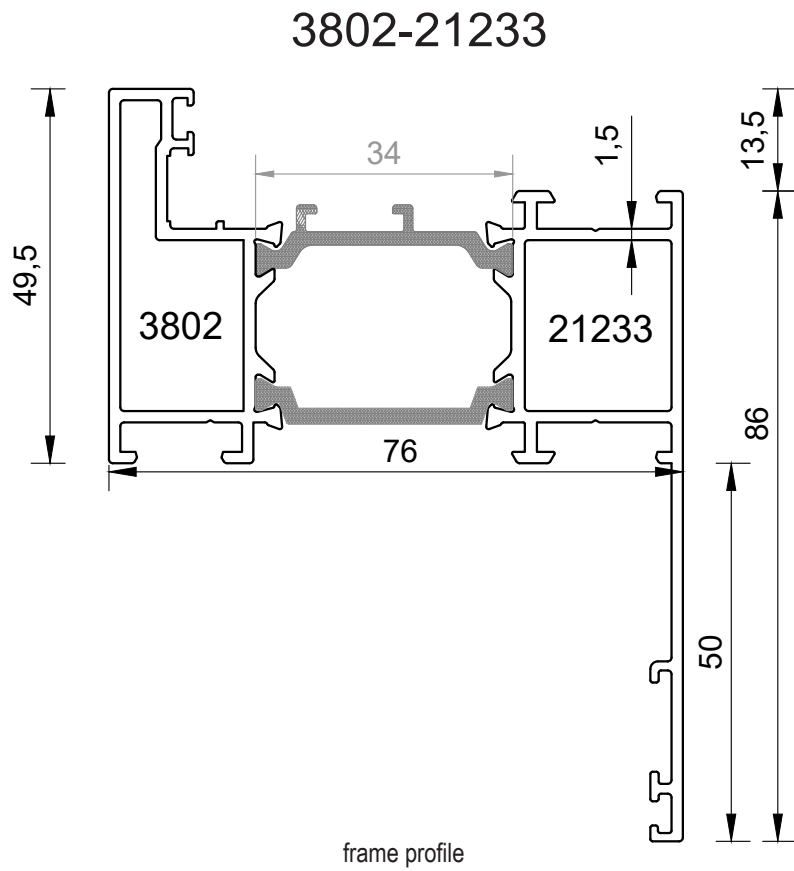

scale1:1

profile	corner cleat	shape	cutting size	punch corner	shape	leinght
3800-3801	C10.6		15.4 mm	PC B10		19.2
	C10.6		19.7 mm			
3802-38104	C22.4		15.3 mm	PC B22		19 mm
	C22.4		19.6 mm			

CODE	WEIGHT(kg/m)	Ix cm ⁴	Iy cm ⁴
3802-21233	1.816		



scale1:1

profile	corner cleat	shape	cutting size	punch corner	shape	leight
3802-21233	C22.4		15.3 mm 	PC B10		37.7 mm
	C22.4		19.6 mm 	PC B22		19 mm

CODE	WEIGHT(kg/m)	Ix cm ⁴	Iy cm ⁴
3803-38106	2.02	35.6	52.25

3803-38106

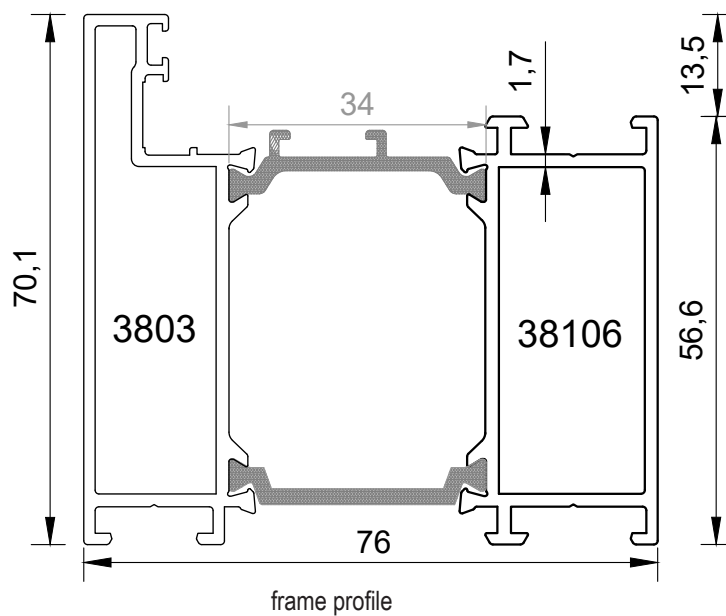





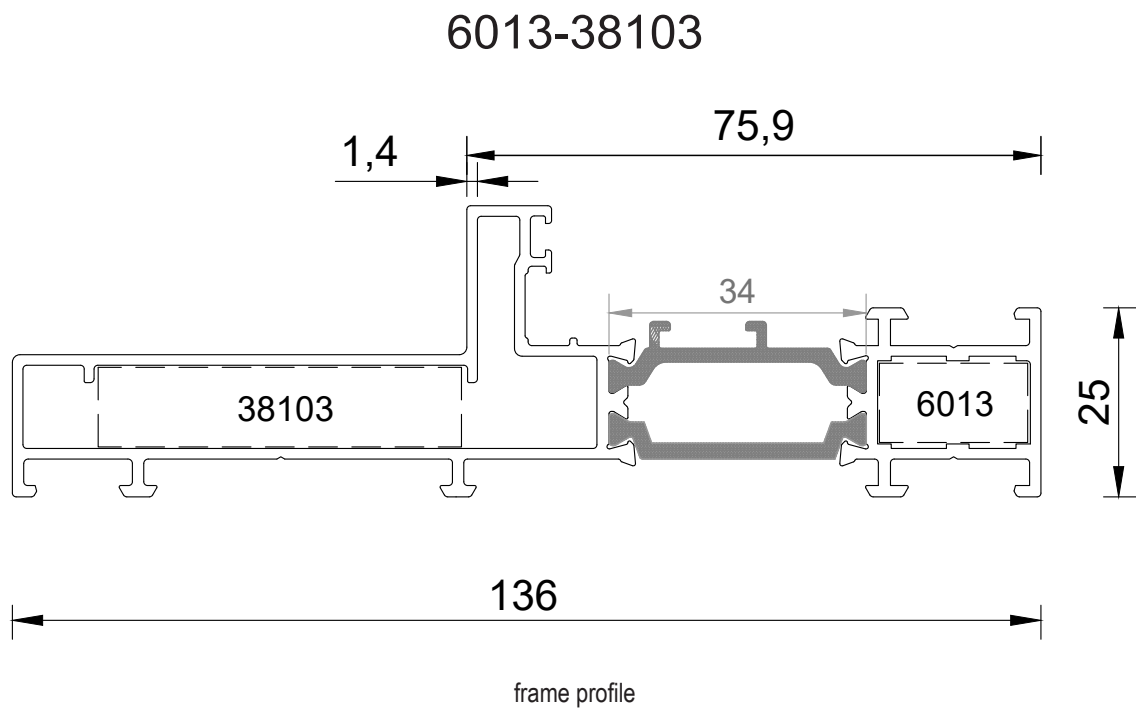

scale 1:1

profile	corner cleat	shape	cutting size	punch corner	shape	leinght
3803-38106	C42.8		15.2 mm	PC B42		19
	C42.8		19.2 mm			

CODE	WEIGHT(kg/m)	Ix cm ⁴	Iy cm ⁴
6013-38103	1.555	11.57	39.38



scale1:1

profile	corner cleat	shape	cutting size	punch corner	shape	leight
6013-38103	C10.6		48.5 mm 	PC B10		48 mm
	C10.6		19.7 mm 	PC B22		19 mm

CODE	WEIGHT(kg/m)	Ix cm ⁴	Iy cm ⁴
3807-3852	1.222	4.58	29.42

3807-3852

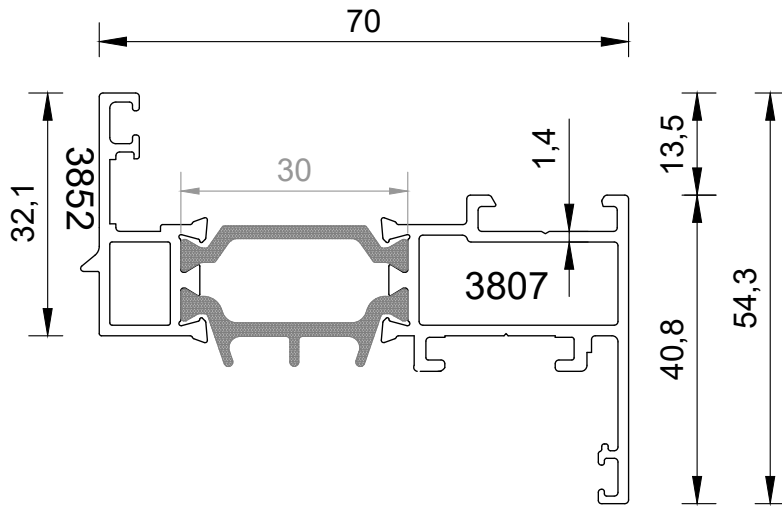

sash profile

scale 1:1

profile	corner cleat	shape	cutting size	punch corner	shape	leinght	button length
3807-3852	C10.6		7.2 mm	PC B10		26	15.2 mm
	C10.6		26.3 mm				

- CS59
- CS68
- CS68F
- CS68H
- CS77
- CS77H
- MASTERLINE8
- SLIMLINE38
- S560
- S560 Mono
- S560 Threshold



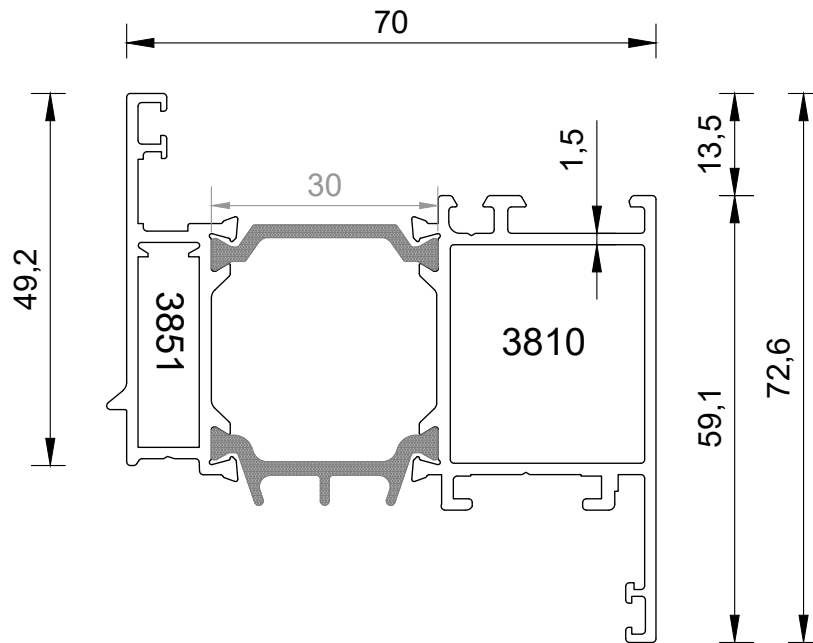

CODE	WEIGHT(kg/m)	Ix cm ⁴	Iy cm ⁴
3810-3851	1.65	17.69	38.79

3810-3851



sash profile

scale1:1

profile	corner cleat	shape	cutting size	punch corner	shape	leinght	button length
3810-3851	C24.8		7.3 mm 				
	C28		25.7 mm 	PC B28		25	15 mm

CODE	WEIGHT(kg/m)	Ix cm ⁴	Iy cm ⁴
3811-3850	2.09	39.33	48.36

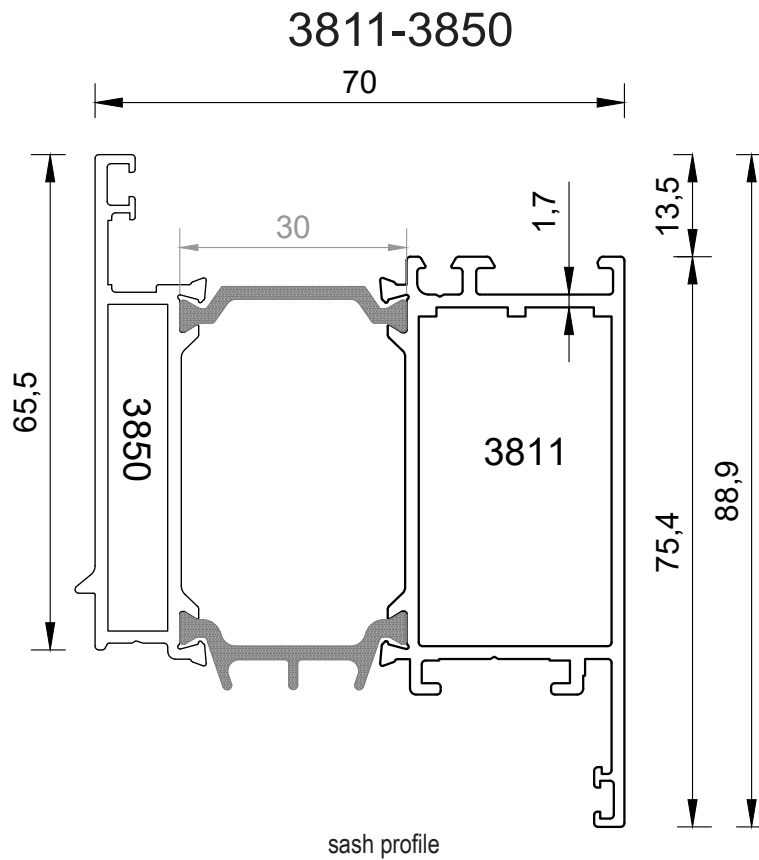

scale 1:1

profile	corner cleat	shape	cutting size	punch corner	shape	leinght	button length
3811-3850	C42.8		7.1 mm	PC B42		25	15 mm
	C42.8		25.5 mm				

- CS59
- CS68
- CS68F
- CS68H
- CS77
- CS77H
- MASTERLINE8
- SLIMLINE38
- S560
- S560 Mono
- S560 Threshold



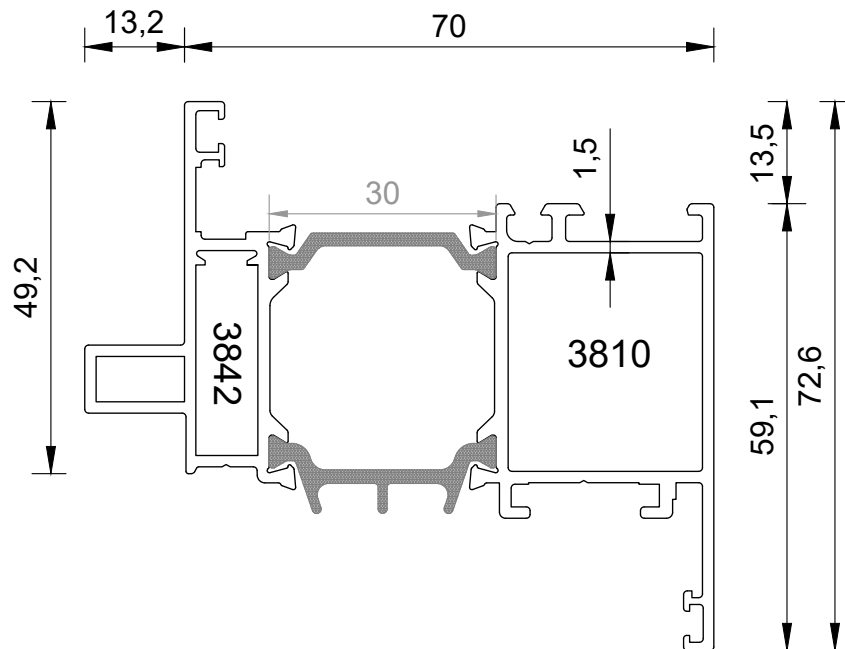

CODE	WEIGHT(kg/m)	Ix cm ⁴	Iy cm ⁴
3810-3842	1.77	17.81	45.98

3810-3842



sash profile

scale1:1

profile	corner cleat	shape	cutting size
3810-3842	C24.8		7.3 mm 
	C28.5		25.7 mm 

CS59

CS68

CS68F

CS68H

CS77

CS77H

MASTERLINE8

SLIMLINE38

S560

S560 Mono

S560 Threshold

CODE	WEIGHT(kg/m)	Ix cm ⁴	Iy cm ⁴
3811-3841	2.225	42.35	61.81

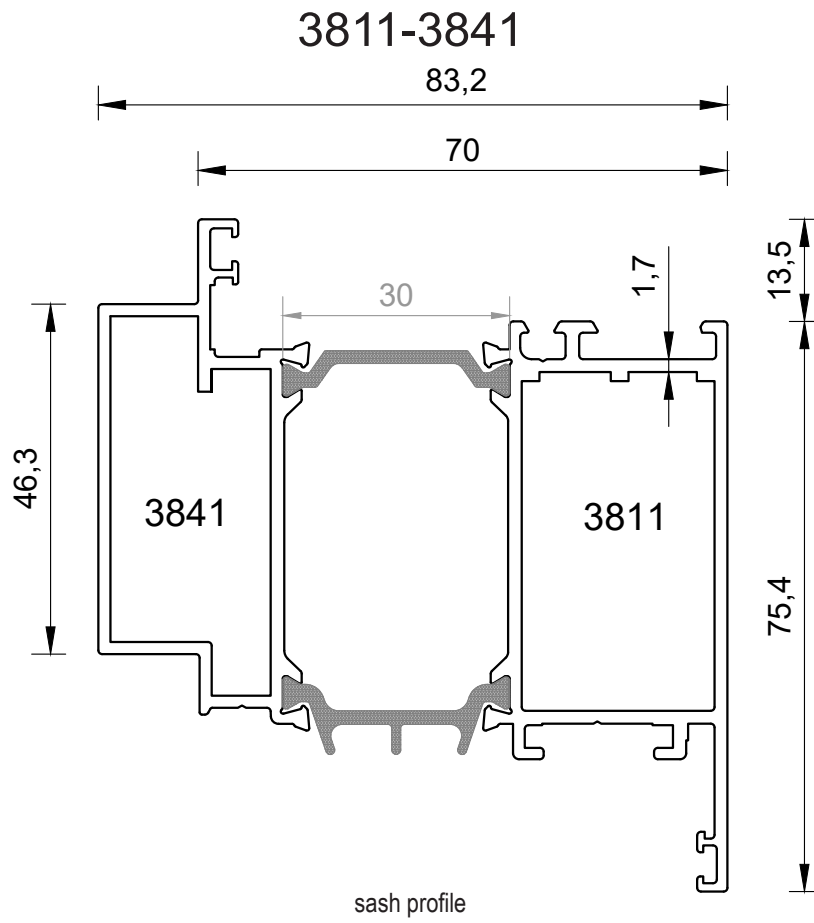

scale 1:1

profile	corner cleat	shape	cutting size	punch corner	shape	leinght	button length
3811-3841	C42.8		11.2 mm	PC B42		25	15 mm
	C42.8		7.1 mm				
	C42.8		25.5 mm				

CODE	WEIGHT(kg/m)	Ix cm ⁴	Iy cm ⁴
3843-3844	1.77	17.81	45.98

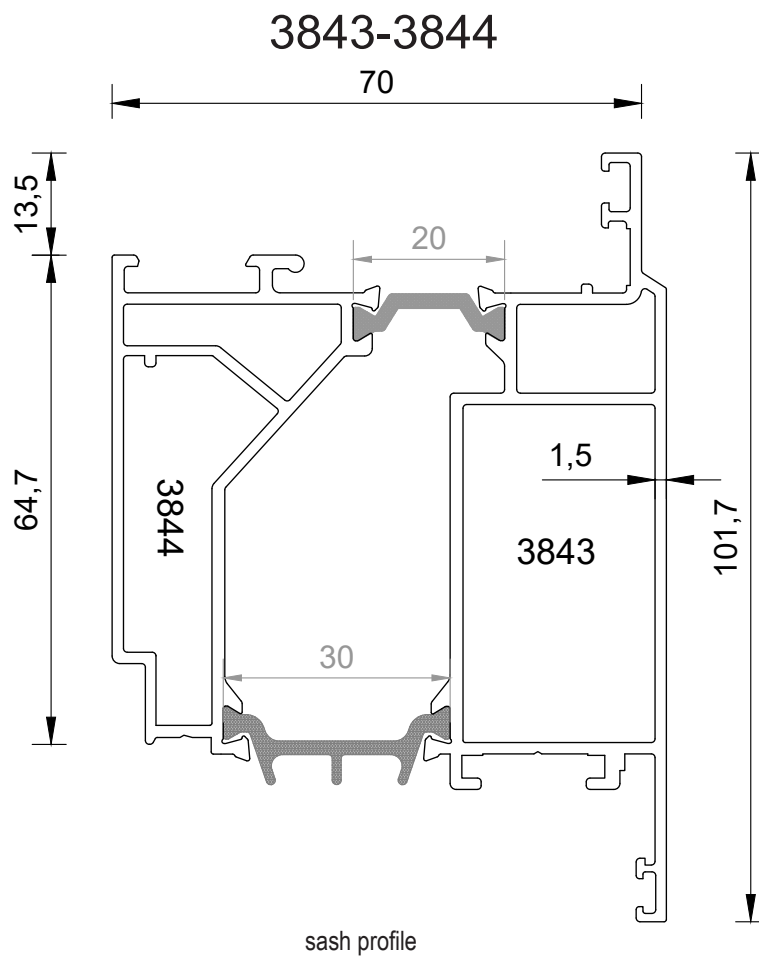

scale1:1

profile	corner cleat	shape	cutting size	punch corner	shape	leinght	button length
3843-3844	C49		6.4 mm	PC B45		25	15 mm
	C45.2		25.6 mm				

CODE	WEIGHT(kg/m)	Ix cm ⁴	Iy cm ⁴
3801-3853	1.284		
3806-38104	1.49	34.82	5.46

3801-3853

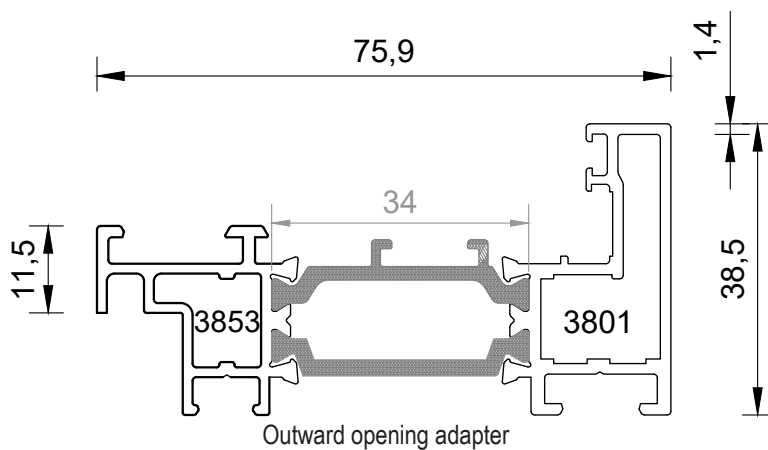

3813-3814

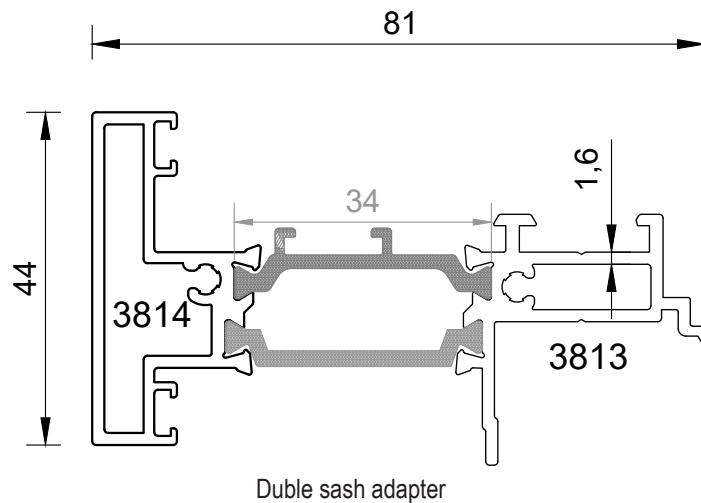

scale1:1

CODE	WEIGHT(kg/m)	Ix cm ⁴	Iy cm ⁴
21462	0.431	-	-
21463	0.441	-	-
21451	0.840	-	-

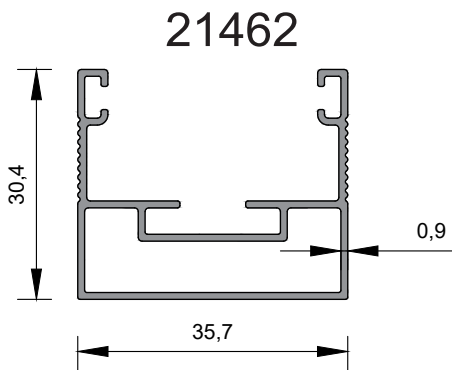

biuaty profil

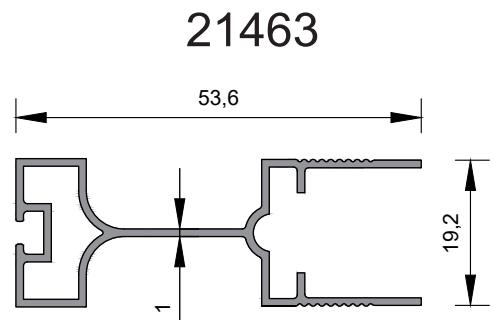

biuaty profil

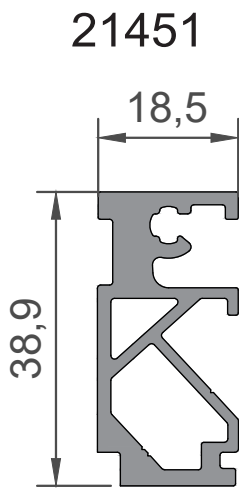

T joint

scale1:1

- CS59
- CS68
- CS68F
- CS68H
- CS77
- CS77H
- MASTERLINE8
- SLIMLINE38
- S560
- S560 Mono
- S560 Threshold

CODE	WEIGHT(kg/m)	Ix cm ⁴	Iy cm ⁴
3819	0.96	10.58	4.64
3820	0.770	9.59	5.64

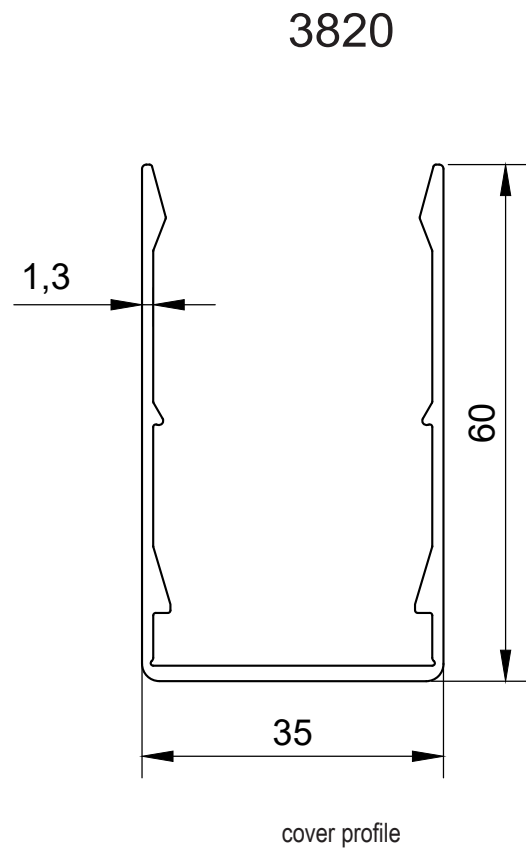
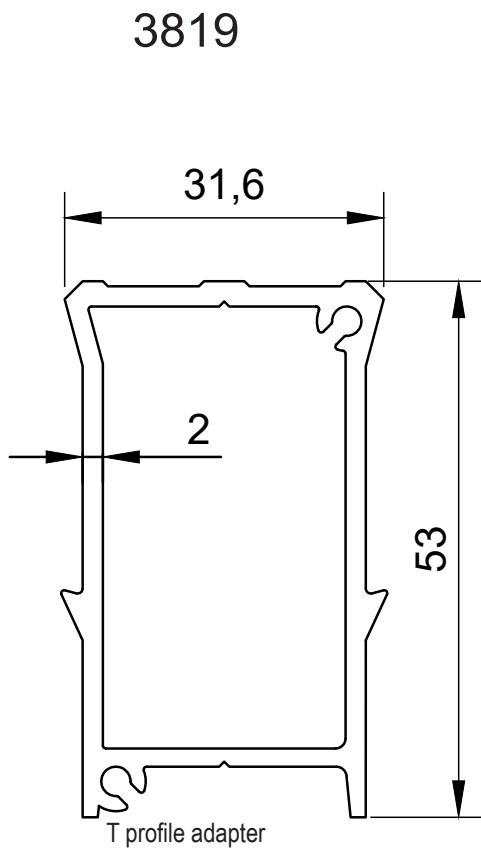

- CS59
- CS68
- CS68F
- CS68H
- CS77
- CS77H
- MASTERLINE8
- SLIMLINE38
- S560
- S560 Mono
- S560 Threshold

CODE	WEIGHT(kg/m)	Ix cm ⁴	Iy cm ⁴
21391	0.950	-	-
21489	1.170	-	-
38100	0.225	-	-
21432	0.393	-	-
21431	0.293	-	-
21418	0.200	-	-

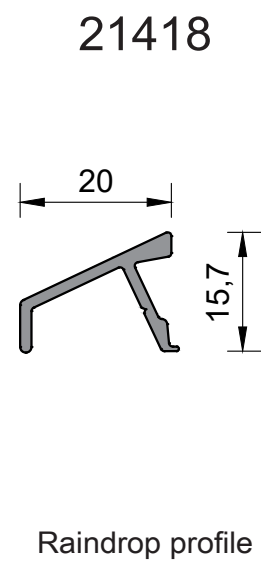
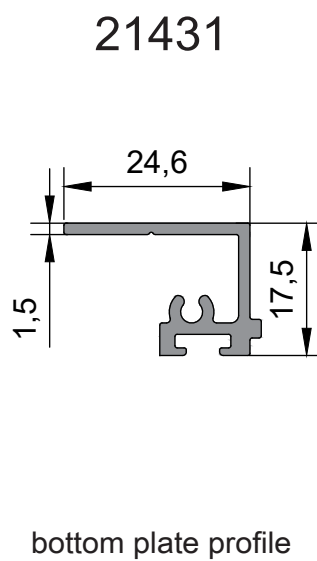
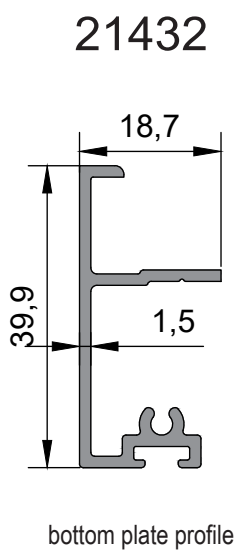
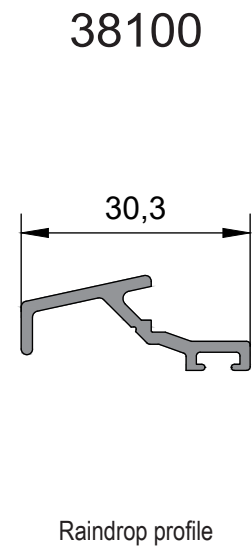
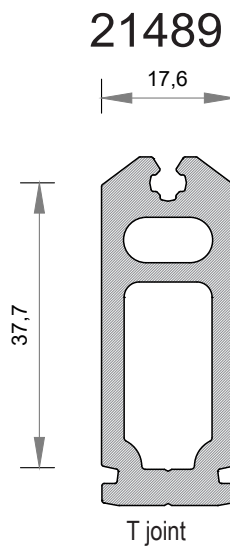
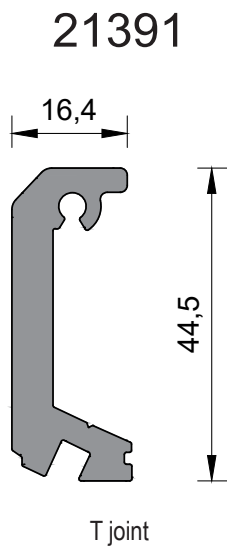

CODE	WEIGHT(kg/m)	Ix cm ⁴	Iy cm ⁴
3826-3827	2.12	54.97	54.91
3824-3825	1.5	31.88	8.36

3826-3827

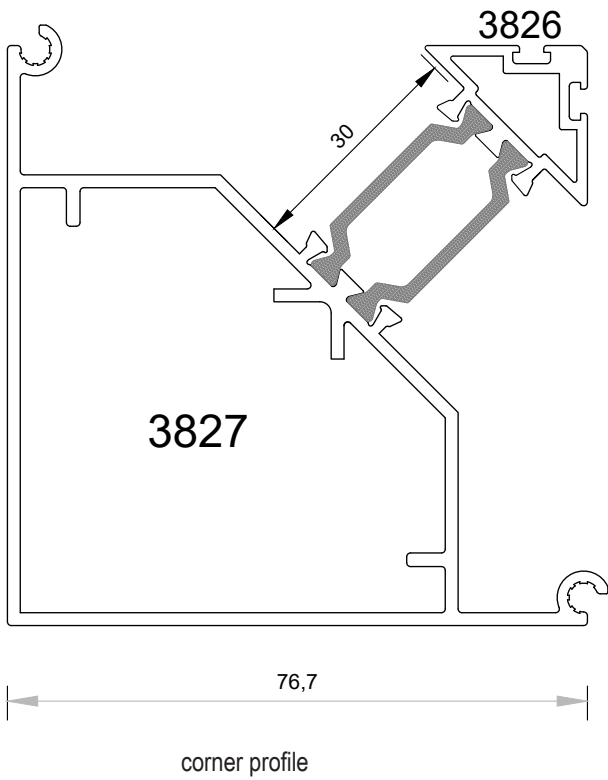

3824-3825

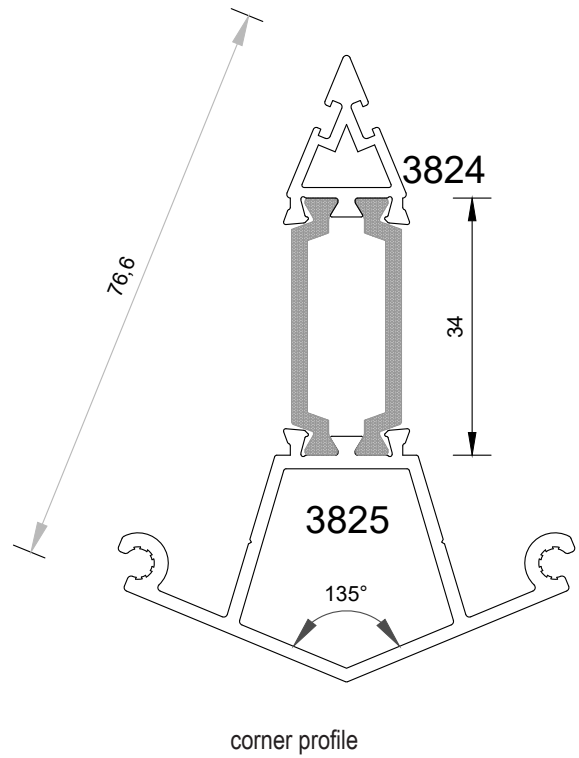

CODE	WEIGHT(kg/m)	Ix cm ⁴	Iy cm ⁴
21152-21152	1.55	6.34	60.94
3854-3854	1.61	13.96	64.19

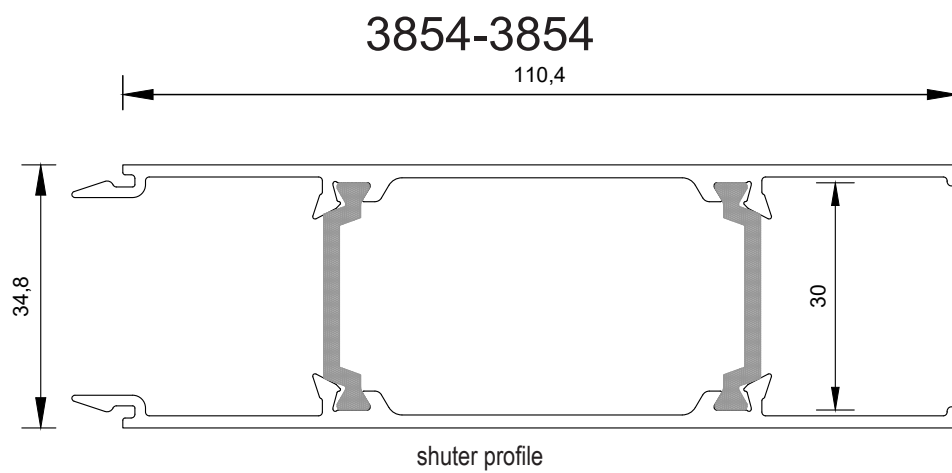
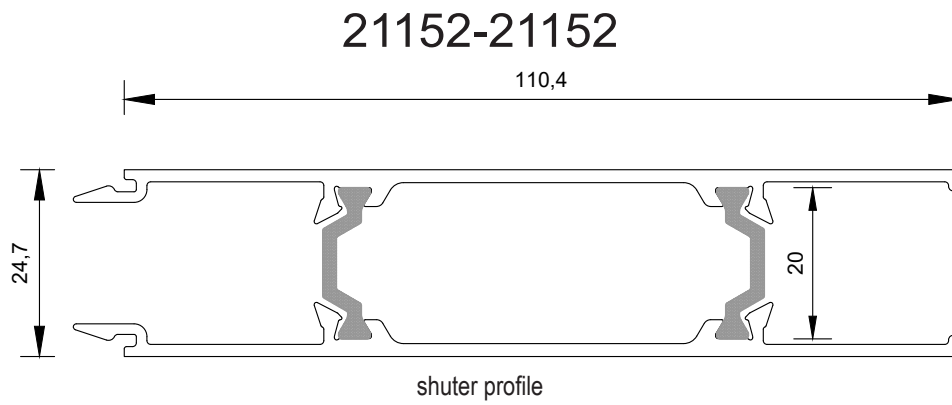

CODE	WEIGHT(kg/m)	Ix cm ⁴	Iy cm ⁴
3829-38101	0.860	-	-
21428	0.52	-	-

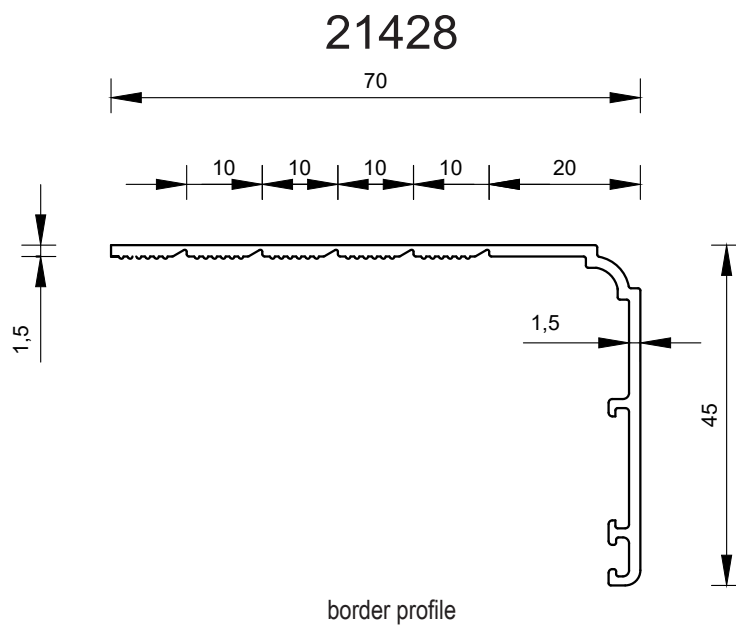
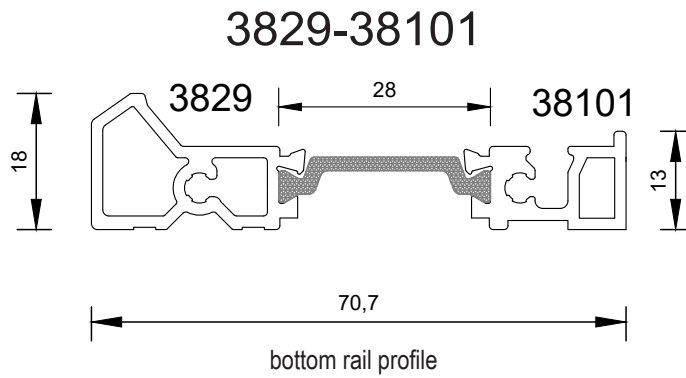

CODE	WEIGHT(kg/m)	Ix cm ⁴	Iy cm ⁴
6015	0.305	-	-
6016	0.257	-	-
6017	0.206	-	-
21429	0.306	-	-

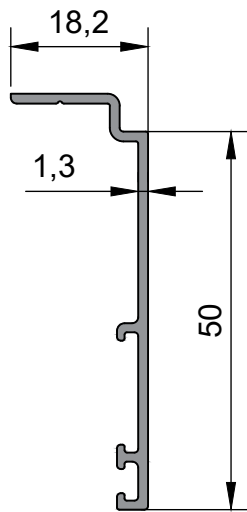
6015

border profile

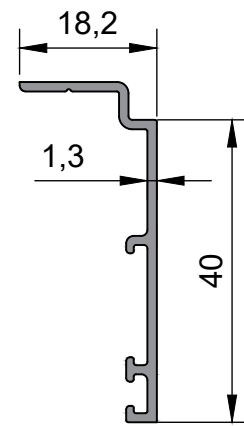
6016

border profile

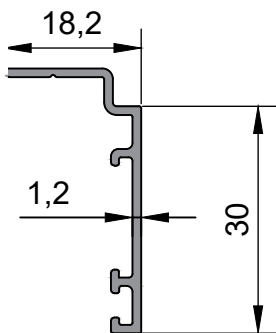
6017

border profile

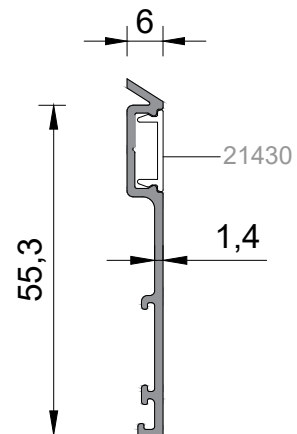
21429

border profile

CODE	WEIGHT(kg/m)	Ix cm ⁴	Iy cm ⁴
21430	0.060	-	-
21413	0.150	-	-
21416	0.130	-	-
21450	0.170	-	-

21430

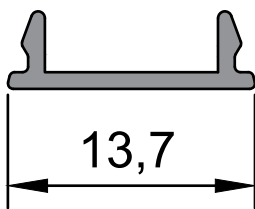

cover profile

21413

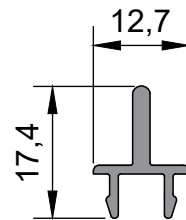

adapter profile

21416

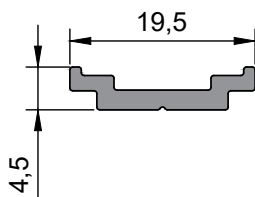

rod profile

21450

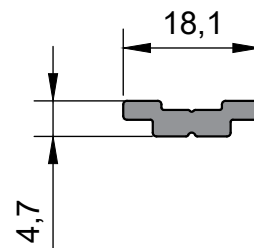

rod profile

CODE	WEIGHT(kg/m)	Ix cm ⁴	Iy cm ⁴
21498	0.265	-	-
21411	0.49	-	-
21503	0.477	-	-
21499A	0.120	-	-

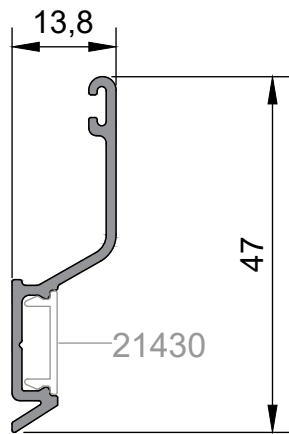
21498

flyscreen sash rail

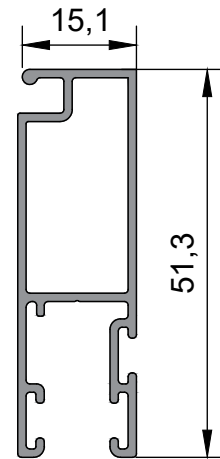
21411

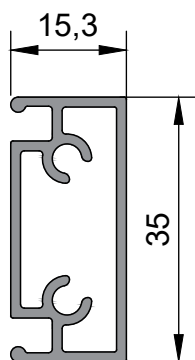

flyscreen sash profile

21503

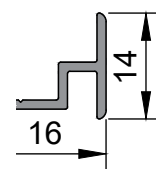
T for flyscreen sash

21499A

biuaty profil

profile	corner cleat	shape	cutting size	button length
21411	C22.4		13 mm 	15 mm

CODE	WEIGHT(kg/m)	Ix cm ⁴	Iy cm ⁴
3823	0.282	-	-
3822	0.268	-	-
3821	0.246	-	-
38102	0.231	-	-

3823

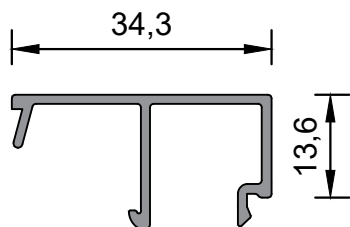

glazing bead

3822

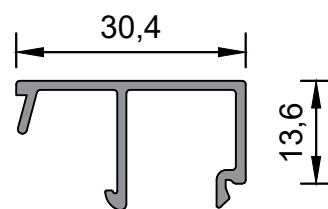

glazing bead

3821

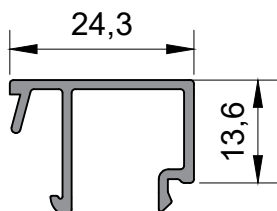

glazing bead

38102

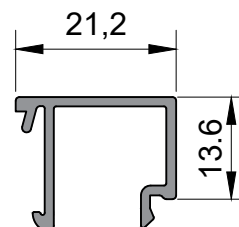

glazing bead

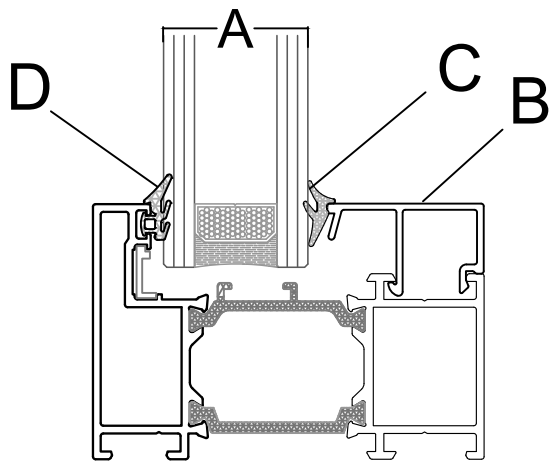

A (mm)	B	C	D
20	1007	3823	mo68
22	1005	3823	mo68
24	1003	3823	mo68
26	1005	3822	mo68
28	1003	3822	mo68
30	1007	3821	mo68
32	1005	3821	mo68
34	1003	3821	mo68
36	1004	38102	mo68
38	1002	38102	mo68

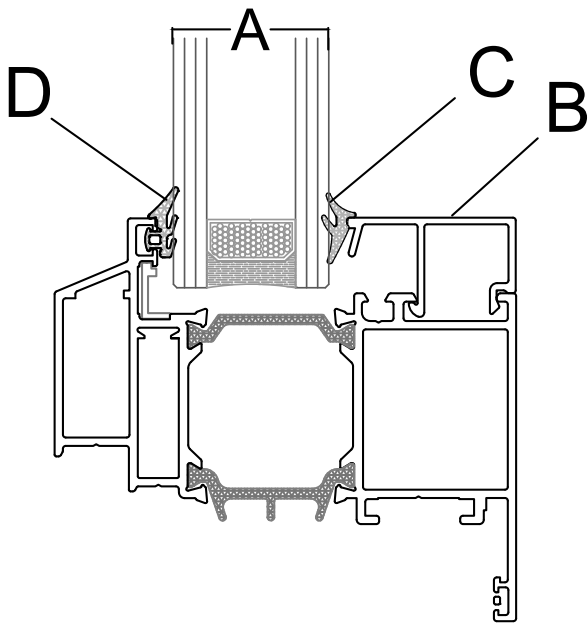

CS59

CS68

CS68F

CS68H

CS77

CS77H

MASTERLINE8

SLIMLINE38

S560

S560 Mono

S560 Threshold

- CS59
- CS68
- CS68F
- CS68H
- CS77
- CS77H
- MASTERLINE8
- SLIMLINE38
- S560
- S560 Mono
- S560 Threshold

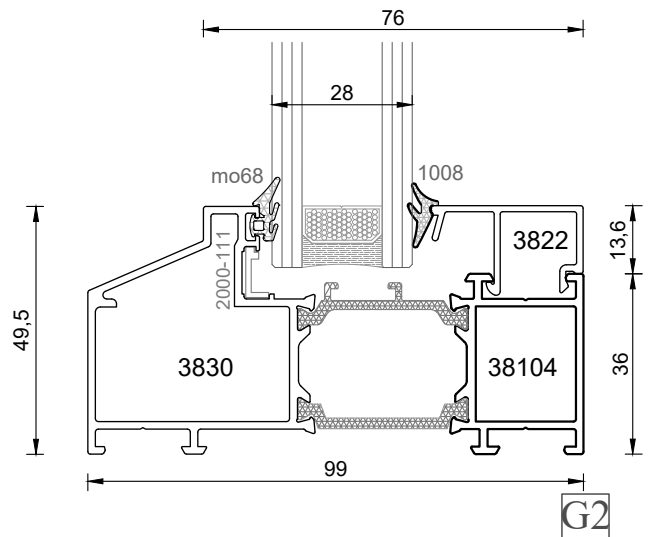
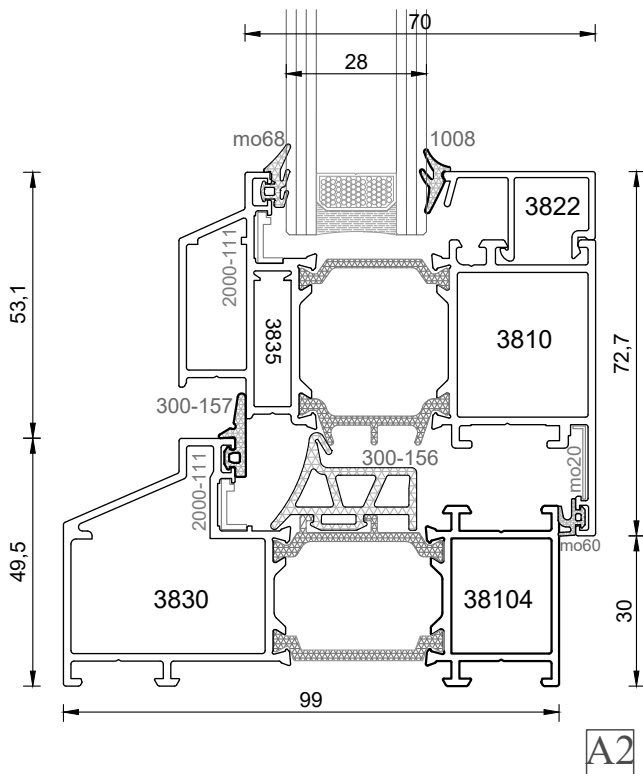
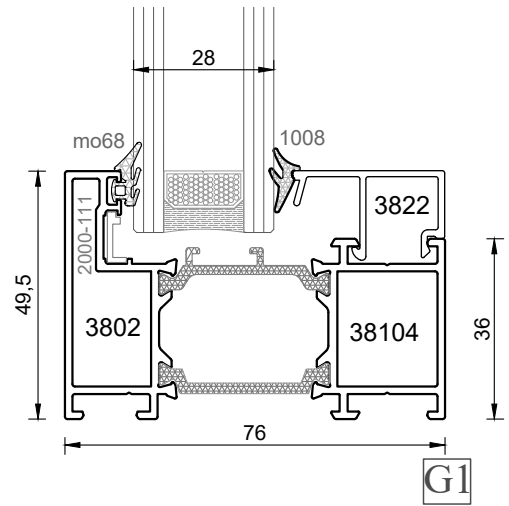
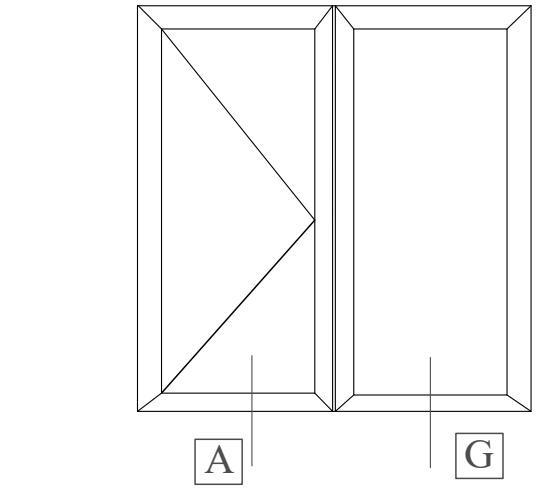
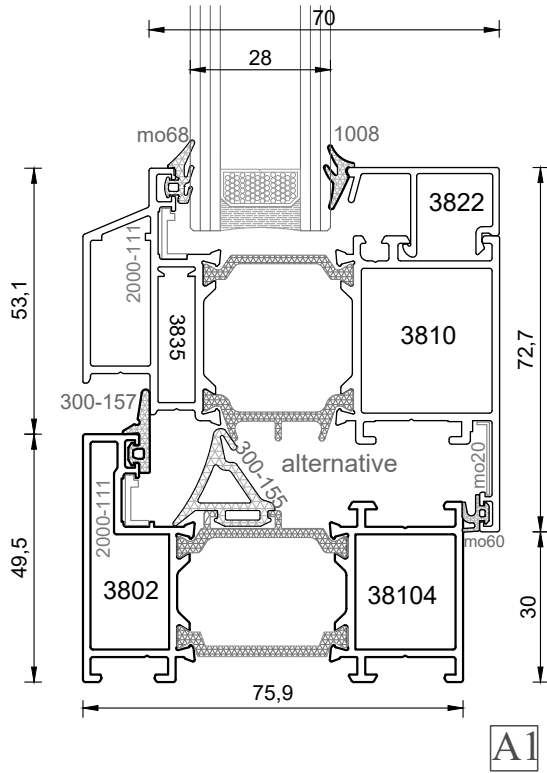

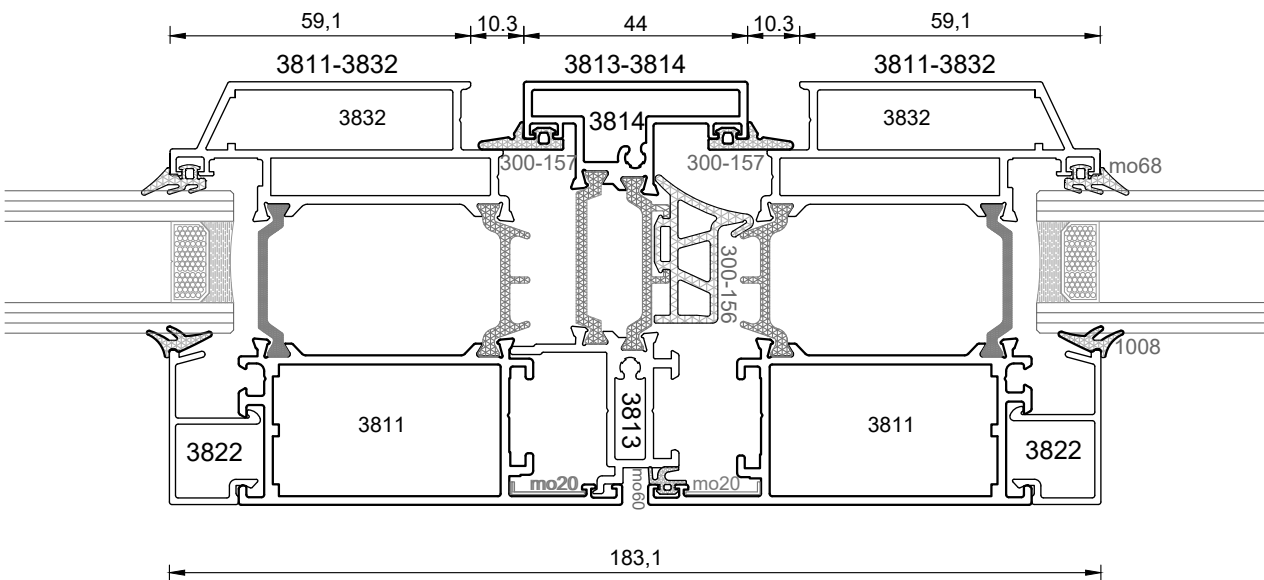
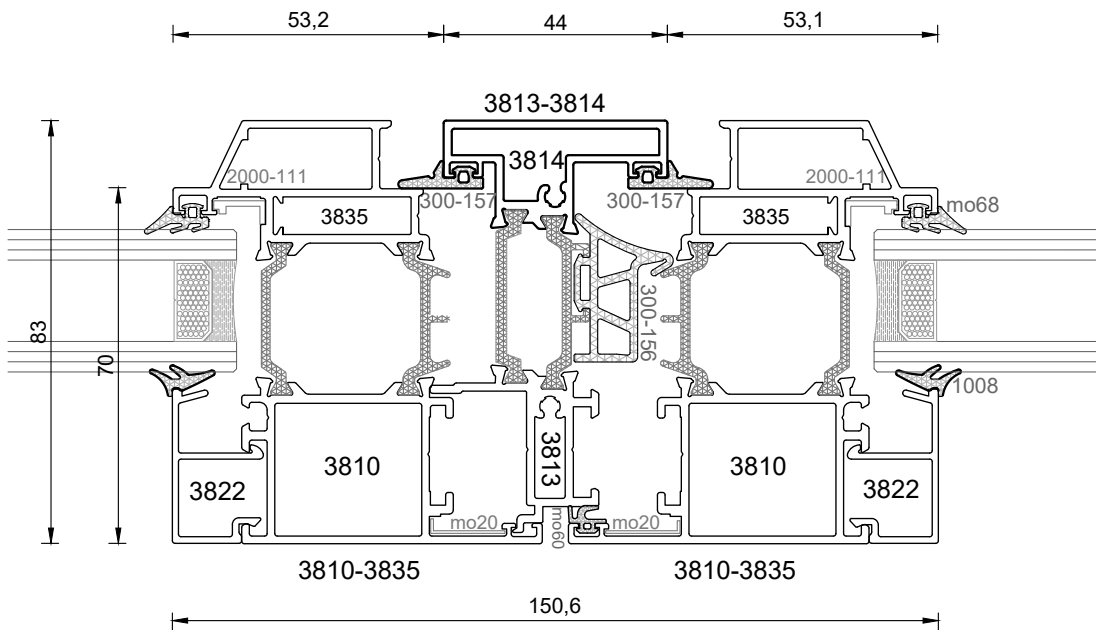
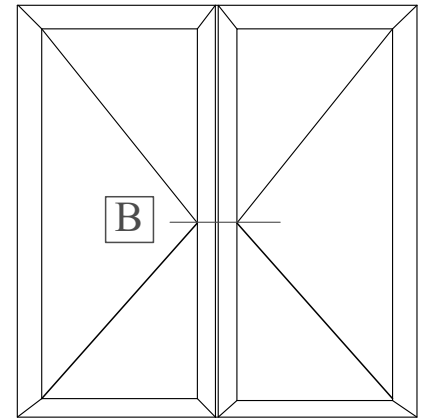

- CS59
- CS68
- CS68F
- CS68H
- CS77
- CS77H
- MASTERLINE8
- SLIMLINE38
- S560
- S560 Mono
- S560 Threshold

- CS59
- CS68
- CS68F
- CS68H
- CS77
- CS77H
- MASTERLINE8
- SLIMLINE38
- S560
- S560 Mono
- S560 Threshold

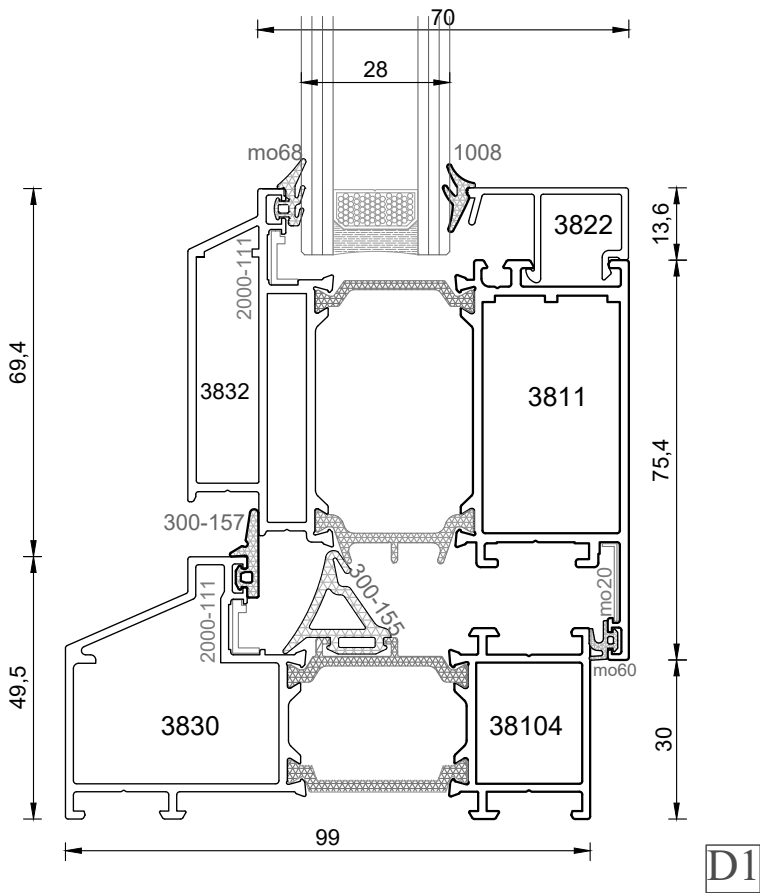
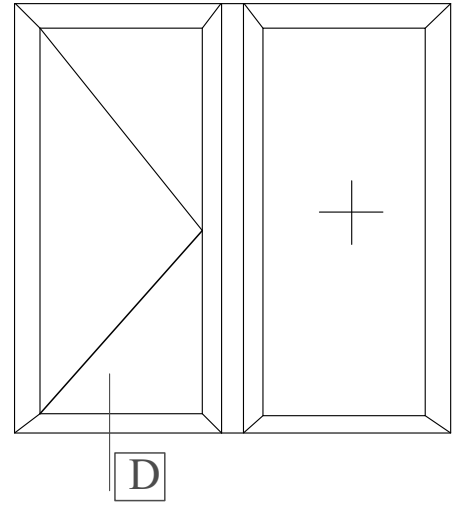
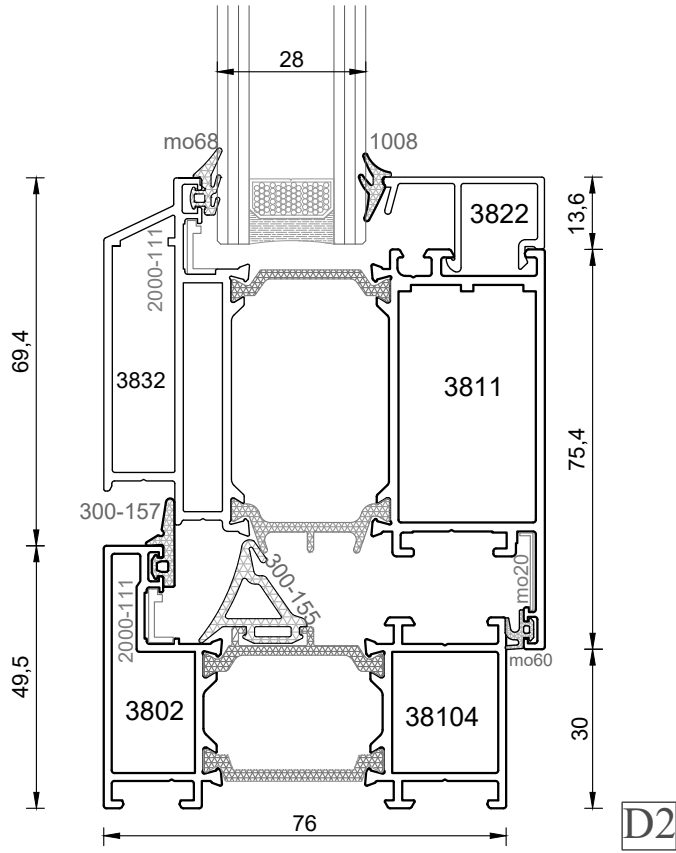

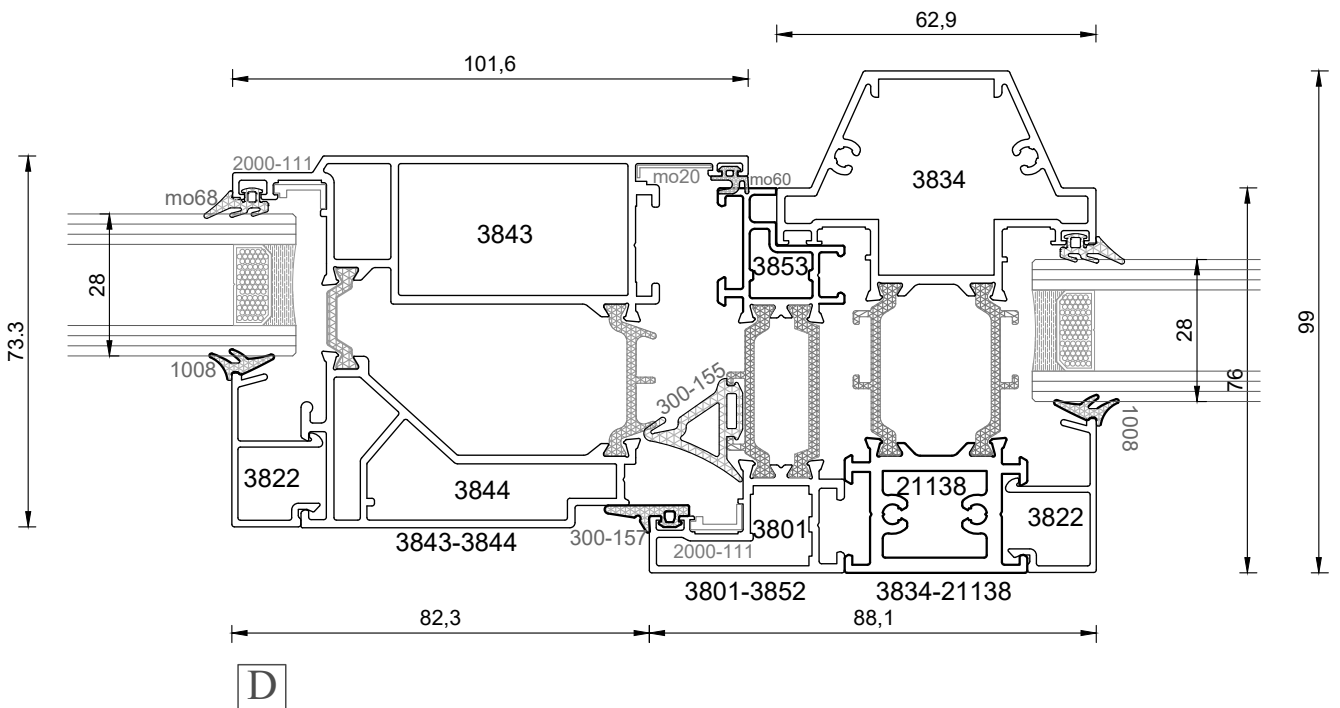
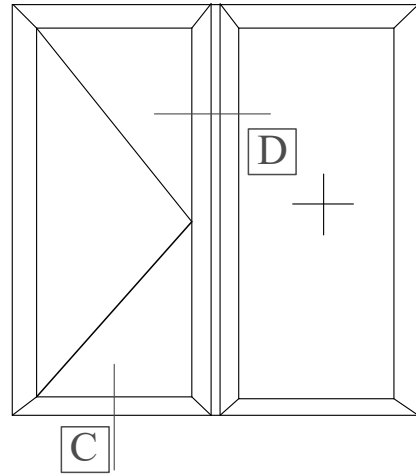
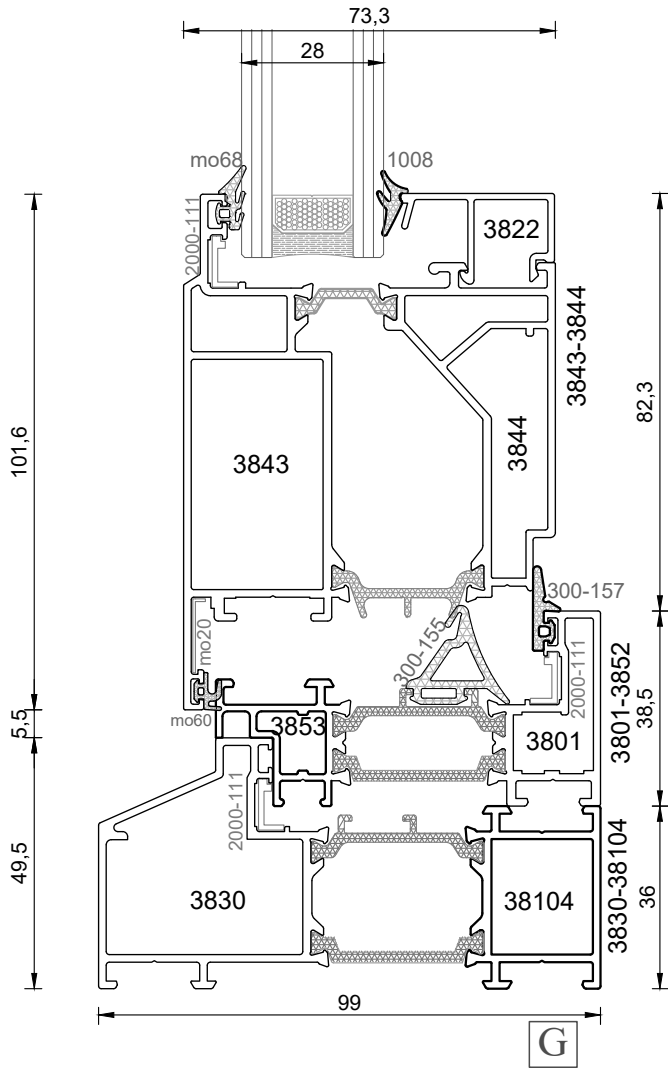

- CS59
- CS68
- CS68F
- CS68H
- CS77
- CS77H
- MASTERLINE8
- SLIMLINE38
- S560
- S560 Mono
- S560 Threshold

- CS59
- CS68
- CS68F
- CS68H
- CS77
- CS77H
- MASTERLINE8
- SLIMLINE38
- S560
- S560 Mono
- S560 Threshold

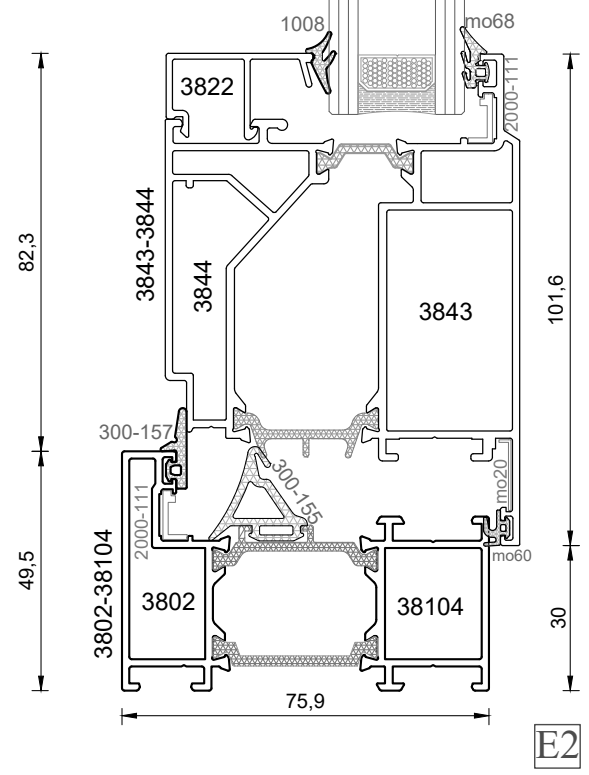
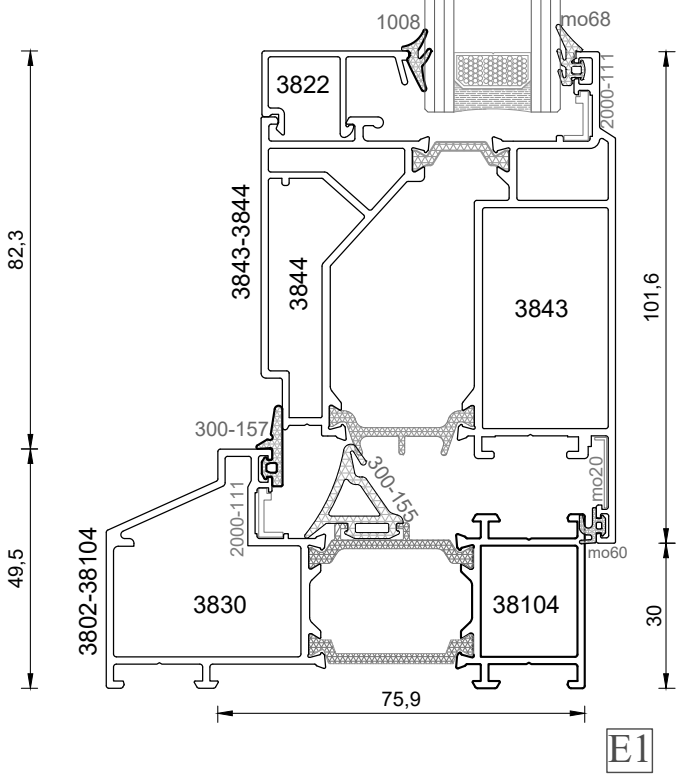
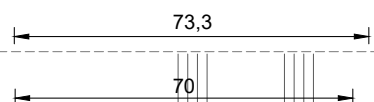
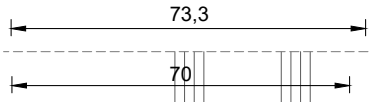
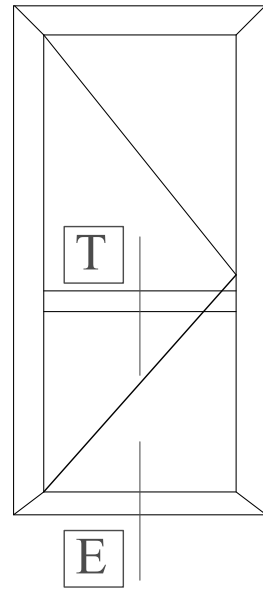
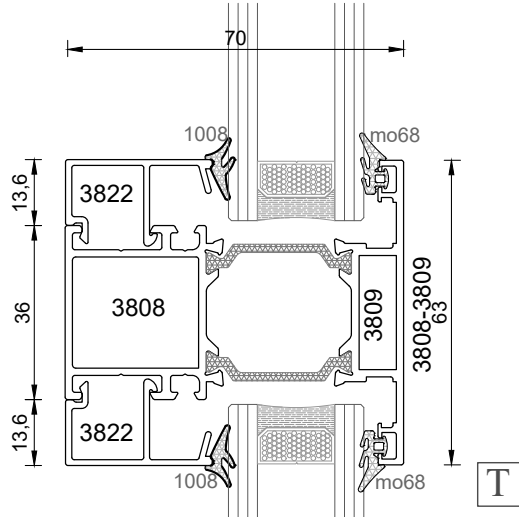

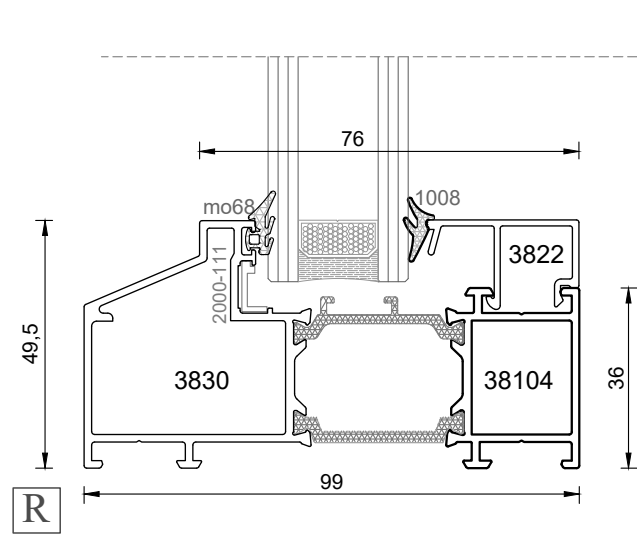
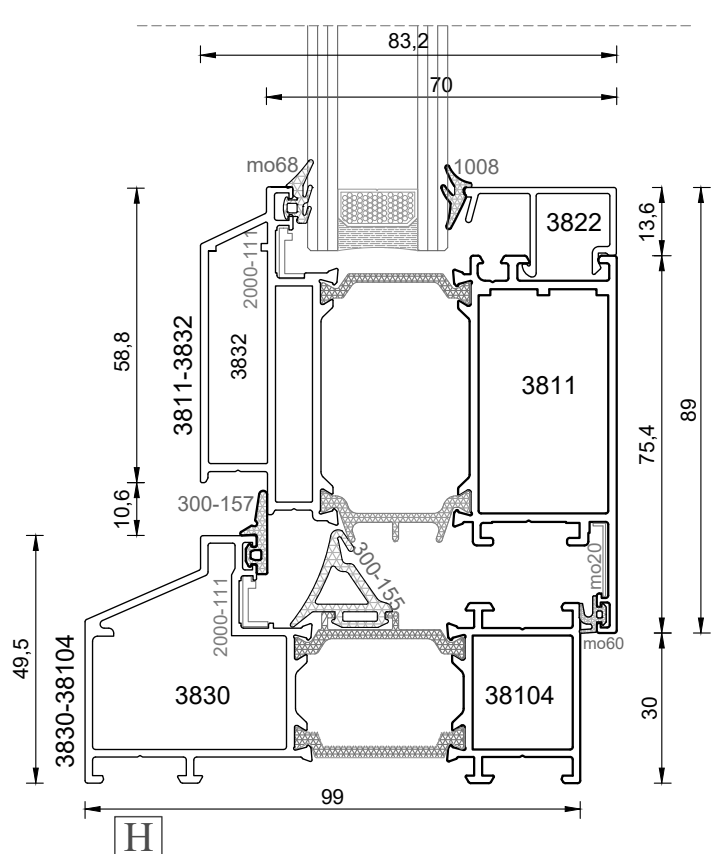
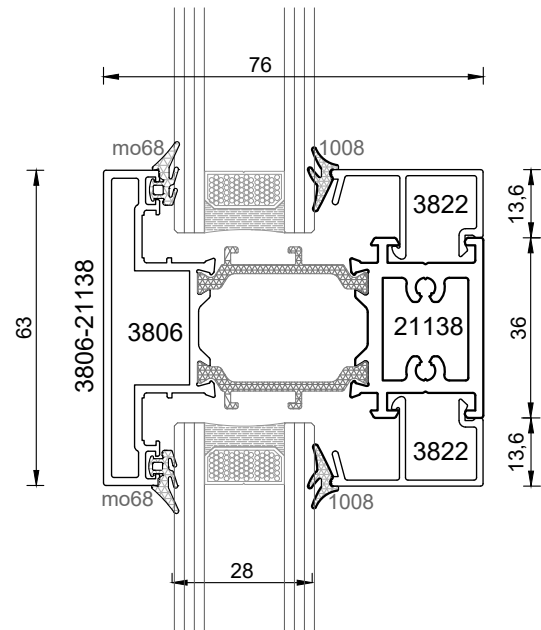
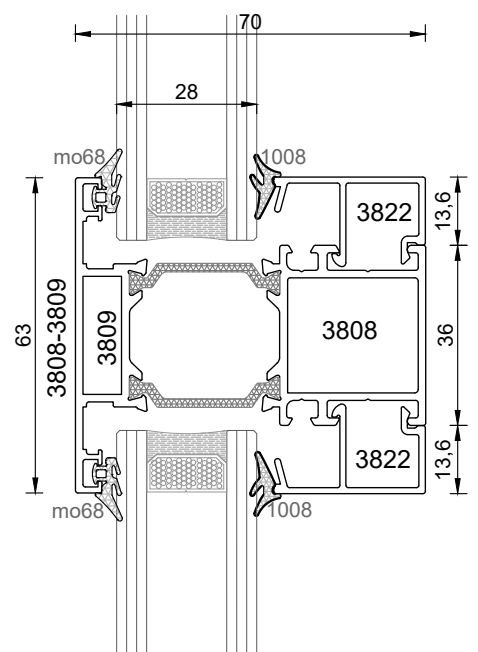
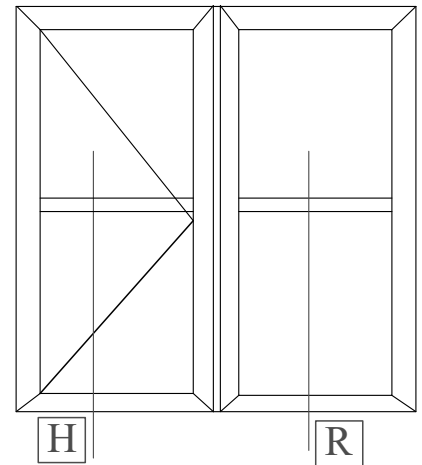

- CS59
- CS68
- CS68F
- CS68H
- CS77
- CS77H
- MASTERLINE8
- SLIMLINE38
- S560
- S560 Mono
- S560 Threshold

SECTIONS

SLIMLINE38

Casement System



CS59

CS68

CS68F

CS68H

CS77

CS77H

MASTERLINE8

SLIMLINE38

S560

S560 Mono

S560 Threshold

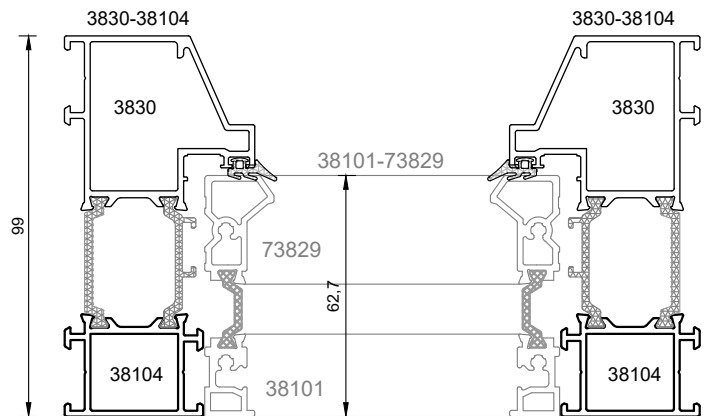
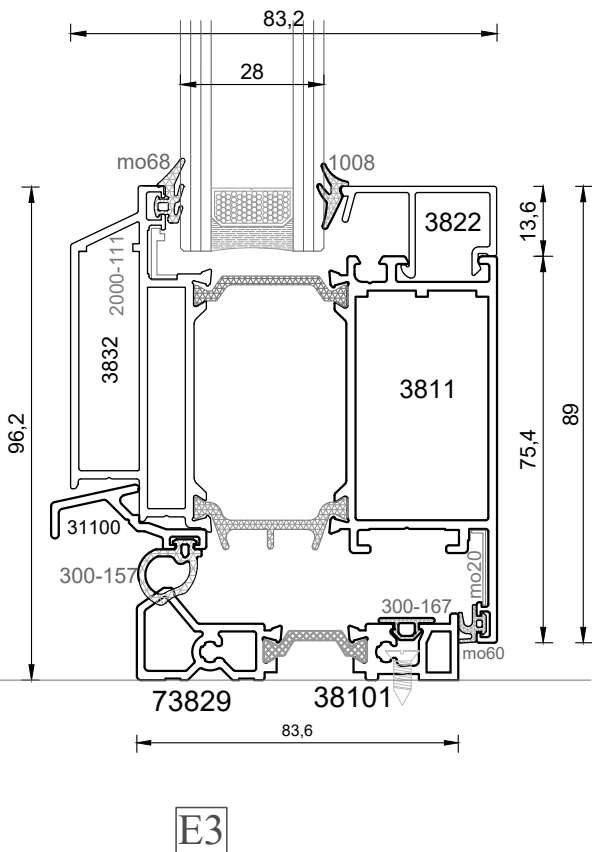
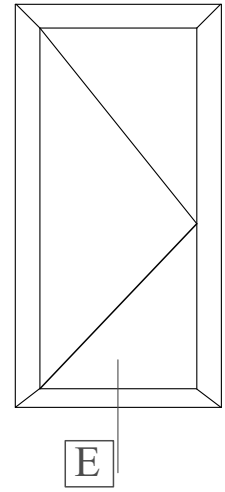
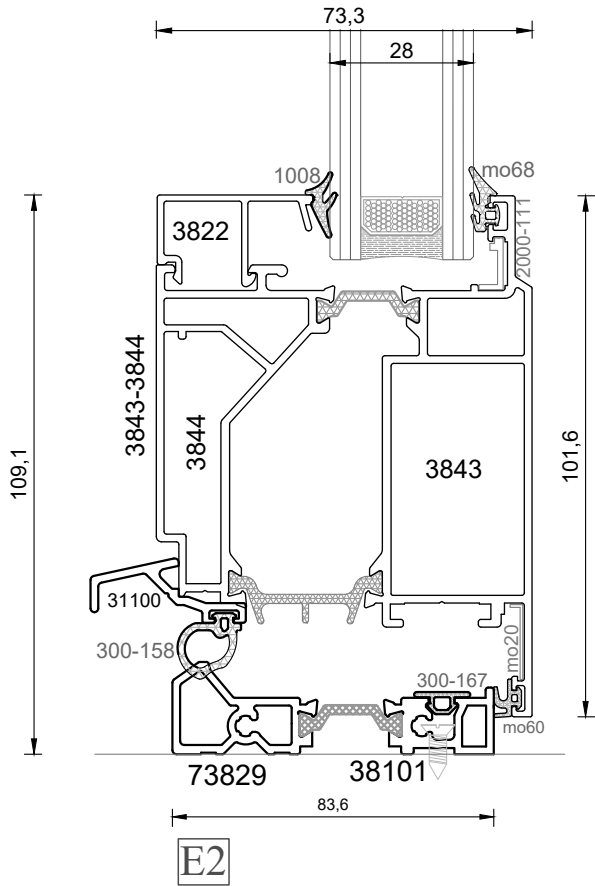

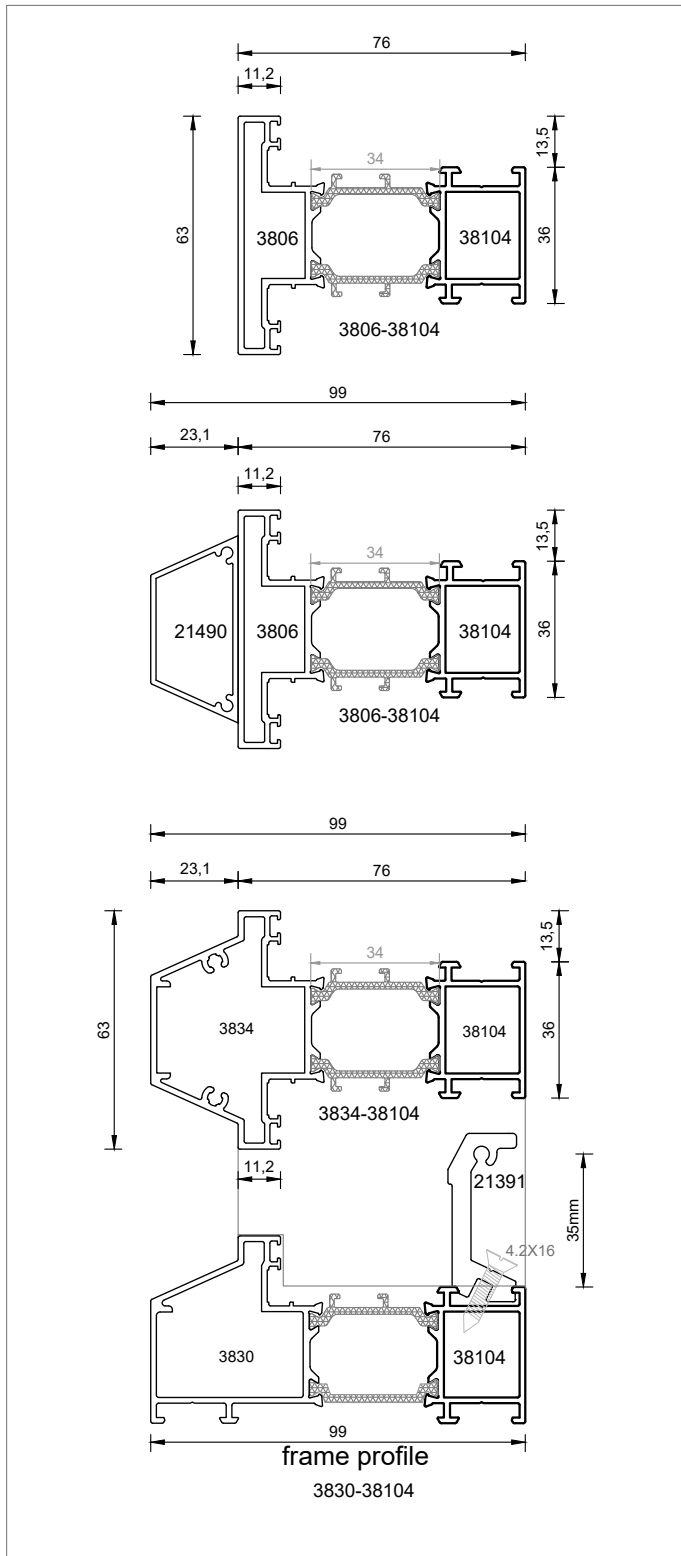

- CS59
- CS68
- CS68F
- CS68H
- CS77
- CS77H
- MASTERLINE8
- SLIMLINE38
- S560
- S560 Mono
- S560 Threshold

SECTIONS

SLIMLINE38

Casement System



- CS59
- CS68
- CS68F
- CS68H
- CS77
- CS77H
- MASTERLINE8
- SLIMLINE38
- S560
- S560 Mono
- S560 Threshold

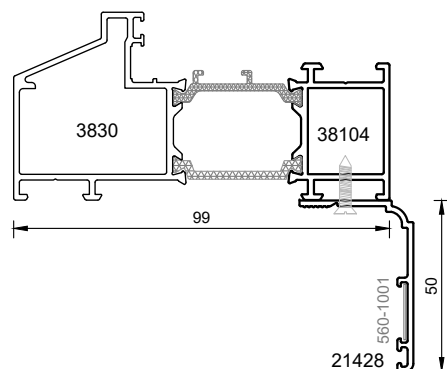
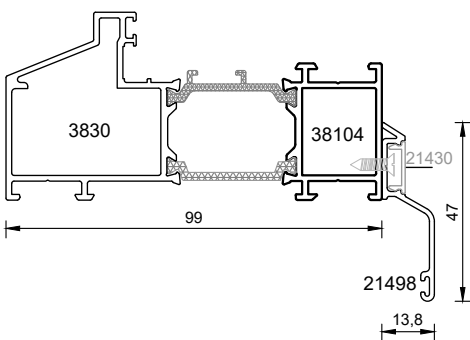
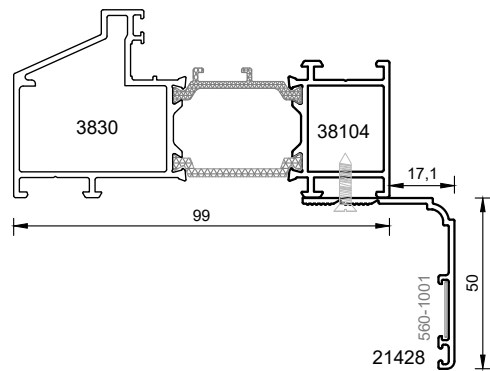
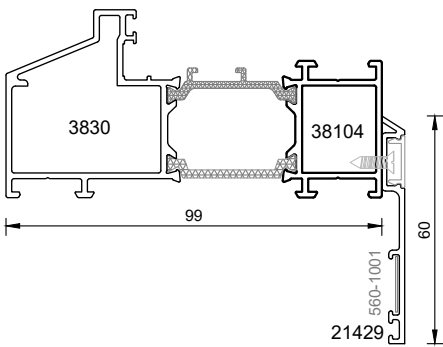
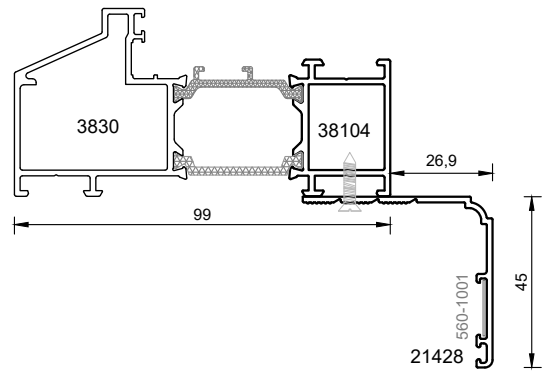
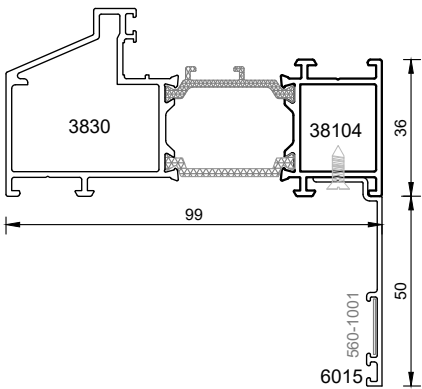
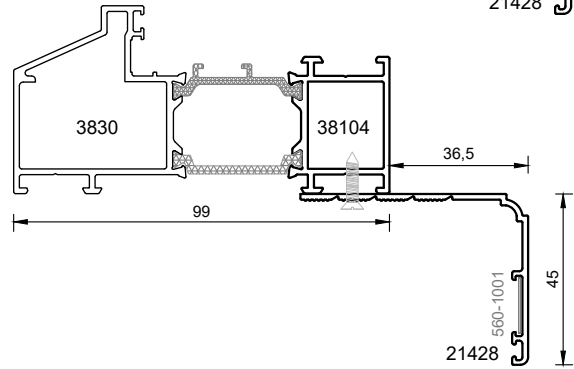
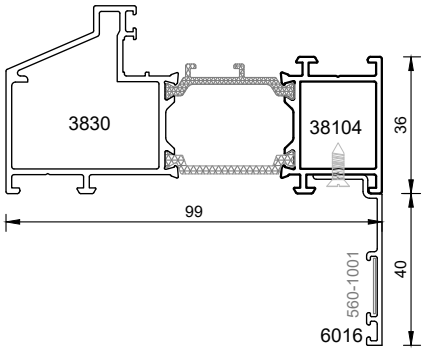
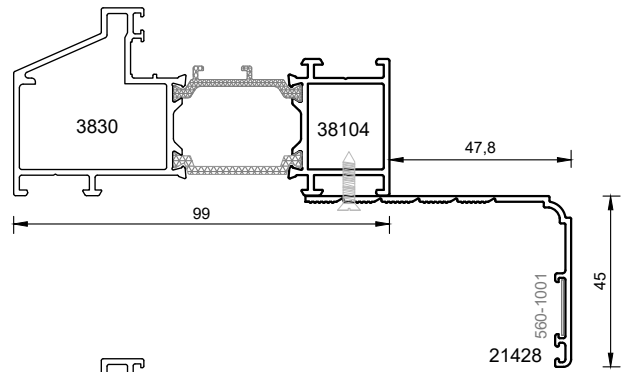
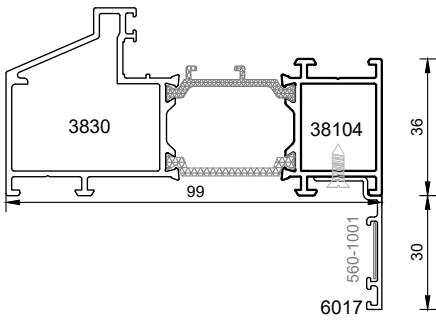

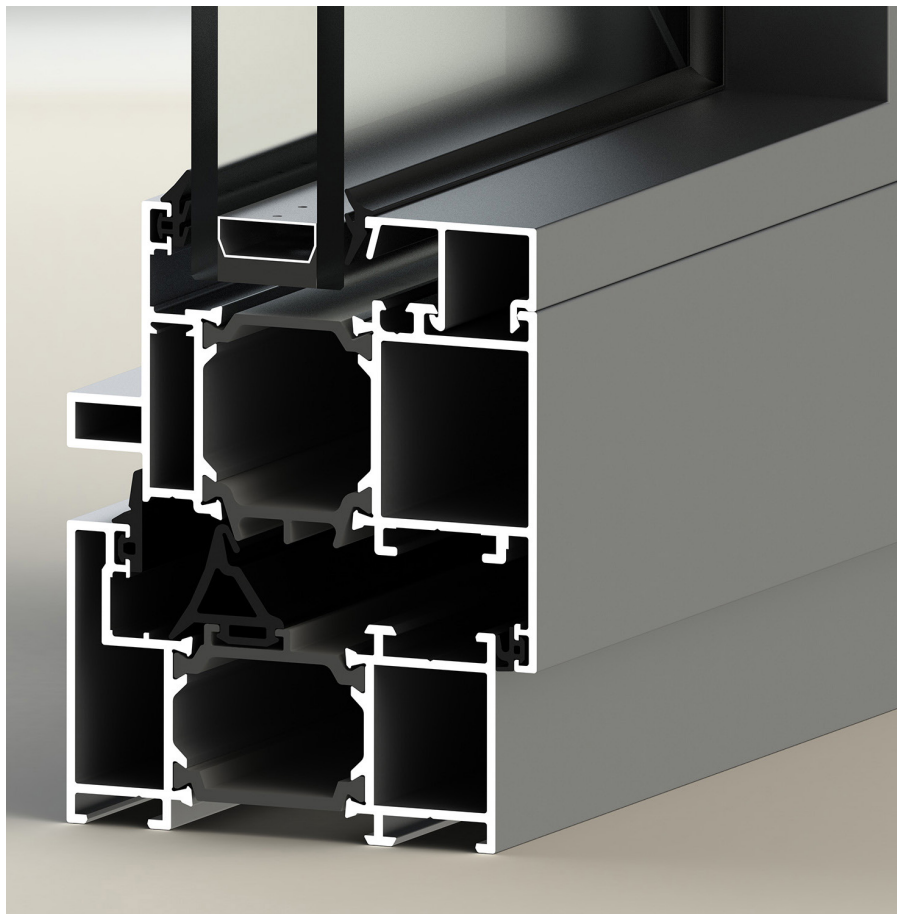

CS59
CS68
CS68F
CS68H
CS77
CS77H
MASTERLINE8
SLIMLINE38
S560
S560 Mono
S560 Threshold

SECTIONS

SLIMLINE38

Casement System



CS59

CS68

CS68F

CS68H

CS77

CS77H

MASTERLINE8

SLIMLINE38

S560

S560 Mono

S560 Threshold

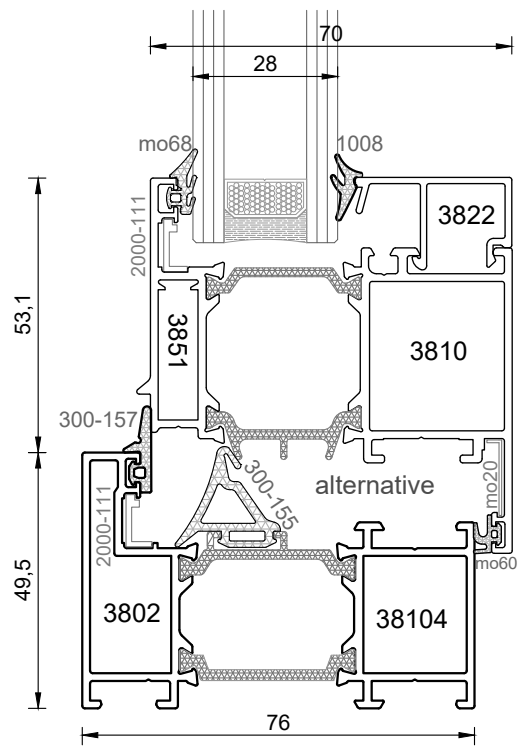
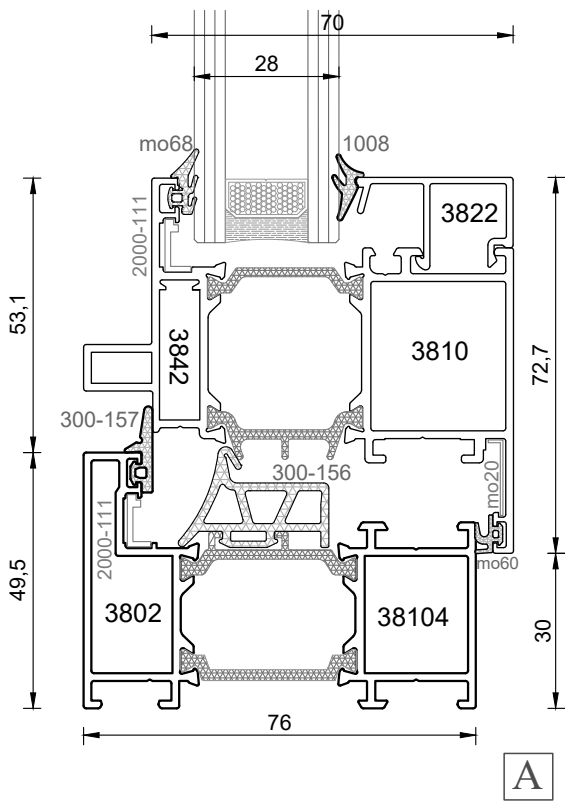
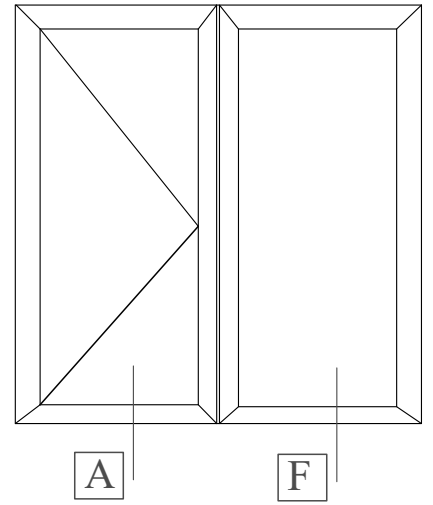
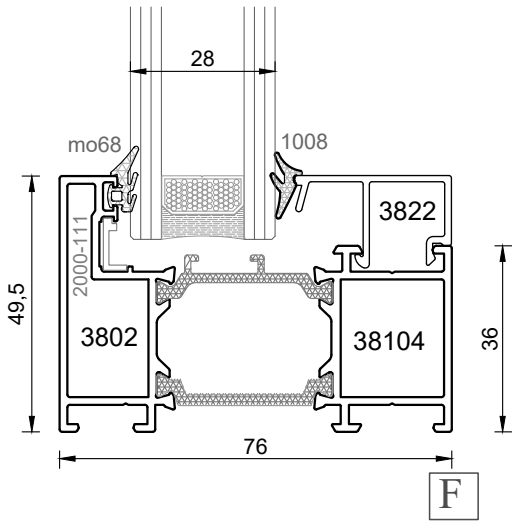

- CS59
- CS68
- CS68F
- CS68H
- CS77
- CS77H
- MASTERLINE8
- SLIMLINE38
- S560
- S560 Mono
- S560 Threshold

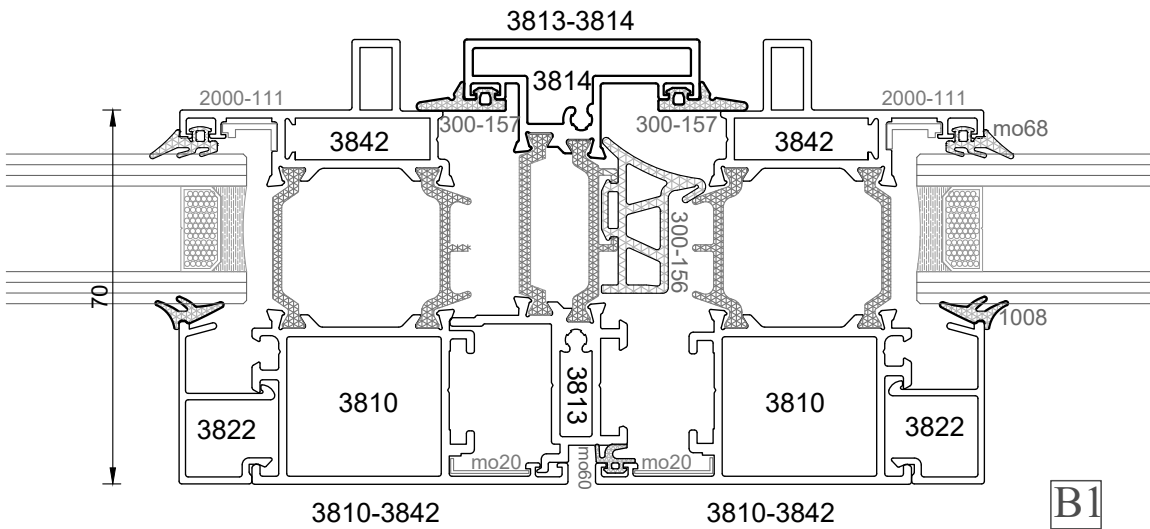
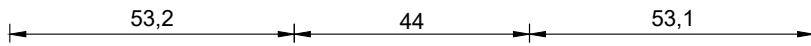
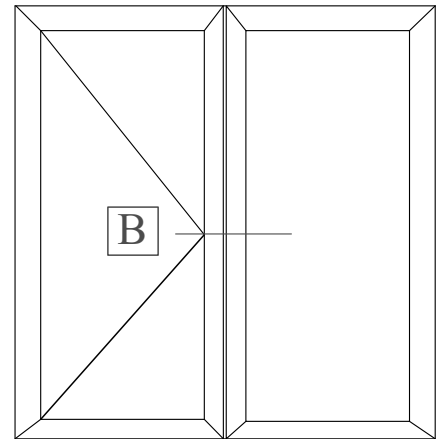

B1

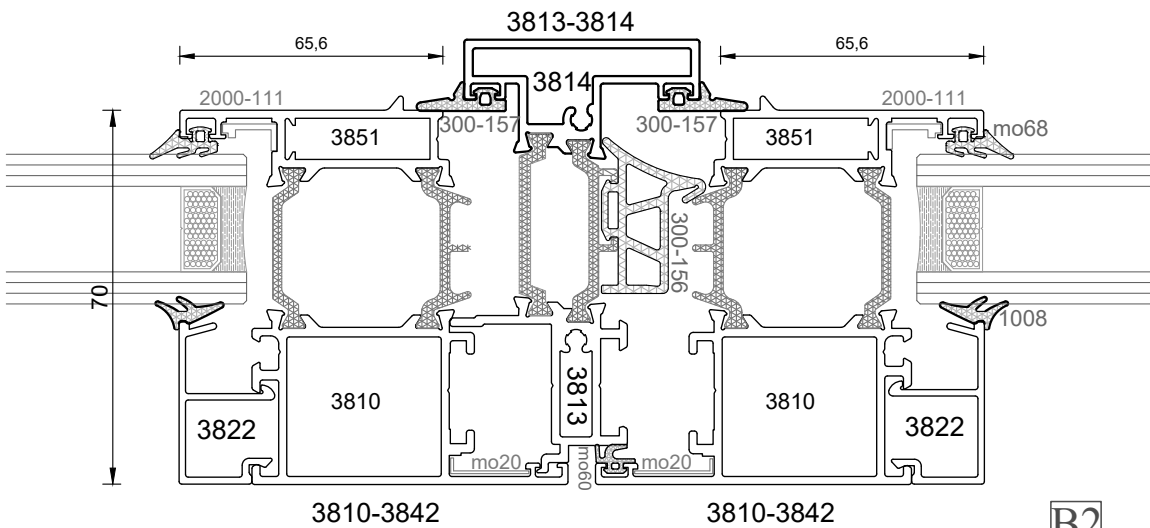
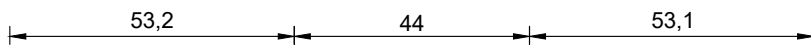

B2

SECTIONS

SLIMLINE38

Casement System



- CS59
- CS68
- CS68F
- CS68H
- CS77
- CS77H
- MASTERLINE8
- SLIMLINE38
- S560
- S560 Mono
- S560 Threshold

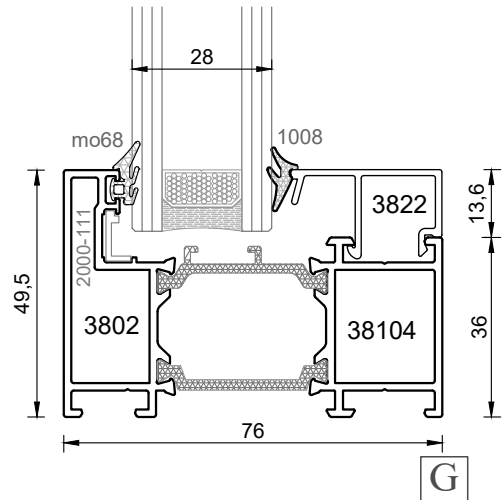
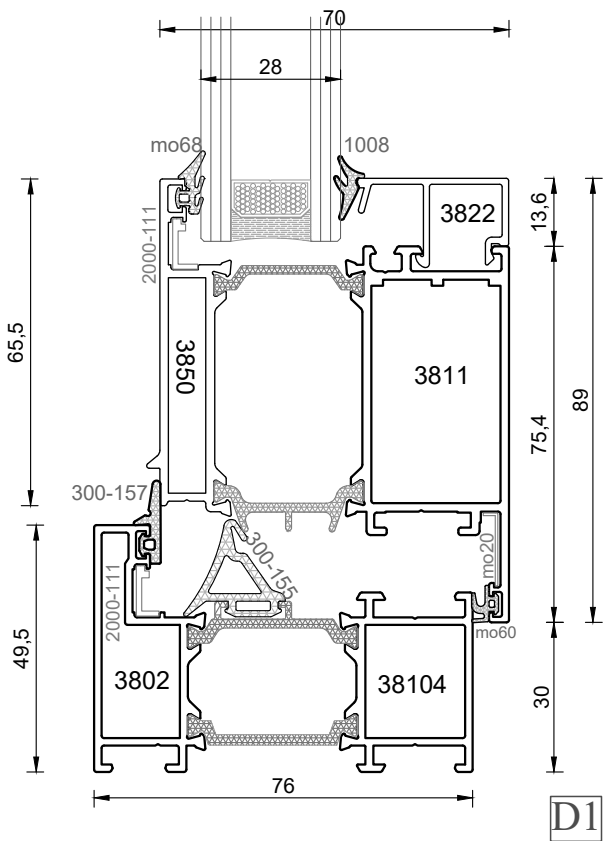
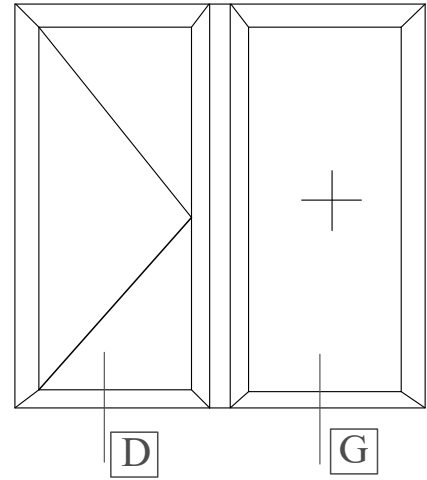
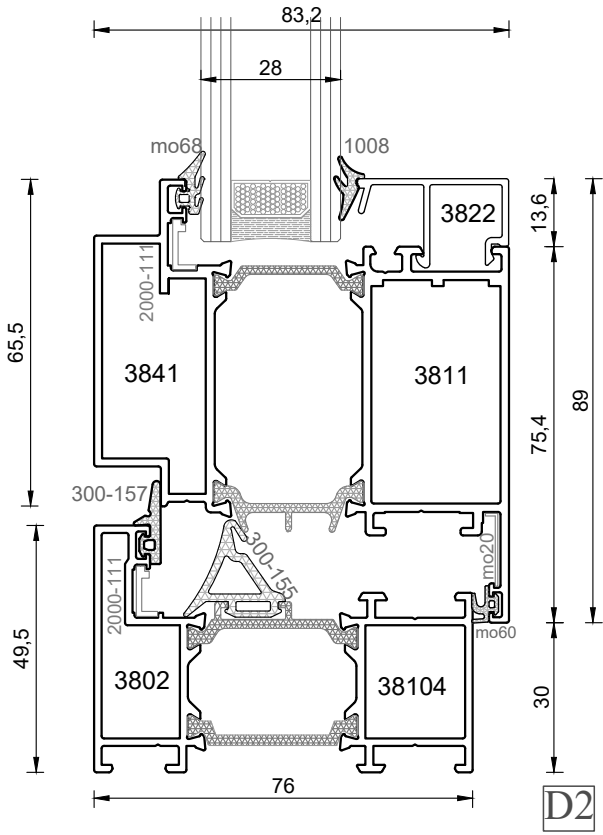

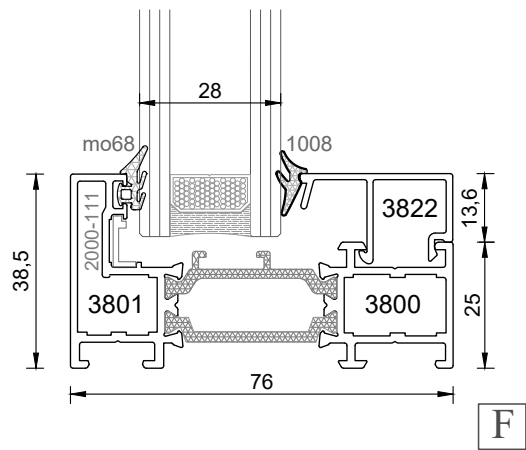
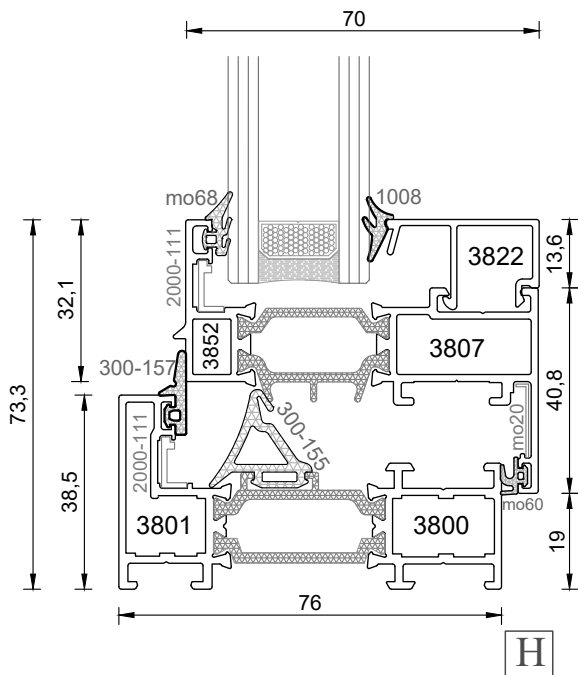
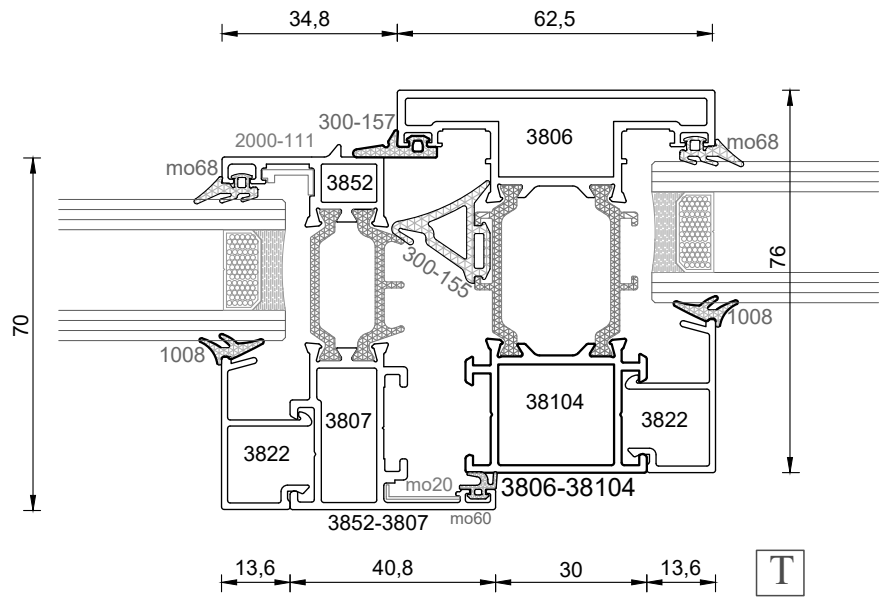
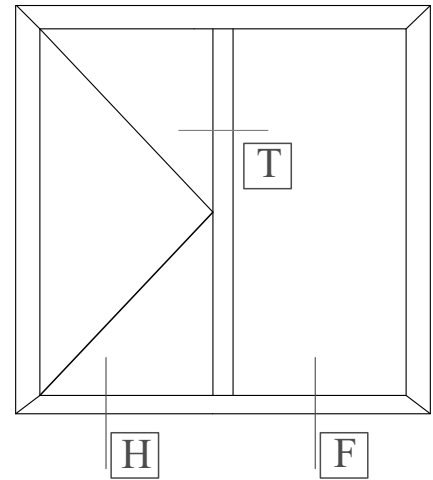

CS59
CS68
CS68F
CS68H
CS77
CS77H
MASTERLINE8
SLIMLINE38
S560
S560 Mono
S560 Threshold

SECTIONS

SLIMLINE38

Casement System



- CS59
- CS68
- CS68F
- CS68H
- CS77
- CS77H
- MASTERLINE8
- SLIMLINE38
- S560
- S560 Mono
- S560 Threshold

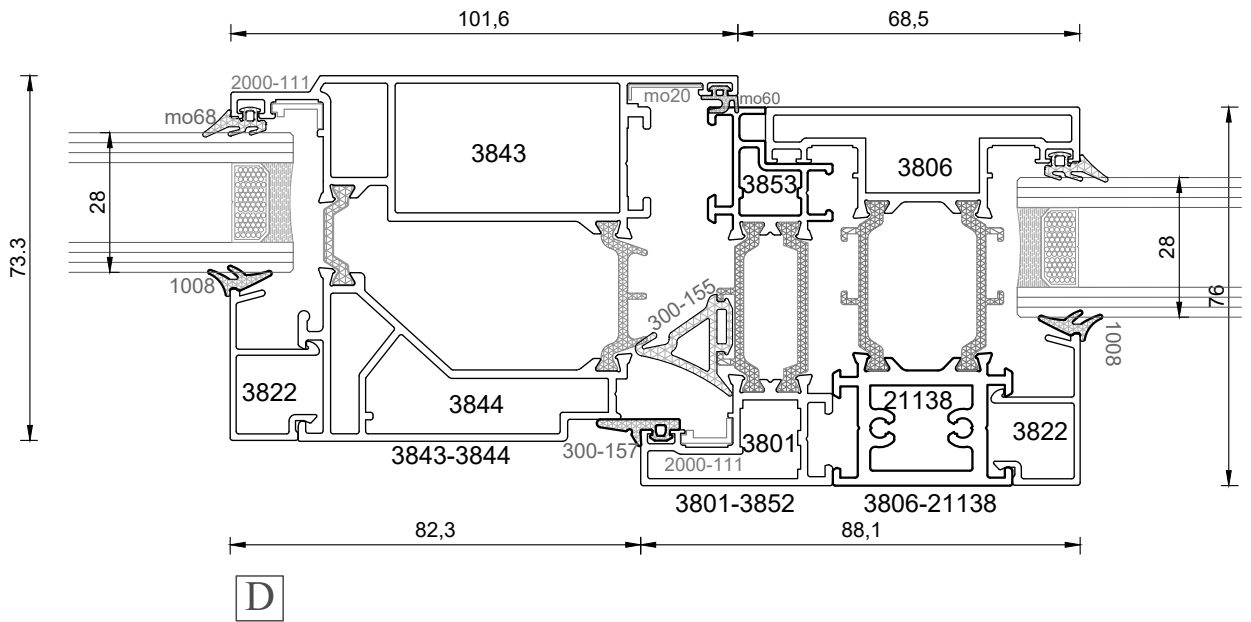
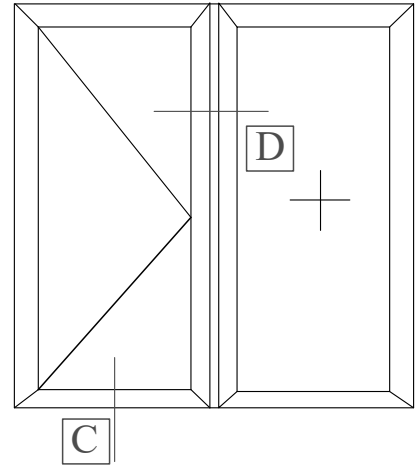
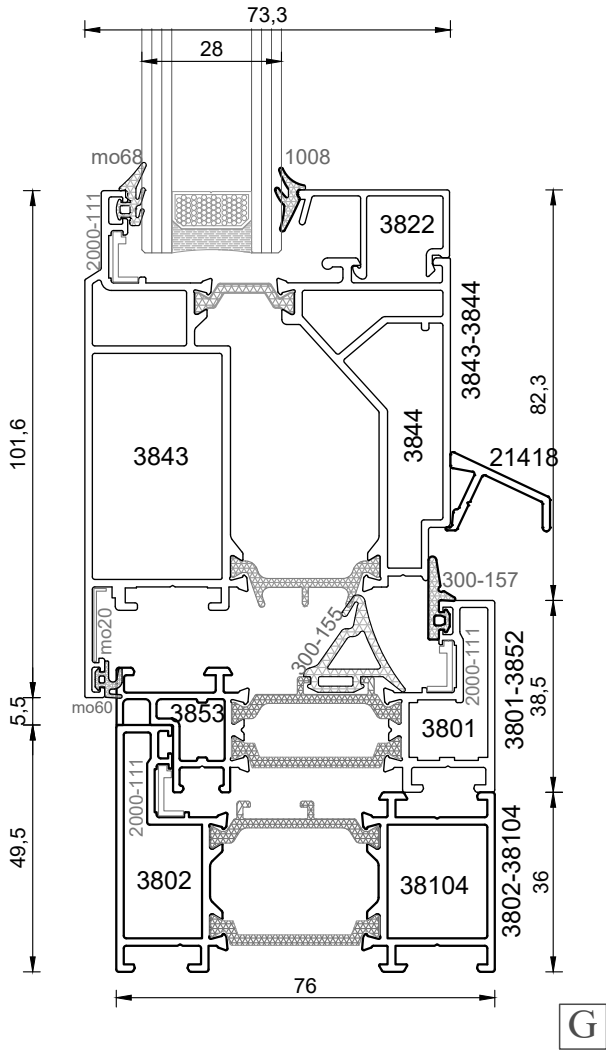

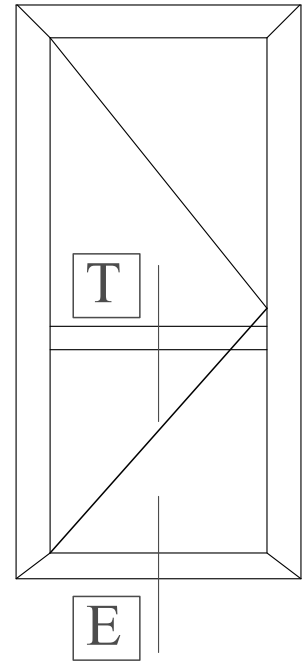
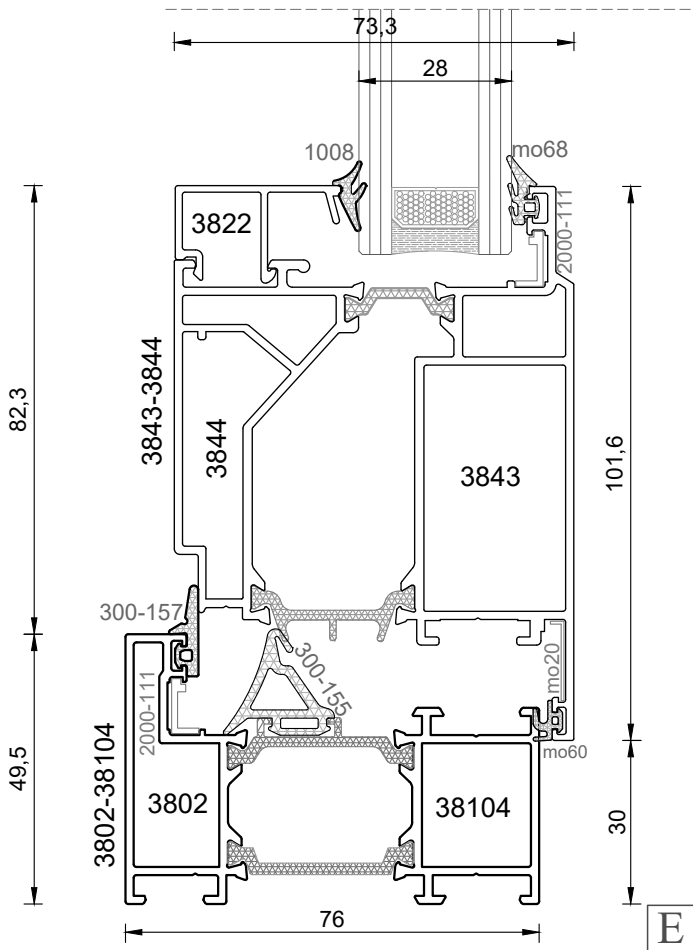
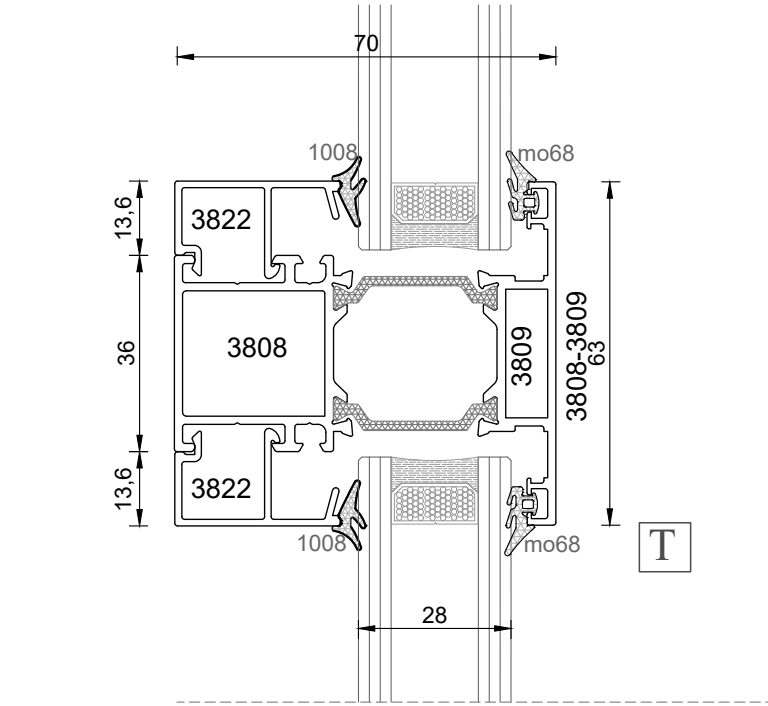

CS59
CS68
CS68F
CS68H
CS77
CS77H
MASTERLINE8
SLIMLINE38
S560
S560 Mono
S560 Threshold

- CS59
- CS68
- CS68F
- CS68H
- CS77
- CS77H
- MASTERLINE8
- SLIMLINE38
- S560
- S560 Mono
- S560 Threshold

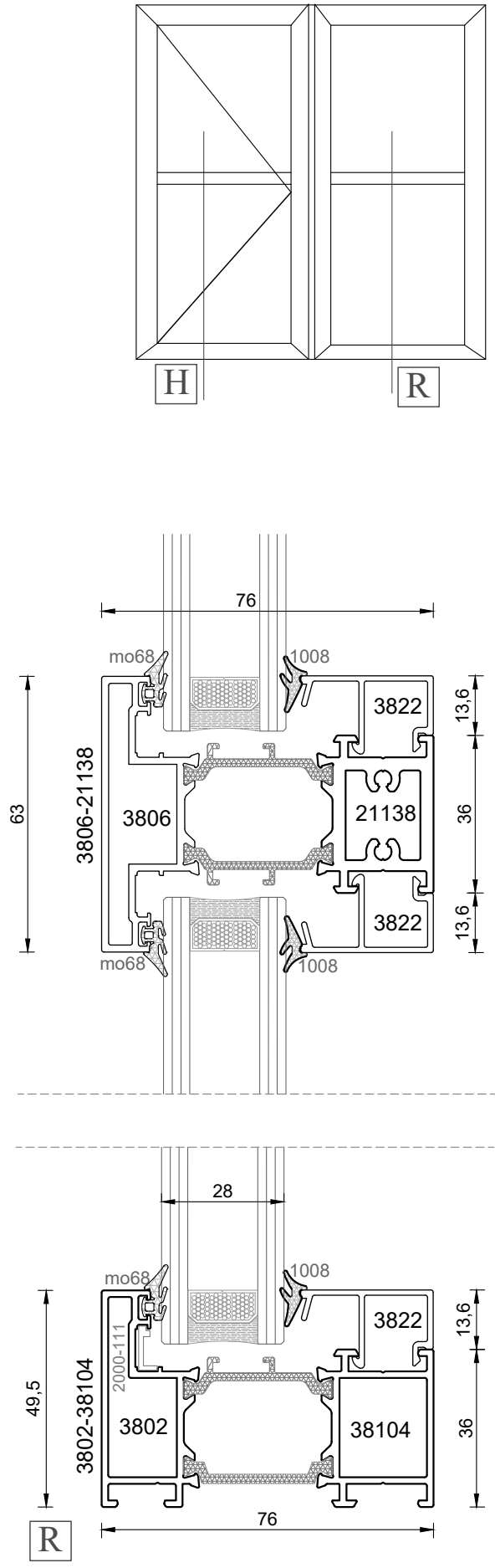
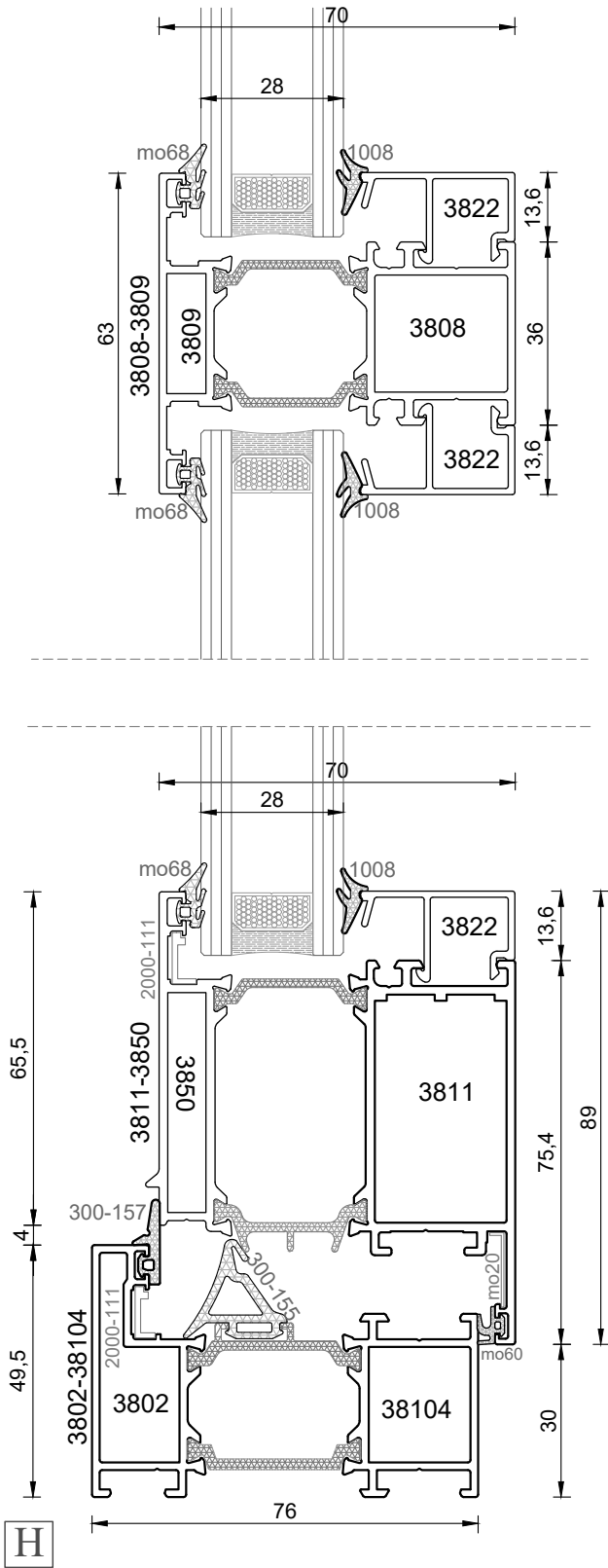

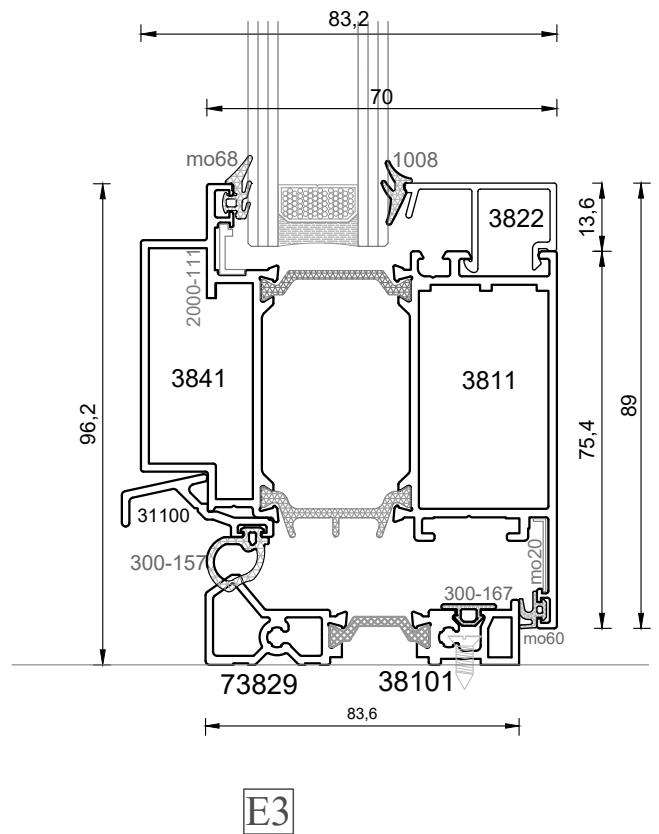
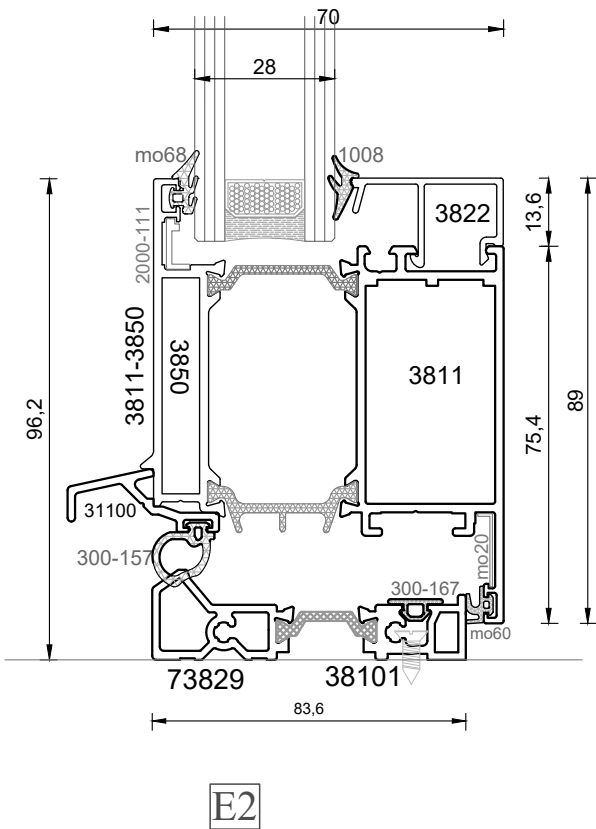
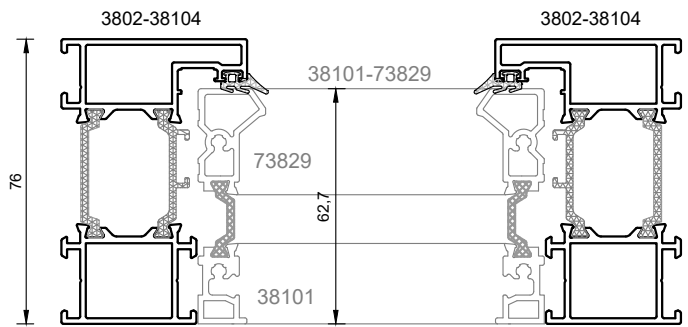
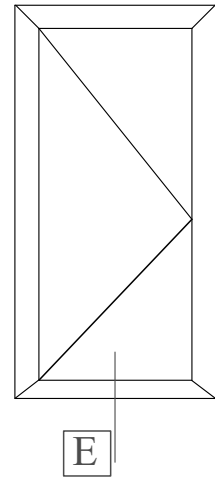
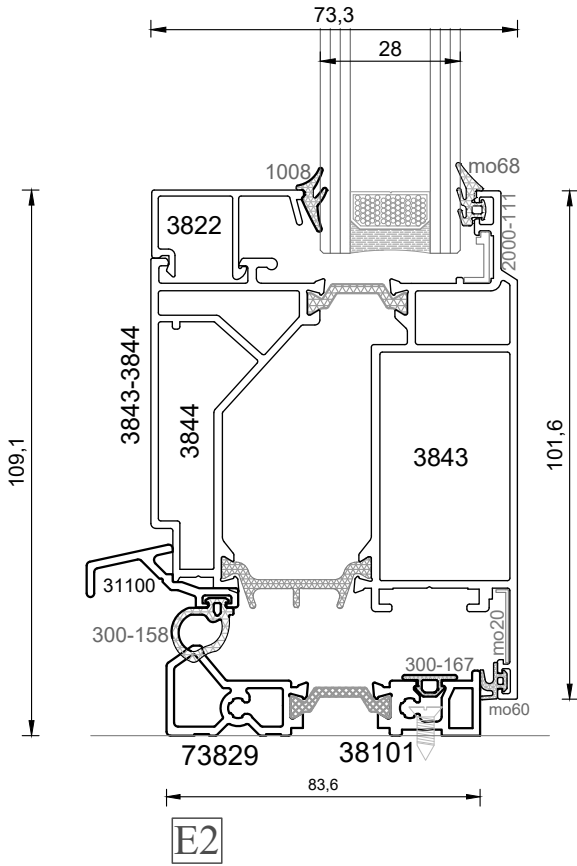

- CS59
- CS68
- CS68F
- CS68H
- CS77
- CS77H
- MASTERLINE8
- SLIMLINE38
- S560
- S560 Mono
- S560 Threshold

SECTIONS

SLIMLINE38

Casement System



CS59

CS68

CS68F

CS68H

CS77

CS77H

MASTERLINE8

SLIMLINE38

S560

S560 Mono

S560 Threshold

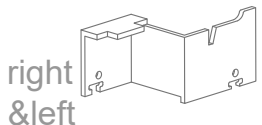
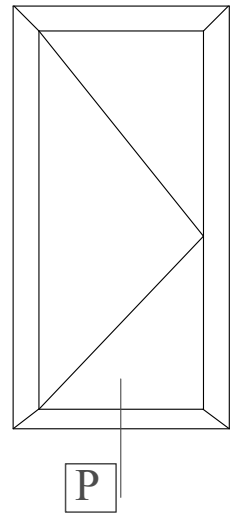
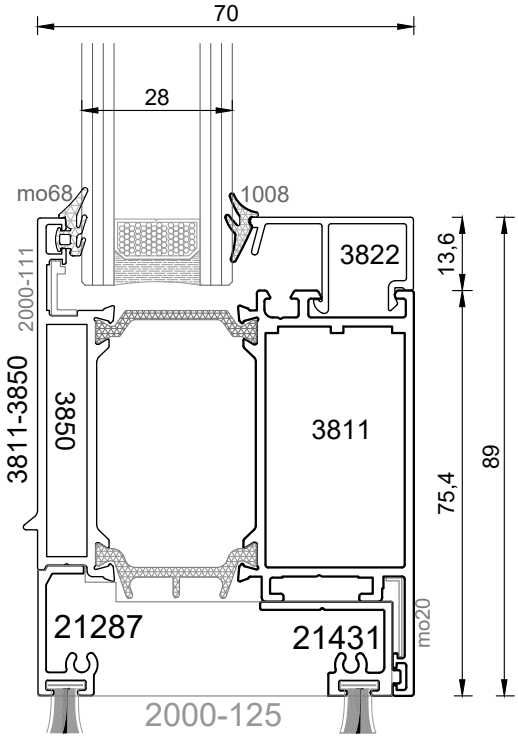

code :2000-187

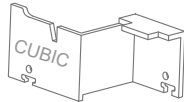

bottom plate caps

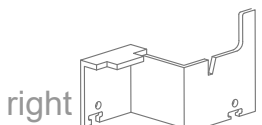
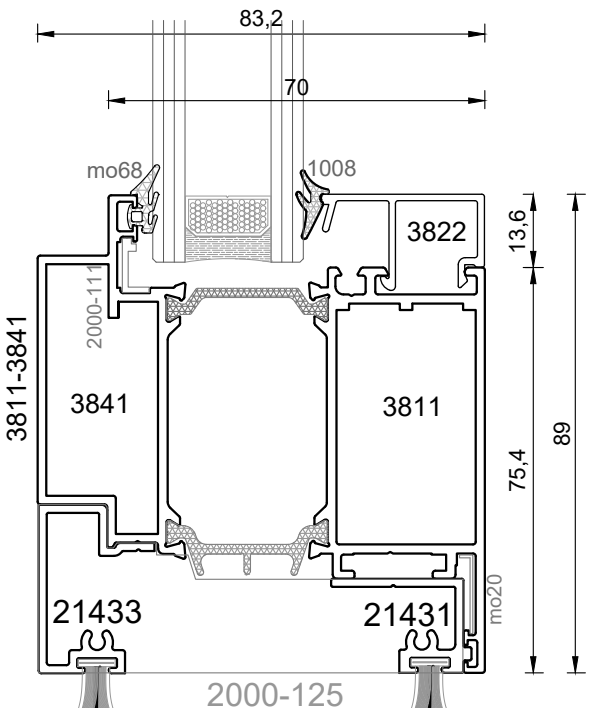

code :2000-186



bottom plate caps

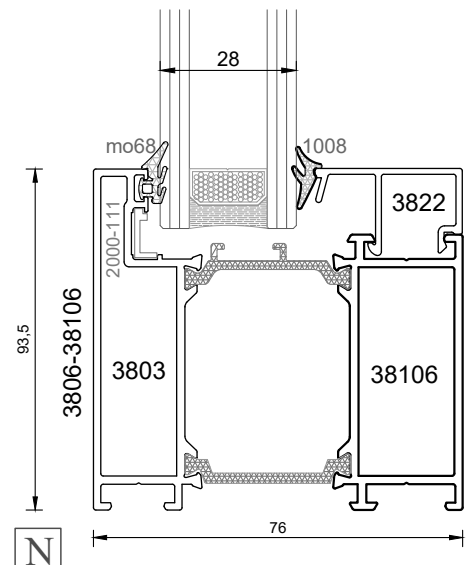
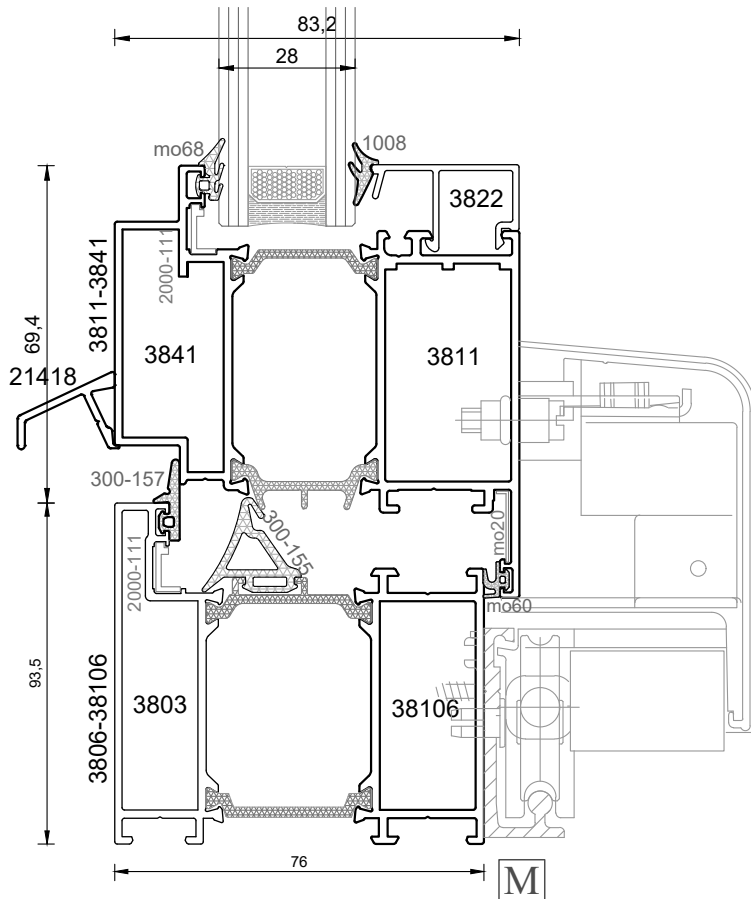
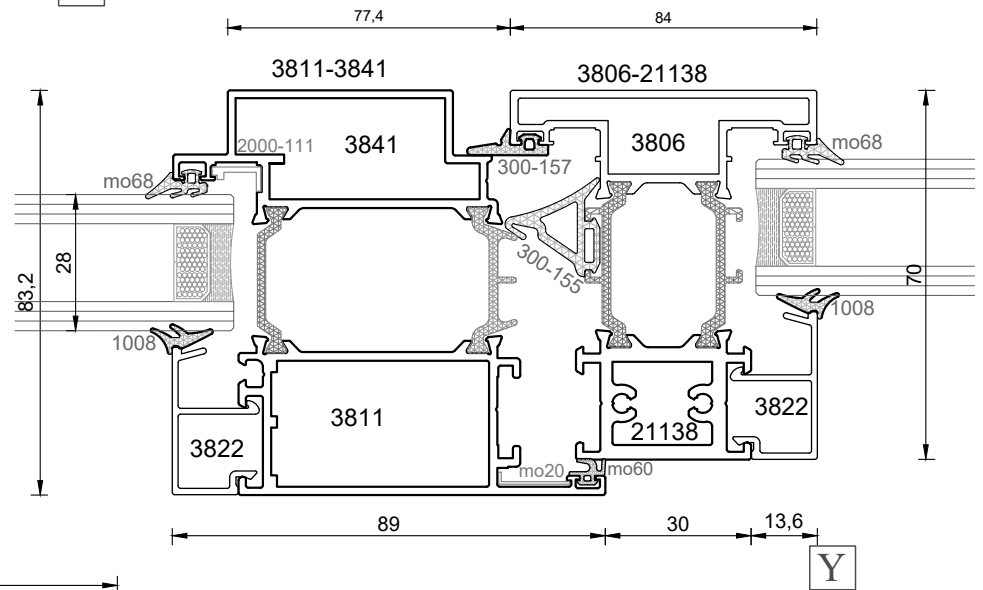
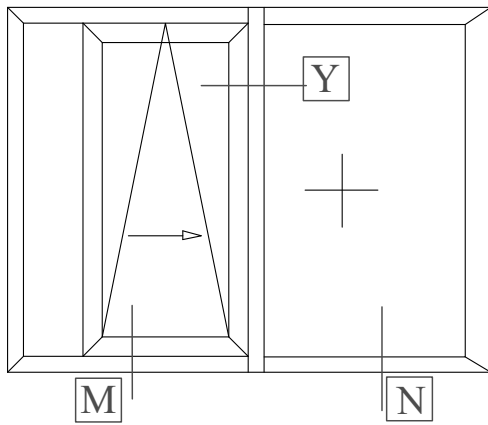

- CS59
- CS68
- CS68F
- CS68H
- CS77
- CS77H
- MASTERLINE8
- SLIMLINE38
- S560
- S560 Mono
- S560 Threshold

- CS59
- CS68
- CS68F
- CS68H
- CS77
- CS77H
- MASTERLINE8
- SLIMLINE38
- S560
- S560 Mono
- S560 Threshold

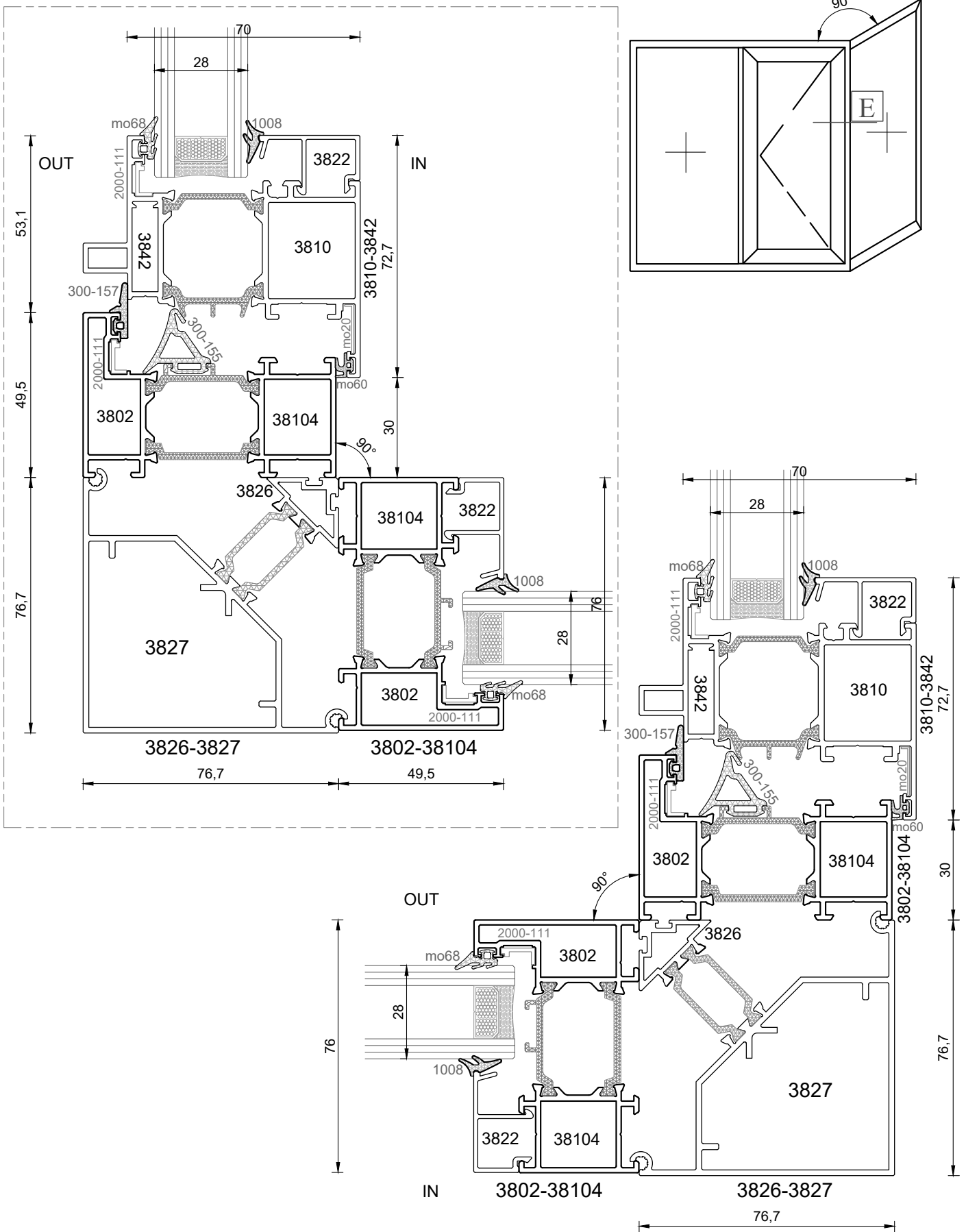

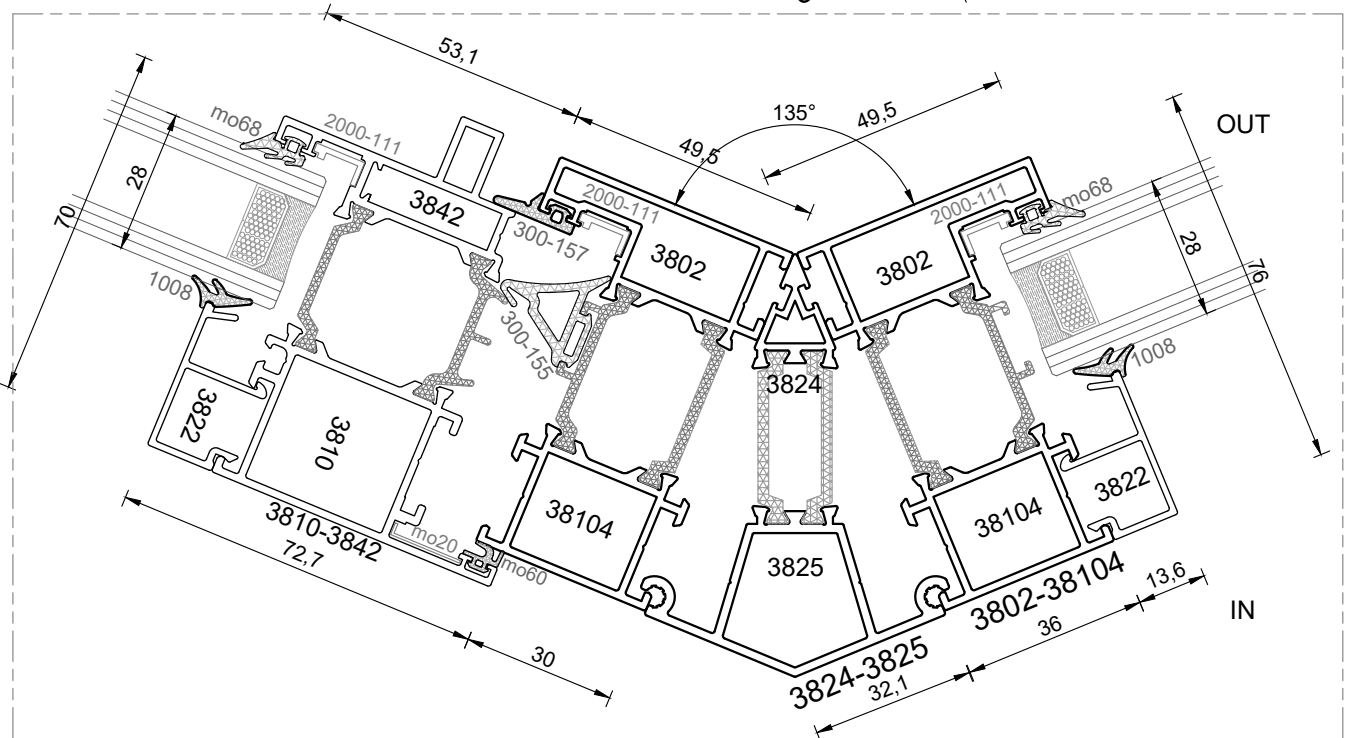
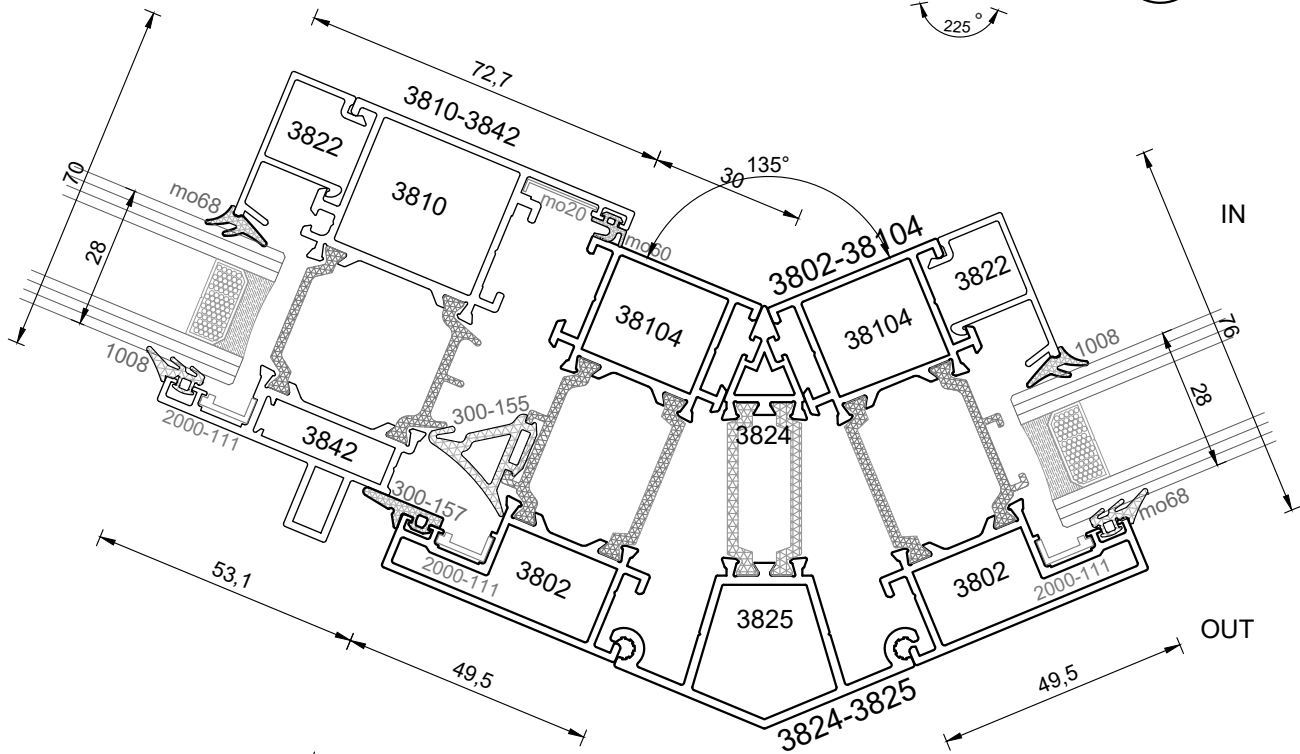
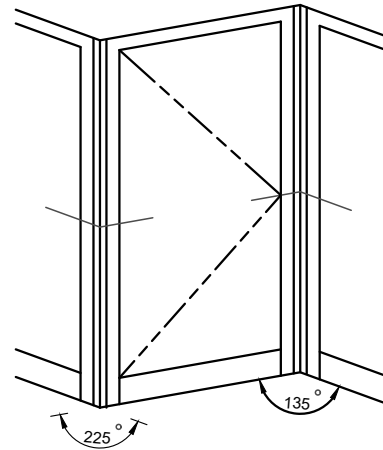

- CS59
- CS68
- CS68F
- CS68H
- CS77
- CS77H
- MASTERLINE8
- SLIMLINE38
- S560
- S560 Mono
- S560 Threshold

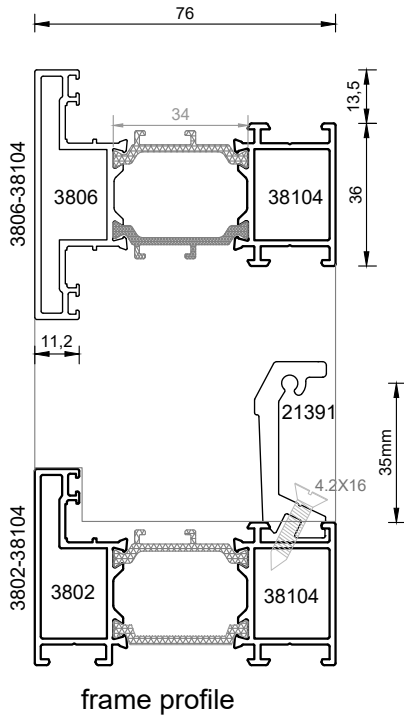

frame profile

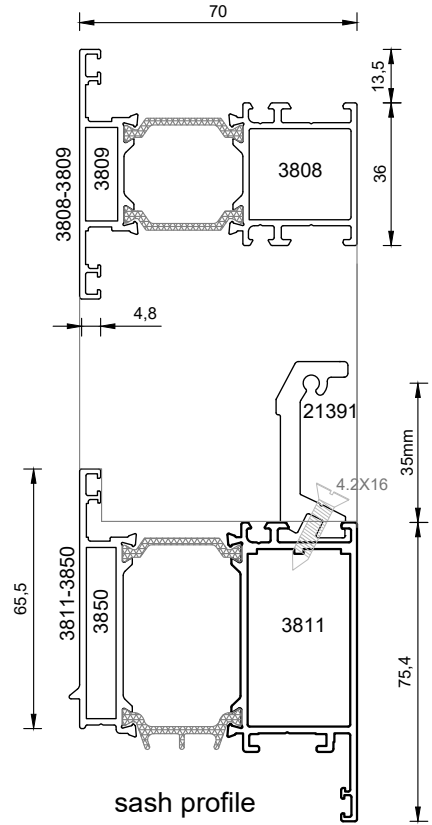

sash profile

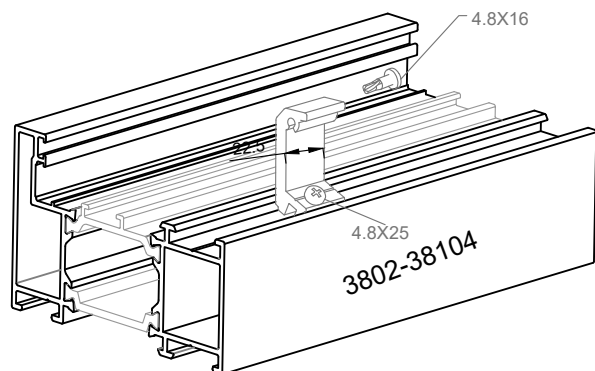
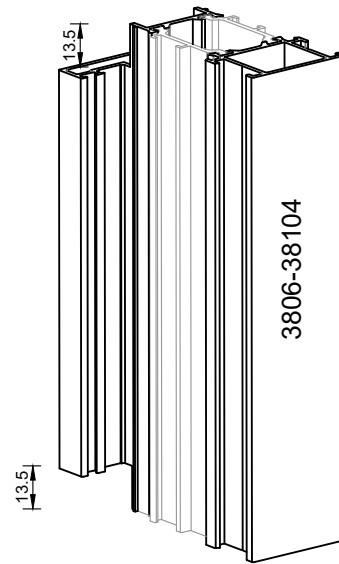
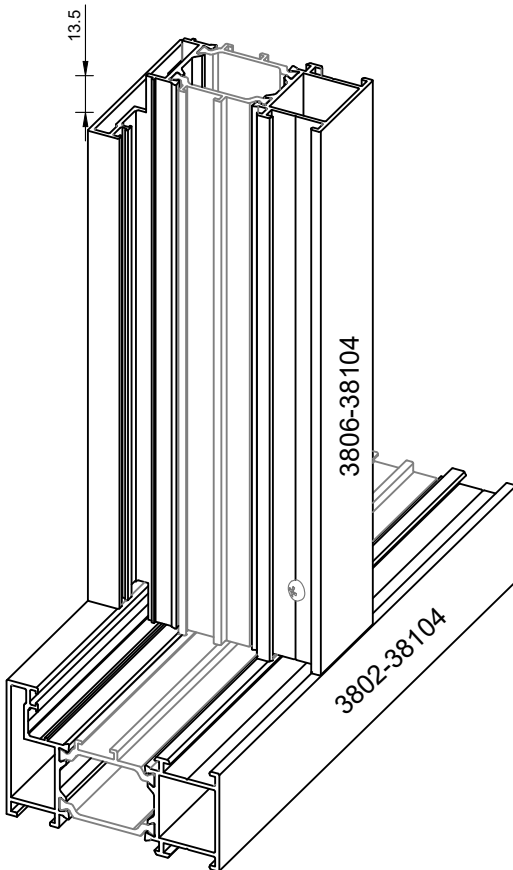

CS59

CS68

CS68F

CS68H

CS7

CS7H

MASTERLINE8

SLIMLINE38

S560

S560 Mono

S560 Threshold

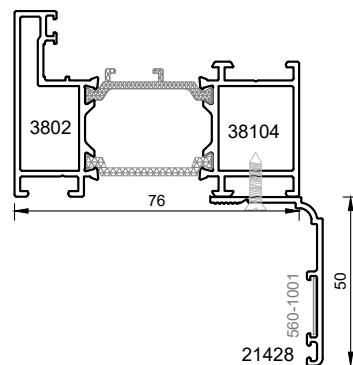
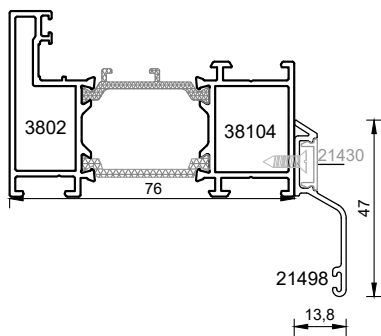
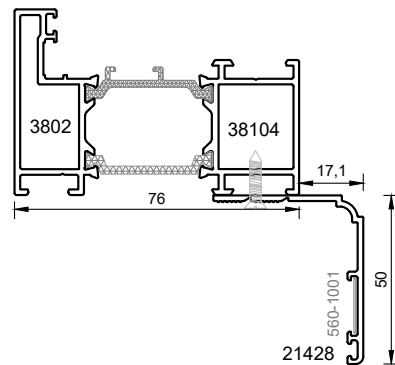
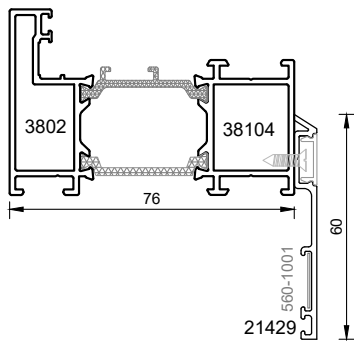
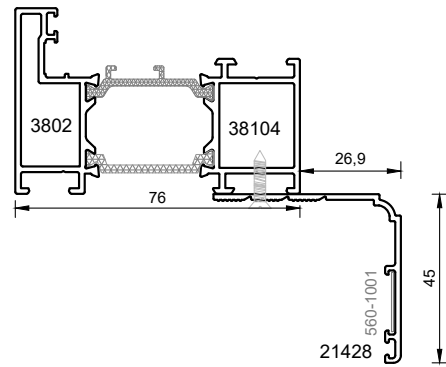
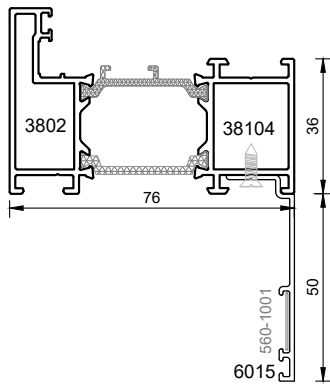
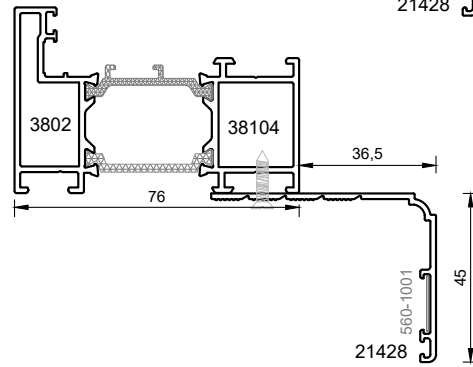
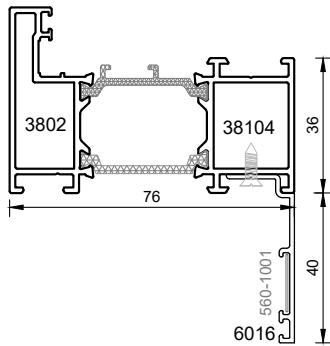
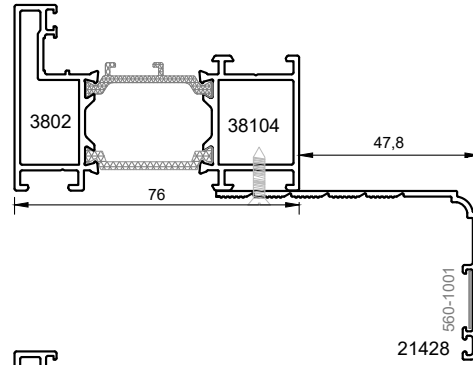
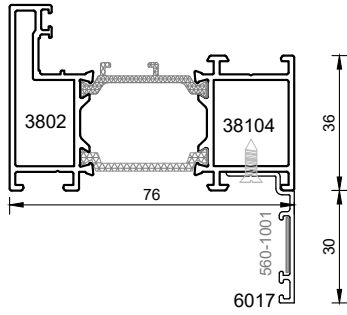

- CS59
- CS68
- CS68F
- CS68H
- CS77
- CS77H
- MASTERLINE8
- SLIMLINE38
- S560
- S560 Mono
- S560 Threshold

CS59

CS68

CS68F

CS68H

CS77

CS77H

MASTERLINE8

SLIMLINE38

S560

S560 Mono

S560 Threshold

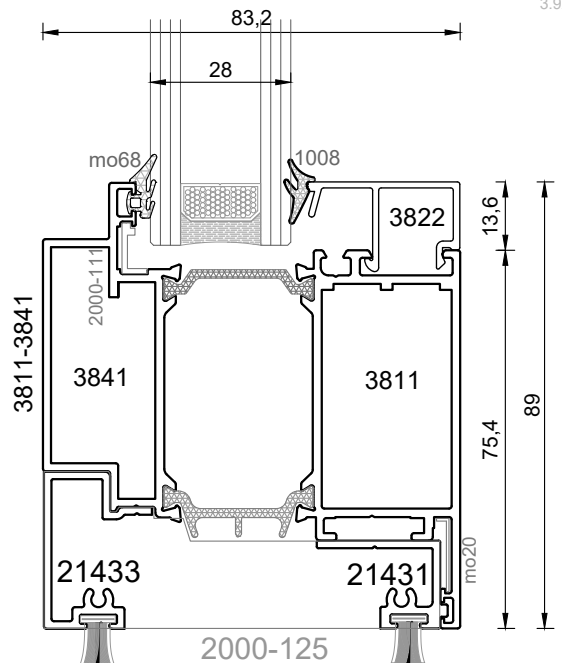
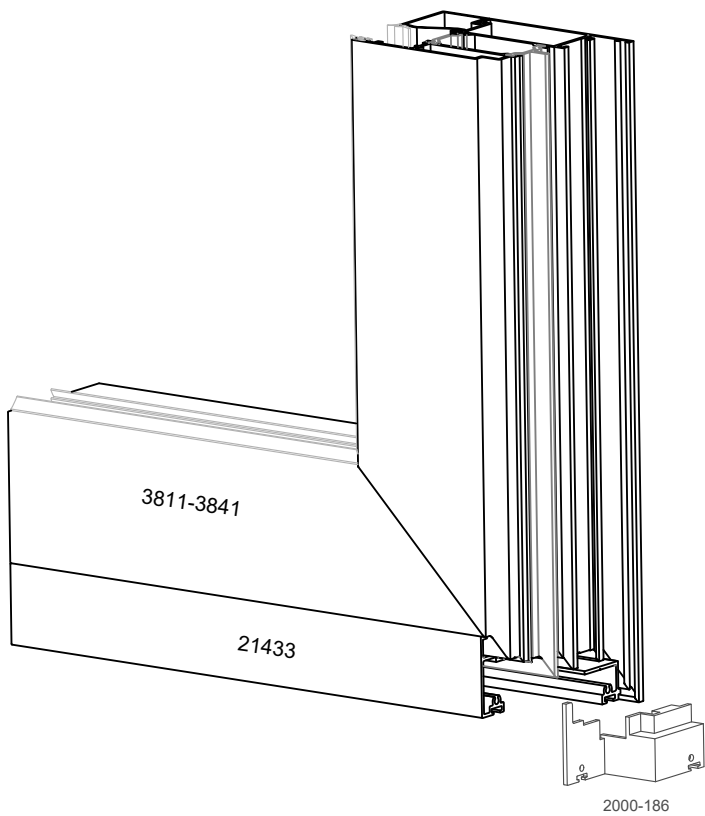
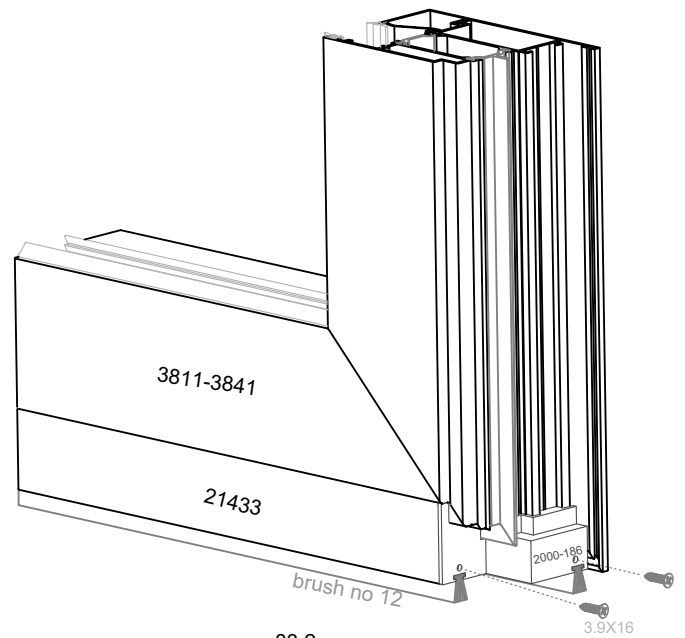
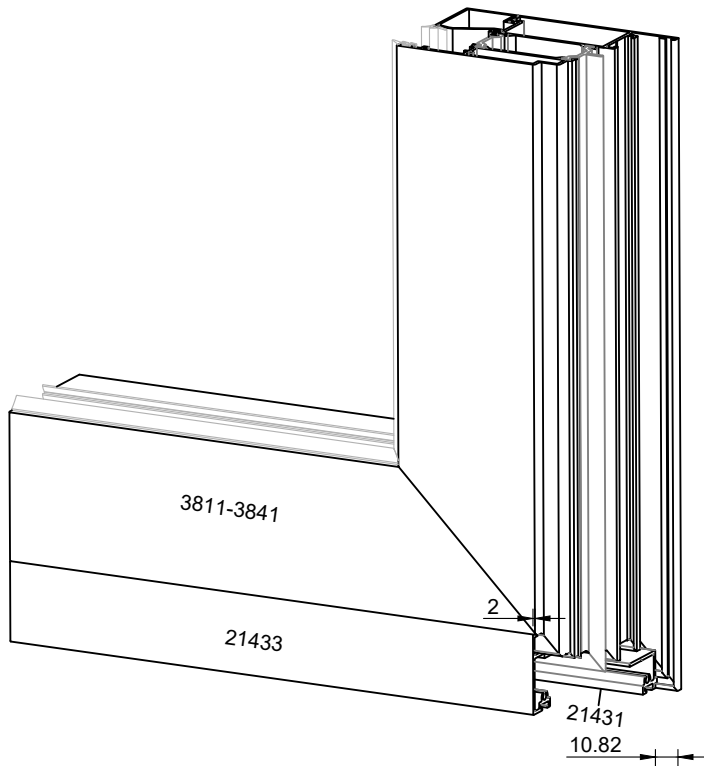

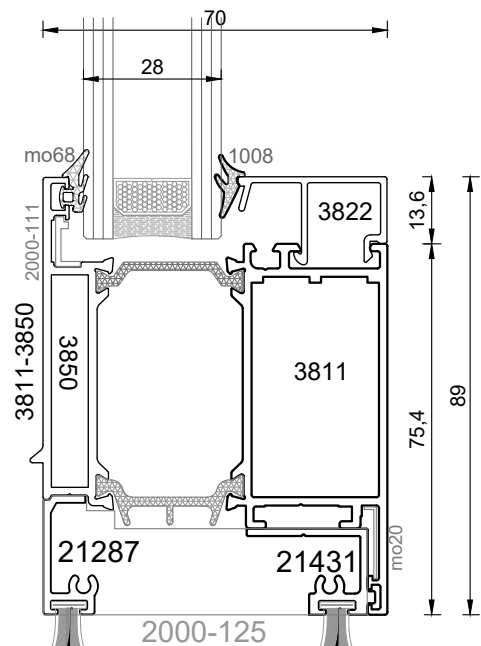
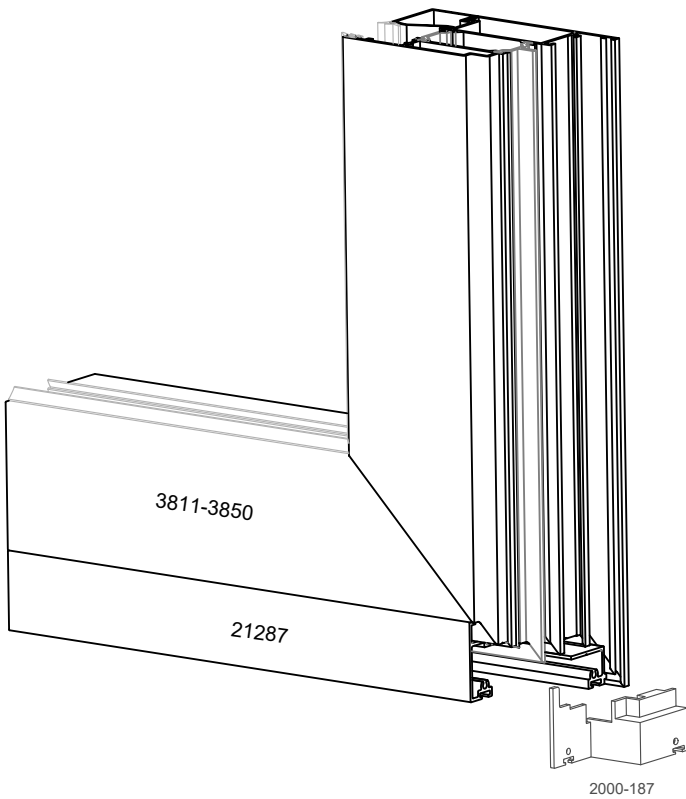
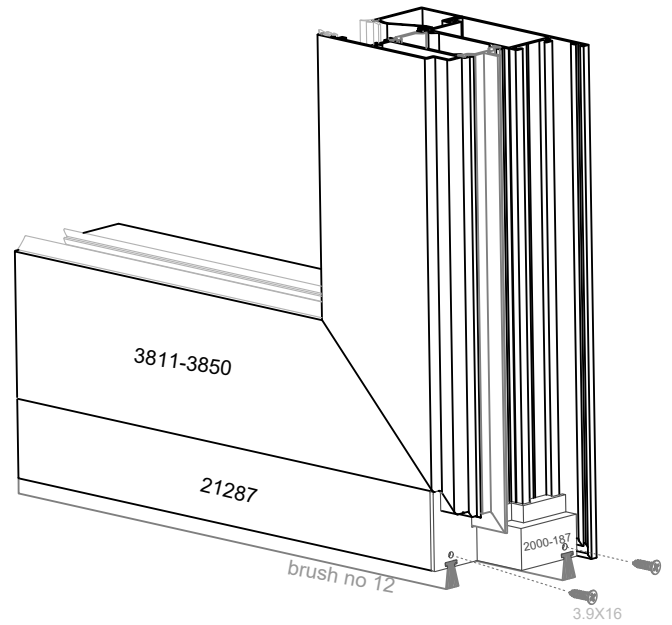
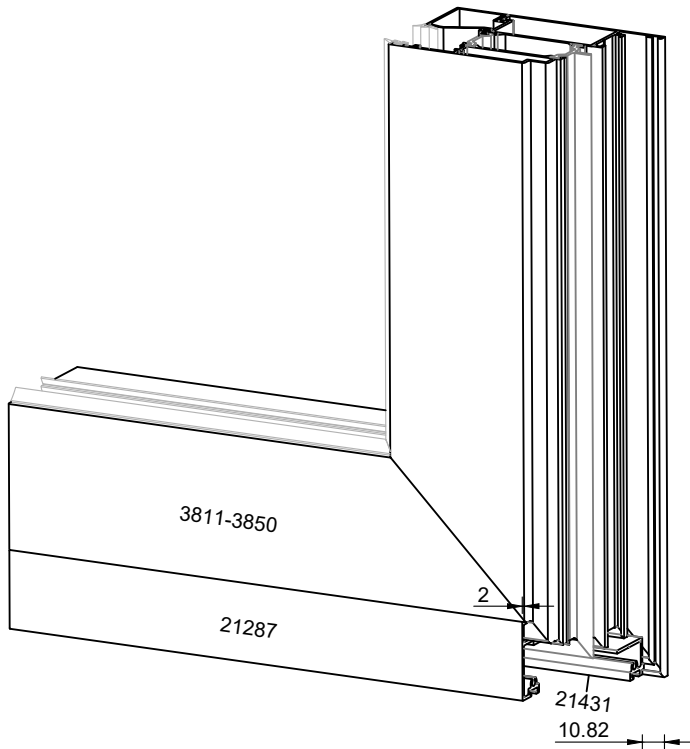

- CS59
- CS68
- CS68F
- CS68H
- CS77
- CS77H
- MASTERLINE8
- SLIMLINE38
- S560
- S560 Mono
- S560 Threshold